

# Application Note & Protocol Guide: Microwave-Assisted Synthesis Involving 4-Bromo-1,3-indandione

**Author:** BenchChem Technical Support Team. **Date:** April 2026

## Compound of Interest

Compound Name:	4-bromo-2,3-dihydro-1H-indene-1,3-dione
CAS No.:	15255-31-9
Cat. No.:	B6268530

[Get Quote](#)

## Abstract

This guide provides a comprehensive overview and detailed protocols for leveraging microwave-assisted organic synthesis (MAOS) in reactions involving 4-bromo-1,3-indandione. The indane-1,3-dione scaffold is a privileged structure in medicinal chemistry and materials science, serving as a versatile building block for a range of complex molecules.[1][2] The presence of a bromine atom at the 4-position offers a reactive handle for sophisticated molecular diversification, primarily through palladium-catalyzed cross-coupling reactions.[3] Microwave irradiation provides a powerful tool for accelerating these transformations, dramatically reducing reaction times from hours to minutes, improving yields, and often leading to cleaner reaction profiles.[4][5][6] This document details field-proven protocols for Suzuki-Miyaura C-C and Buchwald-Hartwig C-N cross-coupling reactions, discusses critical optimization parameters, and explains the fundamental principles that make MAOS an indispensable technology for modern drug discovery and development.

# Introduction: The Synergy of a Versatile Scaffold and an Enabling Technology

## 1.1. The 4-Bromo-1,3-indandione Building Block

Indane-1,3-dione and its derivatives are of significant interest due to their wide-ranging biological activities and applications as precursors in organic synthesis.[2][7] The core structure features an active methylene group flanked by two carbonyls, making it an excellent component for Knoevenagel condensations and the synthesis of various heterocyclic systems. [1] The introduction of a bromine atom onto the aromatic ring, as in 4-bromo-1,3-indandione, transforms it into a powerful intermediate for creating carbon-carbon and carbon-heteroatom bonds through transition-metal-catalyzed cross-coupling reactions.[3] This functional handle is key to building molecular complexity and exploring structure-activity relationships in drug discovery programs.

## 1.2. Microwave-Assisted Organic Synthesis (MAOS): A Paradigm Shift in Reaction Efficiency

Conventional synthetic methods often rely on slow, inefficient conductive heating from an external source.[6] Microwave-assisted synthesis represents a more sustainable and efficient alternative, utilizing microwave irradiation to heat the reaction mixture directly and selectively. [8] This is achieved through two primary mechanisms: dipolar polarization and ionic conduction. The result is rapid, uniform heating that can significantly accelerate reaction rates, often by orders of magnitude.[4][8] Key benefits of MAOS include:

- **Dramatically Reduced Reaction Times:** Reactions that take hours or days can often be completed in minutes.[9]
- **Improved Product Yields:** Rapid heating minimizes the formation of decomposition byproducts.[8]
- **Enhanced Reaction Selectivity:** Uniform heating reduces thermal gradients and potential side reactions.
- **Access to Higher Temperatures:** Sealed-vessel microwave reactors can safely reach temperatures and pressures far exceeding the atmospheric boiling point of the solvent, enabling difficult transformations.

This guide focuses on applying these advantages to the chemical modification of 4-bromo-1,3-indandione, providing researchers with robust protocols to accelerate their synthetic workflows.

## Core Application: Palladium-Catalyzed Cross-Coupling Reactions

The bromine atom on the 4-bromo-1,3-indandione scaffold is ideally suited for palladium-catalyzed cross-coupling reactions, which are foundational for modern medicinal chemistry. Microwave irradiation has proven to be exceptionally effective at accelerating these transformations.[\[5\]](#)

### Suzuki-Miyaura Cross-Coupling for C-C Bond Formation

The Suzuki-Miyaura reaction is one of the most versatile methods for constructing biaryl structures, which are common motifs in pharmaceutical agents. The reaction couples an organohalide with an organoboron compound, is tolerant of a wide range of functional groups, and uses reagents that are generally stable and non-toxic.

- **Catalyst:** Palladium catalysts, such as  $\text{Pd}(\text{PPh}_3)_4$  or pre-catalysts like XPhosPdG2, are essential for the catalytic cycle. The choice of catalyst and ligands can influence reaction efficiency, especially with challenging substrates.[\[10\]](#)
- **Base:** An inorganic base (e.g.,  $\text{K}_2\text{CO}_3$ ,  $\text{Cs}_2\text{CO}_3$ ) is required to activate the boronic acid. The cation of the base can influence the reaction rate, with cesium carbonate often providing faster kinetics.[\[11\]](#)
- **Solvent System:** A solvent mixture, typically an alcohol/water or dioxane/water system, is used to dissolve both the polar inorganic base and the less polar organic reactants. Water is an excellent solvent for microwave synthesis due to its high dielectric loss factor.[\[12\]](#)
- **Microwave Parameters:** Temperature is the most critical parameter. Temperatures between 100-140°C are common for Suzuki couplings.[\[9\]](#) Microwave irradiation allows for precise and rapid heating to the target temperature, ensuring the reaction proceeds efficiently.
- **Reagent Preparation:** To a 10 mL microwave reaction vial equipped with a Teflon-coated magnetic stir bar, add:

- 4-Bromo-1,3-indandione (e.g., 225 mg, 1.0 mmol)
- Arylboronic acid (1.2-1.5 equivalents, e.g., 1.2-1.5 mmol)
- Palladium catalyst (e.g., Pd(PPh<sub>3</sub>)<sub>4</sub>, 2-5 mol%)
- Base (e.g., Cs<sub>2</sub>CO<sub>3</sub>, 2.0 equivalents, 2.0 mmol)
- Solvent Addition: Add the chosen solvent system (e.g., 4-6 mL of Ethanol:Water, 4:1 v/v).
- Vial Sealing: Securely cap the vial using a specialized crimper. Ensure the seal is tight to contain pressure buildup.
- Microwave Irradiation: Place the vial into the cavity of a monomode microwave reactor.<sup>[13]</sup>  
Set the following parameters:
  - Temperature: 120 °C (Use ramp-to-temperature setting)
  - Time: 20 minutes
  - Power: Set to variable power to maintain the target temperature (e.g., max 200 W)
  - Stirring: On
- Reaction Work-up: After the reaction is complete and the vial has cooled to a safe temperature (<50 °C), carefully uncap it.
  - Dilute the reaction mixture with water (20 mL) and ethyl acetate (20 mL).
  - Transfer to a separatory funnel, separate the layers, and extract the aqueous layer with additional ethyl acetate (2 x 15 mL).
  - Combine the organic layers, wash with brine, dry over anhydrous Na<sub>2</sub>SO<sub>4</sub>, filter, and concentrate under reduced pressure.
- Purification: Purify the crude product via flash column chromatography on silica gel to obtain the desired 4-aryl-1,3-indandione derivative.

- **Low Conversion:** If starting material remains, consider increasing the reaction temperature (e.g., to 140 °C), extending the reaction time (e.g., to 30-40 minutes), or using a more active catalyst system.[10]
- **Decomposition:** The 1,3-dione moiety can be sensitive. If significant byproduct formation is observed, a lower temperature with simultaneous cooling may improve purity.[14] In some cases, enolization of the dione can interfere with the palladium catalyst; protecting the ketone as a 2,2-dimethoxy ketal prior to coupling can be an effective strategy for complex syntheses.[15]

Arylboric Acid	Catalyst (mol%)	Base (equiv.)	Solvent	Temp (°C)	Time (min)	Typical Yield Range
Phenylboronic acid	Pd(PPh <sub>3</sub> ) <sub>4</sub> (4)	Cs <sub>2</sub> CO <sub>3</sub> (2)	EtOH/H <sub>2</sub> O	120	20	85-95%
4-Methoxyphenylboronic acid	PdCl <sub>2</sub> (dppf) (3)	K <sub>2</sub> CO <sub>3</sub> (2.5)	Dioxane/H <sub>2</sub> O	130	15	80-90%
Thiophene-3-boronic acid	XPhosPdG 2 (2)	K <sub>3</sub> PO <sub>4</sub> (3)	t-BuOH/H <sub>2</sub> O	110	25	75-88%

## Buchwald-Hartwig Amination for C-N Bond Formation

The Buchwald-Hartwig amination is a powerful method for forming C-N bonds, enabling the synthesis of arylamines which are crucial structures in many pharmaceuticals. The reaction couples an aryl halide with an amine in the presence of a palladium catalyst.

- **Catalyst/Ligand System:** This reaction is highly dependent on the choice of a bulky, electron-rich phosphine ligand (e.g., XPhos, SPhos, RuPhos) coordinated to a palladium source (e.g., Pd<sub>2</sub>(dba)<sub>3</sub> or a pre-catalyst). The ligand facilitates both the oxidative addition and reductive elimination steps of the catalytic cycle.

- **Base:** A strong, non-nucleophilic base is required. Sodium tert-butoxide (NaOtBu) or lithium bis(trimethylsilyl)amide (LHMDS) are commonly used. The choice of base is critical and can significantly impact the reaction outcome.
- **Solvent:** Anhydrous, aprotic polar solvents like toluene, dioxane, or THF are necessary to ensure the stability of the catalyst and base.
- **Microwave Parameters:** Microwave heating accelerates the reaction, allowing for the use of less reactive amines or aryl chlorides. Temperatures typically range from 100-150 °C.
- **Reagent Preparation (Inert Atmosphere):** To a dry 10 mL microwave reaction vial containing a stir bar, add under an inert atmosphere (e.g., in a glovebox):
  - 4-Bromo-1,3-indandione (e.g., 225 mg, 1.0 mmol)
  - Palladium pre-catalyst (e.g., XPhos Pd G3, 1-3 mol%)
  - Base (e.g., NaOtBu, 1.4 equivalents, 1.4 mmol)
- **Reactant and Solvent Addition:** Add the amine (1.2 equivalents, 1.2 mmol) followed by anhydrous solvent (e.g., Toluene, 4-5 mL).
- **Vial Sealing and Irradiation:** Securely cap the vial, remove from the inert atmosphere, and place it in the microwave reactor.
  - Temperature: 130 °C
  - Time: 30 minutes
  - Power: Variable, to maintain temperature
  - Stirring: On
- **Reaction Work-up:** After cooling, quench the reaction by carefully adding saturated aqueous NH<sub>4</sub>Cl.
  - Extract the product with an organic solvent (e.g., ethyl acetate).

- Wash the combined organic layers with brine, dry over anhydrous  $\text{MgSO}_4$ , filter, and concentrate.
- Purification: Purify the crude product by flash column chromatography.

## Visualization of Workflows and Logic

Diagrams created with Graphviz help to visualize the experimental process and decision-making logic, enhancing clarity and reproducibility.

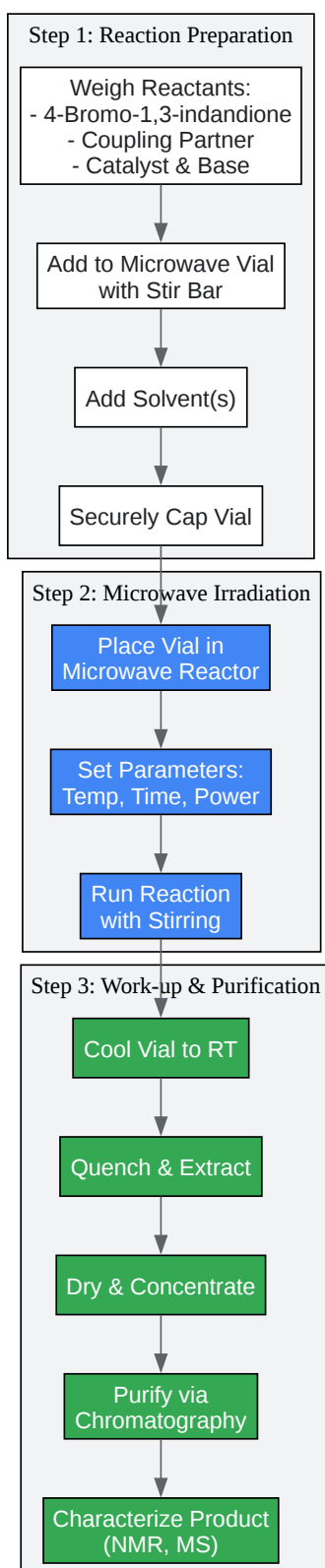

[Click to download full resolution via product page](#)

Caption: General workflow for microwave-assisted cross-coupling.

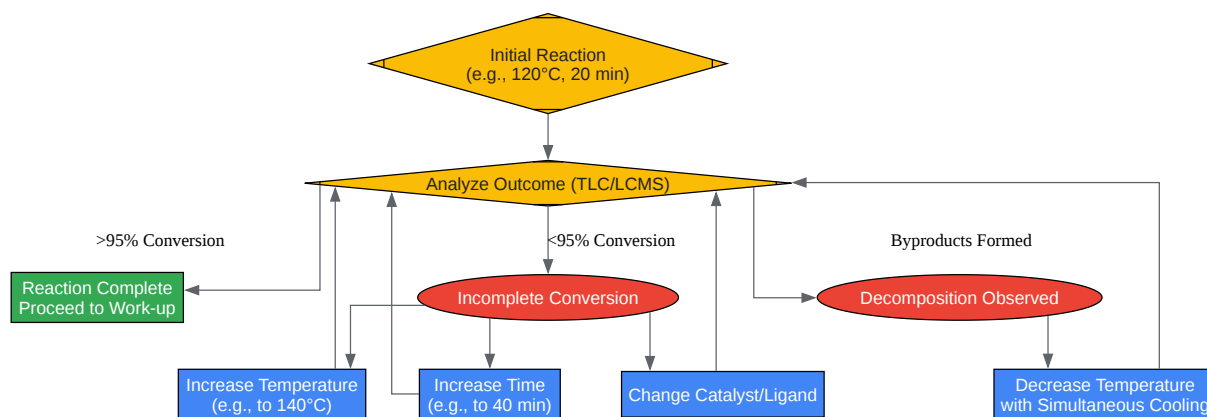

[Click to download full resolution via product page](#)

Caption: Logic diagram for reaction optimization.

## Safety Considerations

Working with microwave reactors requires adherence to specific safety protocols:

- **Pressure Monitoring:** Always use sealed vessels designed for microwave synthesis. Modern reactors are equipped with pressure sensors to prevent over-pressurization.[13]
- **Solvent Choice:** Be aware of the properties of your solvents. Highly volatile or non-polar solvents may not heat efficiently or could generate excessive pressure.
- **Stirring:** Always use a magnetic stir bar to prevent localized superheating and ensure even temperature distribution.

- **Vessel Integrity:** Inspect microwave vials for any cracks or defects before use. Never reuse disposable caps or septa.
- **Cooling:** Allow the reaction vessel to cool completely before opening to prevent sudden depressurization and solvent flashing.

## Conclusion

4-Bromo-1,3-indandione is a valuable and versatile starting material for the synthesis of novel compounds. When combined with the speed and efficiency of microwave-assisted synthesis, its utility is significantly enhanced. The protocols and principles outlined in this guide demonstrate how MAOS can be effectively applied to perform key transformations such as Suzuki-Miyaura and Buchwald-Hartwig cross-coupling reactions. By understanding the causality behind experimental choices and employing systematic optimization, researchers can rapidly generate diverse libraries of indandione derivatives, accelerating progress in drug discovery and materials science.

## References

- Unknown. (n.d.). Microwave-assisted optimization conditions for the synthesis of compound 3.
- BenchChem. (2025). Application Notes and Protocols for 4-Bromo-2,2-difluoro-3H-inden-1-one as a Synthetic Intermediate. Benchchem.
- Janczewski, Ł., Walczaka, M., Frączyka, J., Kamińska, Z. J., & Kolesińska, B. (2019). Microwave-assisted Cannizzaro reaction—Optimisation of reaction conditions. Figshare.
- Unknown. (2025). Microwave-Assisted Organic Synthesis: A Green Chemistry Strategy. International Journal of Research in Pharmacy and Allied Science.
- Baxendale Group. (2006). Microwave-Assisted Suzuki Coupling Reactions with an Encapsulated Palladium Catalyst for Batch and Continuous-Flow Transformation.
- cem.de. (n.d.). Open-Vessel Microwave-Promoted Suzuki Reactions Using Low Levels of Palladium Catalyst: Optimization and Scale-Up.
- Lirias. (2022). Microwave-Assisted Post-Ugi Reactions for the Synthesis of Polycycles.
- BenchChem. (2025). Application of 4-Bromo-3-oxo-N-phenylbutanamide in Drug Discovery: A Versatile Synthetic Intermediate. Benchchem.
- PMC. (n.d.). Efficient microwave-assisted Suzuki–Miyaura cross-coupling reaction of 3-bromo pyrazolo[1,5-a]pyrimidin-5(4H).
- ResearchGate. (2015). Synthetic studies of novel ninhydrin analogs.

- Salih, K. S. M., & Baqi, Y. (2020). Microwave-assisted palladium-catalyzed cross-coupling reactions: Generation of carbon–carbon bond. *Catalysts*, 10(1), 4.
- Salih, K. S. M., & Baqi, Y. (2019). Microwave-Assisted Palladium-Catalyzed Cross-Coupling Reactions: Generation of Carbon–Carbon Bond. MDPI.
- Unknown. (2022). CONVENTIONAL AND MICROWAVE-ASSISTED SYNTHESIS OF 4'-BROMOCHALCHONE UTILIZING 4-BROMOACETOPHENONE AND BENZALDEHYDE AS START. *Jurnal UNS*.
- Lamberts, J., & D'hooghe, M. (n.d.). Indane-1,3-Dione: From Synthetic Strategies to Applications. PMC.
- Unknown. (n.d.). Synthesis and microwave-promoted Suzuki-Miyaura cross-coupling reactions of 5-bromo-1,3,3-trimethyl-1,3-dihydro-6'H-spiro[indole-2,2'-piperidin]. *Lietuvos mokslų akademija*.
- Unknown. (2006). Microwave Chemistry: Cross-Couplings with Simultaneous Cooling, Newman-Kwart Rearrangement, N-Substituted Tetrahydroquinoline-diones.
- Unknown. (n.d.). Indandione and Its Derivatives - Chemical Compounds with High Biological Potential.
- Lamberts, J., & D'hooghe, M. (2025). Indane-1,3-Dione: From Synthetic Strategies to Applications. ResearchGate.

### Need Custom Synthesis?

BenchChem offers custom synthesis for rare earth carbides and specific isotopic labeling.

Email: [info@benchchem.com](mailto:info@benchchem.com) or [Request Quote Online](#).

## Sources

- 1. Indane-1,3-Dione: From Synthetic Strategies to Applications - PMC [[pmc.ncbi.nlm.nih.gov](https://pubmed.ncbi.nlm.nih.gov)]
- 2. [researchgate.net](https://www.researchgate.net) [[researchgate.net](https://www.researchgate.net)]
- 3. [pdf.benchchem.com](https://pdf.benchchem.com) [[pdf.benchchem.com](https://pdf.benchchem.com)]
- 4. [lirias.kuleuven.be](https://lirias.kuleuven.be) [[lirias.kuleuven.be](https://lirias.kuleuven.be)]
- 5. [squ.elsevierpure.com](https://squ.elsevierpure.com) [[squ.elsevierpure.com](https://squ.elsevierpure.com)]
- 6. [jurnal.uns.ac.id](https://jurnal.uns.ac.id) [[jurnal.uns.ac.id](https://jurnal.uns.ac.id)]
- 7. [eurekaselect.com](https://eurekaselect.com) [[eurekaselect.com](https://eurekaselect.com)]
- 8. [ijrpas.com](https://ijrpas.com) [[ijrpas.com](https://ijrpas.com)]

- [9. mdpi.com \[mdpi.com\]](#)
- [10. Efficient microwave-assisted Suzuki–Miyaura cross-coupling reaction of 3-bromo pyrazolo\[1,5-a\]pyrimidin-5\(4H\)-one: towards a new access to 3,5-diarylated 7-\(trifluoromethyl\)pyrazolo\[1,5-a\]pyrimidine derivatives - PMC \[pmc.ncbi.nlm.nih.gov\]](#)
- [11. mokslozurnalai.lmaleidykla.lt \[mokslozurnalai.lmaleidykla.lt\]](#)
- [12. cem.de \[cem.de\]](#)
- [13. tandf.figshare.com \[tandf.figshare.com\]](#)
- [14. Microwave Chemistry: Cross-Couplings with Simultaneous Cooling, Newman-Kwart Rearrangement, N-Substituted Tetrahydroquinoline-diones \[organic-chemistry.org\]](#)
- [15. researchgate.net \[researchgate.net\]](#)
- To cite this document: BenchChem. [Application Note & Protocol Guide: Microwave-Assisted Synthesis Involving 4-Bromo-1,3-indandione]. BenchChem, [2026]. [Online PDF]. Available at: [<https://www.benchchem.com/product/b6268530/docs#application-note-protocol-guide-microwave-assisted-synthesis-involving-4-bromo-1-3-indandione>]

---

### Disclaimer & Data Validity:

The information provided in this document is for Research Use Only (RUO) and is strictly not intended for diagnostic or therapeutic procedures. While BenchChem strives to provide accurate protocols, we make no warranties, express or implied, regarding the fitness of this product for every specific experimental setup.

**Technical Support:** The protocols provided are for reference purposes. Unsure if this reagent suits your experiment?

**Need Industrial/Bulk Grade?** [Request Custom Synthesis Quote](#)

## BenchChem

Our mission is to be the trusted global source of essential and advanced chemicals, empowering scientists and researchers to drive progress in science and industry.

### Contact

Address: 3281 E Guasti Rd  
Ontario, CA 91761, United States  
Phone: (601) 213-4426  
Email: [info@benchchem.com](mailto:info@benchchem.com)

Contact our Ph.D. Support Team for a compatibility check