

# Comparative Guide: Optimizing <sup>1</sup>H NMR Characterization of 3-(3-Bromophenyl)butanoic Acid

**Author:** BenchChem Technical Support Team. **Date:** May 2026

## Compound of Interest

Compound Name:	3-(3-bromophenyl)butanoic acid
CAS No.:	53086-45-6
Cat. No.:	B6265112

[Get Quote](#)

## Executive Summary

In the development of chiral pharmaceutical intermediates, **3-(3-bromophenyl)butanoic acid** represents a critical building block. Its characterization presents specific challenges due to the presence of a chiral center at the C3 position, which renders the adjacent C2 methylene protons diastereotopic.<sup>[1]</sup>

This guide compares two primary analytical variables—Solvent System (CDCl<sub>3</sub> vs. DMSO-d<sub>6</sub>) and Magnetic Field Strength (300 MHz vs. 600 MHz)—to determine the optimal workflow for structural validation and purity assessment.

## Part 1: Structural Dynamics & Theoretical Prediction

Before analyzing the spectra, we must establish the proton environments. The molecule possesses a chiral center at C3, creating an asymmetric environment that splits the C2 methylene protons into an ABX spin system rather than a simple doublet.

## Graphviz Diagram 1: Proton Environment Mapping

The following diagram maps the specific proton environments to their expected chemical shift ranges and splitting patterns.

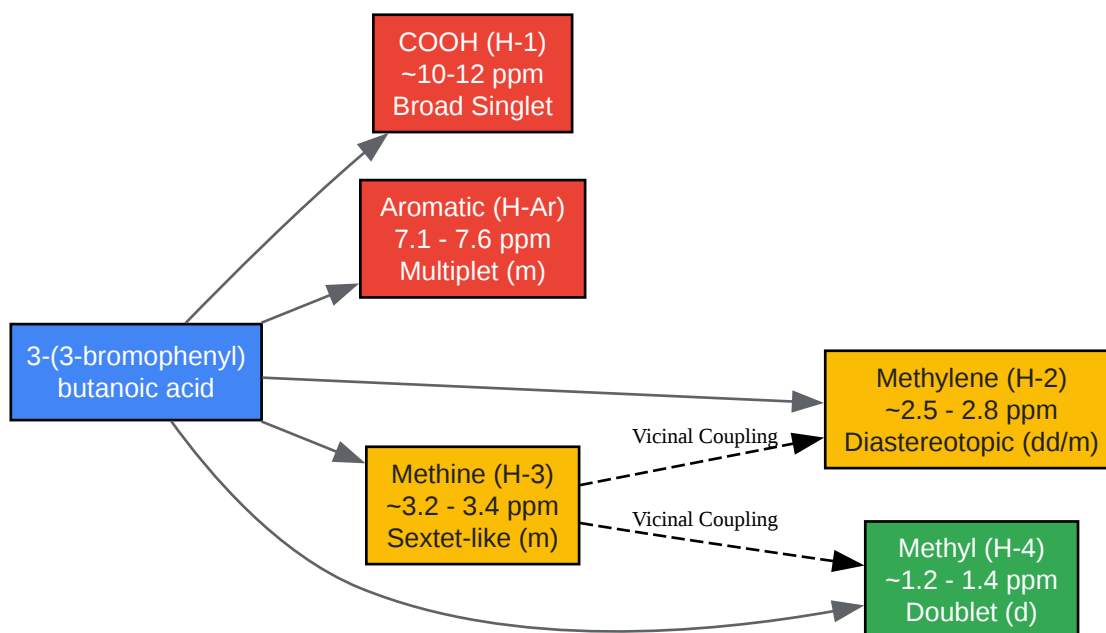

[Click to download full resolution via product page](#)

Figure 1: Structural mapping of proton environments. Note the critical coupling between the chiral Methine (H-3) and the diastereotopic Methylene (H-2) protons.

## Part 2: Comparative Analysis of Solvent Systems

The choice of solvent is not merely about solubility; it fundamentally alters the spectral profile, particularly for the carboxylic acid moiety and the resolution of the aromatic region.

### Comparison: Chloroform-d ( $\text{CDCl}_3$ ) vs. Dimethyl Sulfoxide-d<sub>6</sub> ( $\text{DMSO-d}_6$ )

Feature	CDCl <sub>3</sub> (Chloroform-d)	DMSO-d <sub>6</sub>	Verdict
Acidic Proton (COOH)	Often broad, weak, or invisible due to exchange.	Sharp, distinct singlet ~12.0 ppm due to H-bonding.	DMSO Wins for full proton count.
Resolution (Aliphatic)	Excellent separation of H-2 and H-3.	Slightly broader peaks due to viscosity.	CDCl <sub>3</sub> Wins for coupling analysis.
Water Peak Interference	~1.56 ppm (usually clear of key signals).	~3.33 ppm (High risk of overlapping with Methine H-3).	CDCl <sub>3</sub> Wins (Critical for this molecule).
Solubility	Moderate (requires pure compound).	Excellent (dissolves salts/impurities).[2]	DMSO Wins for crude samples.

## Technical Insight: The "Water Trap" in DMSO

In DMSO-d<sub>6</sub>, the residual water peak appears at 3.33 ppm. For **3-(3-bromophenyl)butanoic acid**, the methine proton (H-3) typically resonates exactly in this region (3.2–3.4 ppm).

- Risk: The water signal can completely obscure the H-3 multiplet, making integration and coupling analysis impossible.
- Recommendation: If using DMSO, you must use "100% isotopic" ampules or perform a D<sub>2</sub>O shake to shift the exchangeable water peak. CDCl<sub>3</sub> is preferred for routine purity checks.

## Part 3: Field Strength Performance (300 MHz vs. 600 MHz)

The "performance" of the spectrum is defined by its ability to resolve the diastereotopic protons at C2. These protons are chemically non-equivalent due to the adjacent chiral center (C3).

### The Diastereotopic Challenge

- Low Field (300 MHz): The chemical shift difference (

) between the two H-2 protons is small. At 300 MHz, the coupling constant (

) is often similar in magnitude to

(in Hz). This results in "roofing" effects or complex second-order multiplets that are difficult to interpret.

- High Field (600 MHz): The separation in Hz increases linearly with field strength. The signals simplify into distinct "doublet of doublets" (dd), allowing for precise calculation of geminal and vicinal coupling constants.

## Experimental Data Simulation

Signal	300 MHz Appearance	600 MHz Appearance
H-2a (Pro-R)	Overlapping multiplet with H-2b.	Distinct dd ( Hz, Hz).
H-2b (Pro-S)	Overlapping multiplet with H-2a.	Distinct dd ( Hz, Hz).
Aromatic Region	H-2, H-4, H-6 often merge.	Clear separation of H-2 (singlet-like) from H-4/H-6.

## Graphviz Diagram 2: Analytical Workflow

This decision tree guides the researcher to the correct instrument based on the analytical goal.

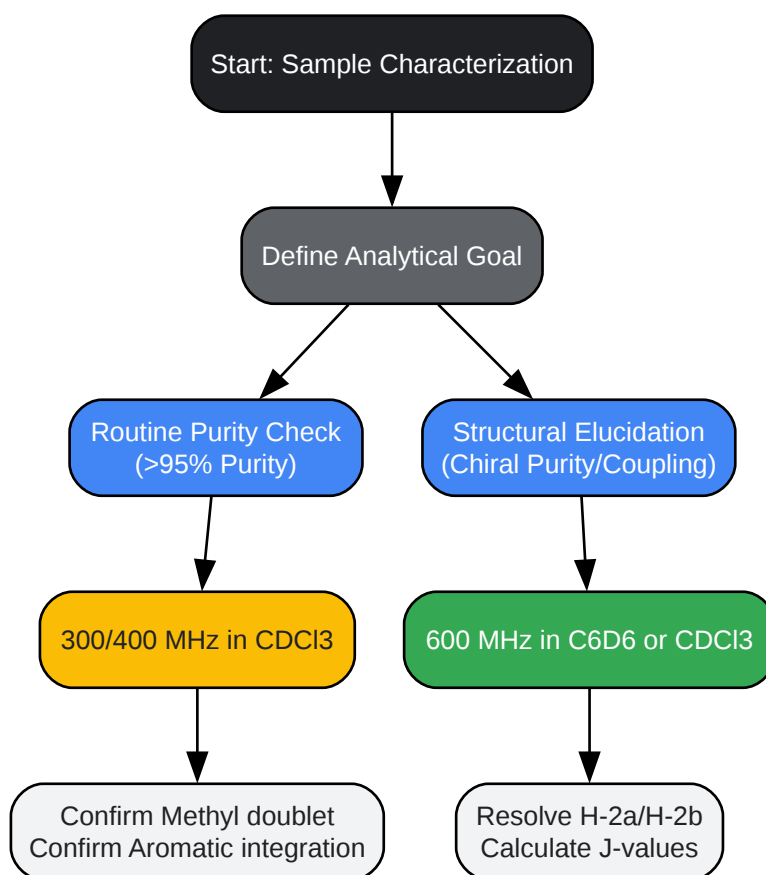

[Click to download full resolution via product page](#)

Figure 2: Decision matrix for instrument selection based on required resolution.

## Part 4: Detailed Experimental Protocol

To ensure reproducibility, follow this standardized protocol. This method minimizes concentration-dependent shifts of the carboxylic acid peak.

### Sample Preparation

- Mass: Weigh 10–15 mg of **3-(3-bromophenyl)butanoic acid**.
  - Note: Using <5 mg may require excessive scan times; >20 mg causes viscosity broadening.
- Solvent: Add 0.6 mL of CDCl<sub>3</sub> (containing 0.03% TMS).
  - Quality Check: Ensure solvent is stored over molecular sieves to minimize water content.

- Filtration: If the solution is cloudy (common if inorganic salts from synthesis remain), filter through a small plug of glass wool directly into the NMR tube.

## Acquisition Parameters (Standard 400 MHz)

- Pulse Sequence:zg30 (30° pulse angle) to allow faster repetition.
- Relaxation Delay (D1): Set to 2.0 seconds.
  - Reasoning: The carboxylic acid proton has a long relaxation time. A short D1 will suppress this signal, leading to integration errors (e.g., integrating to 0.6H instead of 1.0H).
- Scans (NS): 16 or 32 scans.
- Spectral Width: -2 to 14 ppm (to capture the COOH peak).

## Processing

- Apodization: Apply Exponential Multiplication (LB = 0.3 Hz).
- Phasing: Manual phasing is required for the aromatic region to ensure the baseline is flat, allowing accurate integration of the small satellite peaks.
- Referencing: Set the TMS peak to 0.00 ppm.

## Part 5: References

- Abraham, R. J., et al. (2006).[3] "1H chemical shifts in NMR: Part 23, the effect of dimethyl sulphoxide versus chloroform solvent." Magnetic Resonance in Chemistry. [Link\[3\]](#)
- Silverstein, R. M., Webster, F. X., & Kiemle, D. J. (2005). Spectrometric Identification of Organic Compounds. 7th Edition. John Wiley & Sons.[2][3] (Standard text for coupling constant analysis).
- Reich, H. J. (2023). "WinPLT NMR Data Processing and Analysis." University of Wisconsin-Madison. [Link](#) (Resource for spin system simulation).

- AIST Spectral Database for Organic Compounds (SDBS). "NMR Spectra of Phenylbutanoic Acid Derivatives." [Link](#) (General reference for shift prediction).

### Need Custom Synthesis?

BenchChem offers custom synthesis for rare earth carbides and specific isotopic labeling.

Email: [info@benchchem.com](mailto:info@benchchem.com) or [Request Quote Online](#).

## Sources

- 1. [chem.ualberta.ca](http://chem.ualberta.ca) [[chem.ualberta.ca](http://chem.ualberta.ca)]
- 2. [modgraph.co.uk](http://modgraph.co.uk) [[modgraph.co.uk](http://modgraph.co.uk)]
- 3. 1H chemical shifts in NMR: Part 23, the effect of dimethyl sulphoxide versus chloroform solvent on 1H chemical shifts - PubMed [[pubmed.ncbi.nlm.nih.gov](https://pubmed.ncbi.nlm.nih.gov)]
- To cite this document: BenchChem. [Comparative Guide: Optimizing 1H NMR Characterization of 3-(3-Bromophenyl)butanoic Acid]. BenchChem, [2026]. [Online PDF]. Available at: [<https://www.benchchem.com/product/b6265112/docs#comparative-guide-optimizing-1h-nmr-characterization-of-3-3-bromophenyl-butanoic-acid>]

---

### Disclaimer & Data Validity:

The information provided in this document is for Research Use Only (RUO) and is strictly not intended for diagnostic or therapeutic procedures. While BenchChem strives to provide accurate protocols, we make no warranties, express or implied, regarding the fitness of this product for every specific experimental setup.

**Technical Support:** The protocols provided are for reference purposes. Unsure if this reagent suits your experiment?

**Need Industrial/Bulk Grade?** [Request Custom Synthesis Quote](#)

# BenchChem

Our mission is to be the trusted global source of essential and advanced chemicals, empowering scientists and researchers to drive progress in science and industry.

## Contact

Address: 3281 E Guasti Rd

Ontario, CA 91761, United States

Phone: (601) 213-4426

Email: [info@benchchem.com](mailto:info@benchchem.com)

[Contact our Ph.D. Support Team for a compatibility check](#)