

Mass spectrometry fragmentation patterns of Boc-glutamic acid

Author: BenchChem Technical Support Team. **Date:** April 2026

Compound of Interest

Compound Name:	2- <i>[[tert-butoxy)carbonyl]amino}pentanedioic acid</i>
CAS No.:	120341-33-5
Cat. No.:	B6264968

[Get Quote](#)

An In-Depth Guide to the Mass Spectrometry Fragmentation of Boc-Glutamic Acid for Researchers and Drug Development Professionals

Introduction: Beyond Synthesis, Into Characterization

In the realms of peptide synthesis, medicinal chemistry, and drug development, N-Boc-L-glutamic acid (Boc-Glu) is an indispensable building block. The tert-butyloxycarbonyl (Boc) protecting group offers robust protection of the α -amino group, yet allows for facile deprotection under acidic conditions[1]. While its synthetic utility is well-documented, a comprehensive understanding of its behavior under mass spectrometric analysis is paramount for confident reaction monitoring, impurity profiling, and ultimate structural verification. The fragmentation pattern of a molecule is its unique fingerprint, providing irrefutable evidence of its identity.

This guide provides an in-depth analysis of the characteristic fragmentation patterns of Boc-glutamic acid, observed primarily through electrospray ionization tandem mass spectrometry

(ESI-MS/MS). We will dissect the fragmentation of the Boc group and the glutamic acid core, present the expected product ions, and provide a validated experimental protocol for acquiring high-quality spectral data. This document is designed for researchers, analytical scientists, and drug development professionals who rely on mass spectrometry for daily decision-making and require a deep, mechanistic understanding of their analytical data.

The Chemistry of Fragmentation: A Tale of Two Moieties

The fragmentation of protonated Boc-glutamic acid ($[M+H]^+$, m/z 248.12) in a collision cell is not random. It is a predictable cascade of bond cleavages dictated by the chemical properties of its constituent parts: the labile Boc protecting group and the glutamic acid backbone.

The Signature of the Boc Group

The Boc group is notoriously labile under the energetic conditions of collision-induced dissociation (CID). Its fragmentation is a cornerstone of identifying Boc-protected species. The primary pathways involve the tert-butyl moiety and the carbamate linkage.

- **Loss of Isobutylene (C_4H_8 , -56 Da):** The most common initial fragmentation is the neutral loss of isobutylene. This occurs via a six-membered ring transition state, resulting in a carbamic acid intermediate which is often unstable.
- **Sequential Loss of Carbon Dioxide (CO_2 , -44 Da):** Following the loss of isobutylene, the resulting carbamic acid readily decarboxylates, losing CO_2 .
- **Combined Loss of 100 Da:** Frequently, the losses of isobutylene and carbon dioxide occur in a concerted or rapid sequential manner within the collision cell, leading to a prominent neutral loss of 100 Da from the precursor ion[2].
- **Formation of the Tert-Butyl Cation ($C_4H_9^+$, m/z 57):** A highly characteristic and often abundant ion in the low-mass region is the tert-butyl cation. Its presence is a strong indicator of a Boc or other tert-butyl-containing group[3][4].
- **Loss of t-butanol ($C_4H_{10}O$, -74 Da):** In some cases, particularly in the context of certain peptide sequences, the loss of tert-butanol can also be observed[5].

Fragmentation of the Glutamic Acid Core

Once the Boc group is cleaved (resulting in protonated glutamic acid at m/z 148.06), or in higher-energy collisions, the glutamic acid backbone itself will fragment. These pathways are characteristic of the amino acid itself.

- Loss of Water (H_2O , -18 Da): Dehydration is a common fragmentation route for amino acids containing carboxyl groups, leading to the formation of a cyclic pyroglutamic acid derivative, especially when glutamic acid is at the N-terminus of a peptide[6][7].
- Sequential Loss of Carbon Monoxide (CO , -28 Da): Following the initial loss of water, a subsequent loss of carbon monoxide is often observed[8].
- Formation of the Immonium Ion (m/z 84.04): A hallmark of glutamic acid fragmentation is the formation of its corresponding immonium ion. This fragment is invaluable for confirming the amino acid's identity[9].

Visualizing the Fragmentation Cascade of Boc-Glutamic Acid

By combining our understanding of the two moieties, we can predict the complete MS/MS fragmentation pattern of protonated Boc-glutamic acid ($[M+H]^+$ at m/z 248.12).

Primary Fragmentation Pathway: The Boc Group Dissociation

The dominant fragmentation route involves the dissociation of the Boc protecting group, leading directly to the formation of protonated glutamic acid.

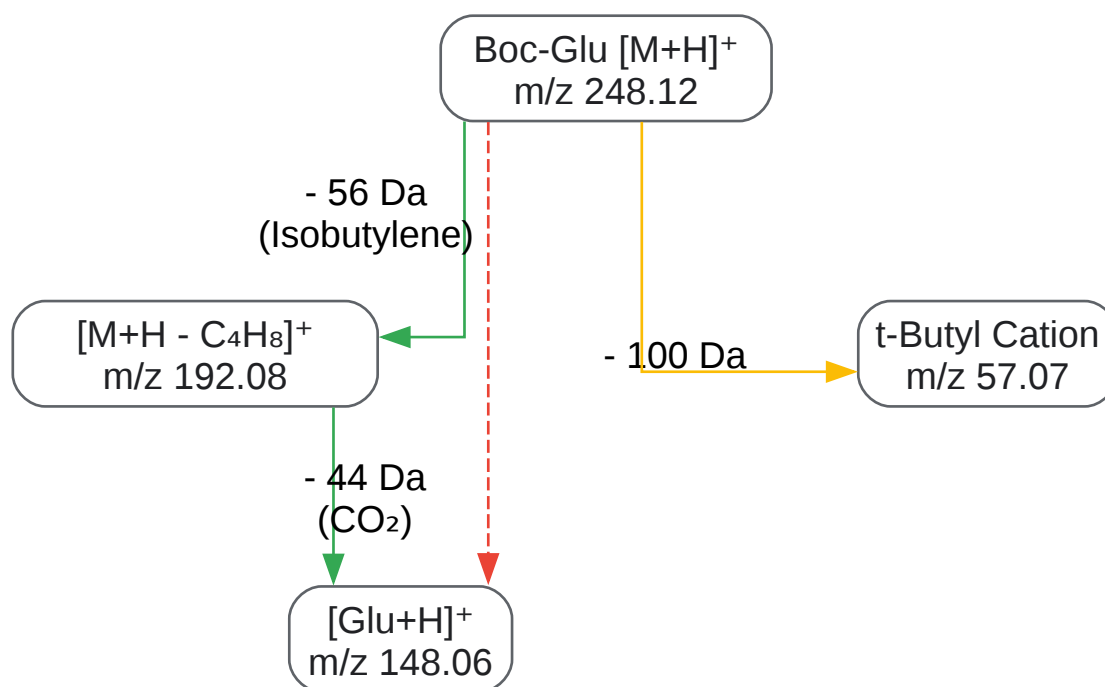

[Click to download full resolution via product page](#)

Caption: Primary fragmentation of Boc-glutamic acid via Boc group losses.

Secondary Fragmentation Pathway: Glutamic Acid Core Dissociation

The product ion at m/z 148.06 (protonated glutamic acid) can undergo further fragmentation to yield ions characteristic of the amino acid itself.

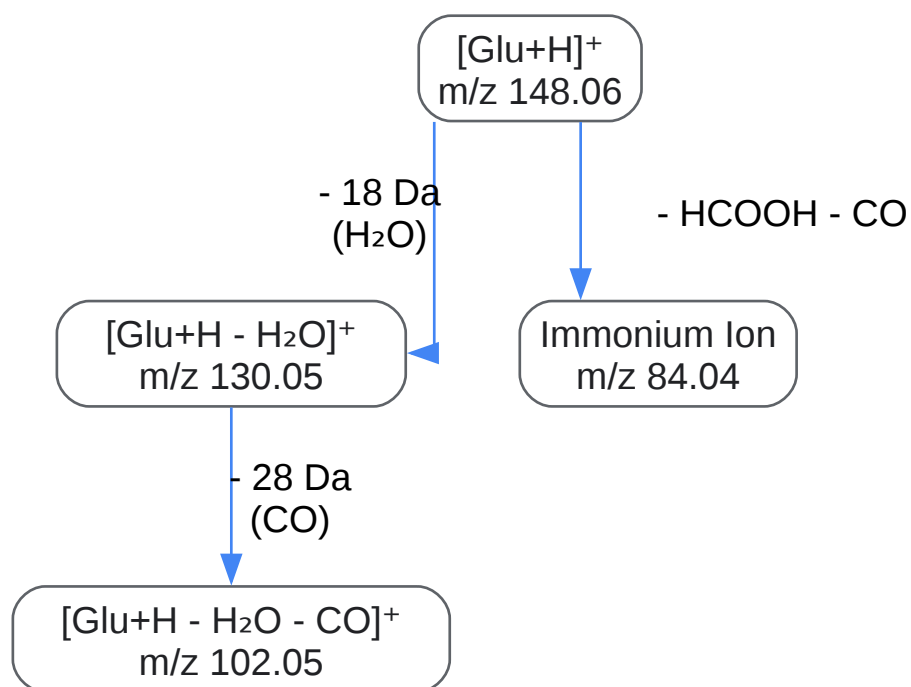

[Click to download full resolution via product page](#)

Caption: Secondary fragmentation of the resulting glutamic acid ion.

Summary of Key Fragment Ions

The following table summarizes the key ions expected in the ESI-MS/MS spectrum of Boc-glutamic acid.

Observed m/z	Proposed Fragment Identity / Neutral Loss	Pathway	Significance
248.12	[M+H] ⁺	-	Precursor Ion
230.11	[M+H - H ₂ O] ⁺	Glutamic Acid Core	Initial loss of water
192.08	[M+H - C ₄ H ₈] ⁺	Boc Group	Loss of isobutylene
148.06	[M+H - C ₄ H ₈ - CO ₂] ⁺ or [Glu+H] ⁺	Boc Group	Loss of Boc group (100 Da), forms protonated glutamic acid
130.05	[Glu+H - H ₂ O] ⁺	Glutamic Acid Core	Dehydration of glutamic acid
102.05	[Glu+H - H ₂ O - CO] ⁺	Glutamic Acid Core	Decarbonylation following dehydration
84.04	Immonium Ion	Glutamic Acid Core	Confirmatory ion for glutamic acid
57.07	[C ₄ H ₉] ⁺	Boc Group	Confirmatory ion for Boc group

Comparative Analysis: Distinguishing Similar Structures

In a research or development setting, it is often necessary to distinguish the target compound from structurally similar alternatives.

- **Boc-Glutamic Acid vs. Fmoc-Glutamic Acid:** The fragmentation of an Fmoc-protected amino acid is dominated by the cleavage of the Fmoc group, typically yielding a very strong signal at m/z 179, corresponding to the dibenzofulvene moiety. This provides a clear distinction from the Boc-group fragments (m/z 57, neutral loss of 56/100 Da).
- **Boc-Glutamic Acid vs. Boc-Glutamine:** While both would show identical Boc-group fragmentation, their core fragmentation would differ. Boc-glutamine's core fragmentation

would be characterized by the loss of ammonia (-17 Da) from its side-chain amide, a pathway not available to glutamic acid.

Experimental Protocol for High-Confidence MS/MS Analysis

This protocol outlines a self-validating methodology for obtaining a high-quality, reproducible MS/MS spectrum of Boc-glutamic acid using a standard UPLC-QTOF or Triple Quadrupole mass spectrometer.

1. Sample Preparation

- Objective: To prepare a sample solution suitable for ESI that minimizes in-source fragmentation.
- Protocol:
 - Prepare a 1 mg/mL stock solution of Boc-L-glutamic acid in methanol.
 - Dilute the stock solution to a final concentration of 1-10 µg/mL in a mobile phase-like solvent.
 - Recommended Solvent: 50:50 (v/v) acetonitrile:water with 0.1% formic acid.
- Causality: Formic acid is a sufficiently strong modifier to promote protonation for positive-ion ESI but is gentle enough to minimize the premature, in-source cleavage of the acid-labile Boc group. Trifluoroacetic acid (TFA) should be avoided as it can cause significant deprotection before the sample even enters the mass spectrometer[10].

2. Liquid Chromatography (Optional, for sample cleanup)

- Objective: To separate the analyte from salts or impurities.
- Protocol:
 - Use a C18 reversed-phase column (e.g., 2.1 mm x 50 mm, 1.8 µm).

- Employ a simple isocratic flow of 50:50 acetonitrile:water with 0.1% formic acid at a flow rate of 0.3 mL/min.
- If performing direct infusion, bypass the column and introduce the sample directly using a syringe pump at 5-10 μ L/min.

3. Mass Spectrometer Settings (Positive ESI Mode)

- Objective: To optimize ionization and select the precursor ion for fragmentation.
- Step 1: Full Scan (MS1) Analysis
 - Scan Range: m/z 50 - 500.
 - Capillary Voltage: 3.0 - 3.5 kV.
 - Source Temperature: 120-150 °C.
 - Desolvation Gas Flow/Temp: Optimize for instrument (e.g., 600 L/hr, 350 °C).
 - Rationale: First, confirm the presence of the protonated precursor ion, $[M+H]^+$, at m/z 248.12. This validates the starting point for MS/MS.
- Step 2: Tandem MS (MS/MS or Product Ion Scan) Analysis
 - Precursor Ion Selection: Isolate the ion at m/z 248.12.
 - Collision Gas: Argon.
 - Collision Energy (CE): Perform a collision energy ramp (e.g., 10-40 eV).
 - Rationale: A CE ramp is crucial for a comprehensive analysis. Low energies (10-15 eV) will favor the gentle fragmentation of the Boc group (loss of 56 and 100 Da). Higher energies (25-40 eV) will induce fragmentation of the glutamic acid core, ensuring the observation of the confirmatory immonium ion at m/z 84.04. This approach provides a complete fingerprint in a single run.

4. Data Interpretation

- Objective: To confirm the structure of Boc-glutamic acid.
- Protocol:
 - Examine the resulting MS/MS spectrum.
 - Confirm the presence of the key fragment ions outlined in the summary table above.
 - The simultaneous observation of the precursor at m/z 248.12, the tert-butyl cation at m/z 57.07, the neutral loss of 100 Da leading to m/z 148.06, and the glutamic acid immonium ion at m/z 84.04 provides unequivocal identification.

References

- Vrkic, I., et al. (2012). Protonation Sites and Dissociation Mechanisms of t-Butylcarbamates in Tandem Mass Spectrometric Assays for Newborn Screening. *Journal of the American Society for Mass Spectrometry*. Available at: [\[Link\]](#)
- Liu, C., et al. (2025). Mass Fragmentation Characteristics of t-Boc Substituted Drug Precursors. *Journal of Chinese Mass Spectrometry Society*, 46(1), 40-47. Available at: [\[Link\]](#)
- Reddy, P. N., et al. (2010). Differentiation of Boc-protected alpha,delta-/delta,alpha- and beta,delta-/delta,beta-hybrid peptide positional isomers by electrospray ionization tandem mass spectrometry. *Journal of Mass Spectrometry*, 45(6), 651-62. Available at: [\[Link\]](#)
- Reddy, P. N., et al. (2007). Positive and Negative Ion Electrospray Tandem Mass Spectrometry (ESI MS/MS) of Boc-protected Peptides Containing Repeats of L-Ala-gamma4Caa/gamma4Caa-L-Ala: Differentiation of Some Positional Isomeric Peptides. *Journal of the American Society for Mass Spectrometry*, 18(4), 651-62. Available at: [\[Link\]](#)
- Harrison, A. G., & Yalcin, T. (2005). Fragmentation pathway for glutamine identification. *Journal of the American Society for Mass Spectrometry*, 16(7), 1192-203. Available at: [\[Link\]](#)
- Mascot. (n.d.). Peptide fragmentation. Matrix Science. Available at: [\[Link\]](#)
- Paizs, B., & Suhai, S. (2005). Fragmentation pathway for glutamine identification: loss of 73 Da from dimethylformamidinium glutamine isobutyl ester. *Journal of the American Society for Mass Spectrometry*, 16(7), 1192-203. Available at: [\[Link\]](#)

- Tabb, D. L., et al. (2003). Fragmentation Characteristics of Collision-Induced Dissociation in MALDI TOF/TOF Mass Spectrometry. *Journal of Proteome Research*, 2(6), 647-59. Available at: [\[Link\]](#)
- Wu, Z., et al. (2019). Revisiting Fragmentation Reactions of Protonated α -Amino Acids by High-Resolution Electrospray Ionization Tandem Mass Spectrometry with Collision-Induced Dissociation. *Scientific Reports*, 9(1), 6453. Available at: [\[Link\]](#)
- Wu, Z., et al. (2019). Revisiting Fragmentation Reactions of Protonated α -Amino Acids by High-Resolution Electrospray Ionization Tandem Mass Spectrometry with. *Scientific Reports*, 9(1). Available at: [\[Link\]](#)
- Lioe, H., et al. (2010). Effect of N-terminal glutamic acid and glutamine on fragmentation of peptide ions. *Journal of the American Society for Mass Spectrometry*, 21(7), 1192-203. Available at: [\[Link\]](#)
- Schilling, M., et al. (2016). Figure 7. Identification of characteristic fragment ions. ResearchGate. Available at: [\[Link\]](#)
- LibreTexts. (2023). Mass Spectrometry - Fragmentation Patterns. Chemistry LibreTexts. Available at: [\[Link\]](#)
- Reddy, P. N., et al. (2008). Electrospray ionization tandem mass spectrometric study on the effect of N-terminal β - and γ -carbo amino acids on fragmentation of GABA-hybrid peptides. *Rapid Communications in Mass Spectrometry*, 22(21), 3421-31. Available at: [\[Link\]](#)
- Common Organic Chemistry. (n.d.). Boc Deprotection Mechanism - TFA. Common Organic Chemistry. Available at: [\[Link\]](#)
- Moser, A. (2026). Confirmation of Synthesis: using MS to identify a protective group. ACD/Labs. Available at: [\[Link\]](#)
- Lioe, H., et al. (2010). Effect of N-terminal glutamic acid and glutamine on fragmentation of peptide ions. *Journal of the American Society for Mass Spectrometry*, 21(7), 1192-203. Available at: [\[Link\]](#)

- Rose, K., et al. (1980). A mass-spectrometric method for the estimation of the ratio of gamma-carboxyglutamic acid to glutamic acid at specific sites in proteins. *Biochemical Journal*, 187(1), 239-43. Available at: [[Link](#)]
- Wysocki, V. H., et al. (2013). *1 Mass Spectrometry of Amino Acids and Proteins*. Wiley-VCH. Available at: [[Link](#)]
- Bugatti, K. (2021). How can I avoid the Boc-cleavage during Mass Analysis?. ResearchGate. Available at: [[Link](#)]
- Sparkman, O. D. (n.d.). CHAPTER 2 Fragmentation and Interpretation of Spectra. *Introduction to Mass Spectrometry*. Available at: [[Link](#)]

Need Custom Synthesis?

BenchChem offers custom synthesis for rare earth carbides and specific isotopic labeling.

Email: info@benchchem.com or [Request Quote Online](#).

Sources

1. [Boc Deprotection Mechanism - TFA \[commonorganicchemistry.com\]](#)
2. [Protonation Sites and Dissociation Mechanisms of t-Butylcarbamates in Tandem Mass Spectrometric Assays for Newborn Screening - PMC \[pmc.ncbi.nlm.nih.gov\]](#)
3. [Mass Fragmentation Characteristics of *t*-Boc Substituted Drug Precursors \[zpxb.xml-journal.net\]](#)
4. [acdlabs.com \[acdlabs.com\]](#)
5. [Differentiation of Boc-protected alpha,delta-/delta,alpha- and beta,delta-/delta,beta-hybrid peptide positional isomers by electrospray ionization tandem mass spectrometry - PubMed \[pubmed.ncbi.nlm.nih.gov\]](#)
6. [Effect of N-terminal glutamic acid and glutamine on fragmentation of peptide ions - PubMed \[pubmed.ncbi.nlm.nih.gov\]](#)
7. [Effect of N-terminal glutamic acid and glutamine on fragmentation of peptide ions - PubMed \[pubmed.ncbi.nlm.nih.gov\]](#)
8. [researchgate.net \[researchgate.net\]](#)

- [9. documents.thermofisher.com](https://documents.thermofisher.com) [documents.thermofisher.com]
- [10. researchgate.net](https://researchgate.net) [researchgate.net]
- To cite this document: BenchChem. [Mass spectrometry fragmentation patterns of Boc-glutamic acid]. BenchChem, [2026]. [Online PDF]. Available at: [<https://www.benchchem.com/product/b6264968/docs#mass-spectrometry-fragmentation-patterns-of-boc-glutamic-acid>]

Disclaimer & Data Validity:

The information provided in this document is for Research Use Only (RUO) and is strictly not intended for diagnostic or therapeutic procedures. While BenchChem strives to provide accurate protocols, we make no warranties, express or implied, regarding the fitness of this product for every specific experimental setup.

Technical Support: The protocols provided are for reference purposes. Unsure if this reagent suits your experiment?

Need Industrial/Bulk Grade? [Request Custom Synthesis Quote](#)

BenchChem

Our mission is to be the trusted global source of essential and advanced chemicals, empowering scientists and researchers to drive progress in science and industry.

Contact

Address: 3281 E Guasti Rd
Ontario, CA 91761, United States
Phone: (601) 213-4426
Email: info@benchchem.com

[Contact our Ph.D. Support Team for a compatibility check](#)