

# Application Note: Functionalization of 5-Iodo-1,3,4-Thiadiazoles

**Author:** BenchChem Technical Support Team. **Date:** April 2026

## Compound of Interest

Compound Name: 2-ETHYL-5-iodo-1,3,4-  
THIADIAZOLE

CAS No.: 1493270-39-5

Cat. No.: B6260384

[Get Quote](#)

## Executive Summary & Reactivity Profile

The 1,3,4-thiadiazole ring is an electron-deficient heteroaromatic system (

-excessive but electron-poor carbons due to N/S electronegativity). The C2 and C5 positions are highly susceptible to nucleophilic attack.<sup>[1]</sup> While the 5-iodo derivative is classically viewed as a substrate for Pd-catalyzed cross-couplings (Suzuki, Sonogashira), it serves as an excellent electrophile for

reactions due to the weak C-I bond and the inductive electron-withdrawal of the adjacent nitrogen atoms.

Key Reactivity Differentiators:

- **Leaving Group Ability:** In this specific heteroaromatic system, the order of reactivity for can be anomalous. While F  
Cl is standard for activated benzenes (due to the rate-determining addition step), the weak

C–I bond in thiadiazoles often facilitates rapid substitution, especially with soft nucleophiles (thiols) or under high-temperature conditions where bond cleavage becomes significant.

- Chemoselectivity: The 5-iodo position is more reactive than 5-bromo or 5-chloro analogs in metal-catalyzed manifolds but comparable or slightly less reactive in pure

addition-elimination regimes unless specific activation (e.g., acid catalysis) is employed.

- Stability Warning: The 1,3,4-thiadiazole ring is sensitive to strong aqueous bases (e.g., NaOH, KOH at high temp), which can cause ring-opening to hydrazine derivatives. Non-nucleophilic bases or anhydrous conditions are preferred.

## Reaction Pathways & Mechanism

The following diagram illustrates the synthesis of the 5-iodo precursor via the Sandmeyer reaction and its subsequent divergent reactivity.

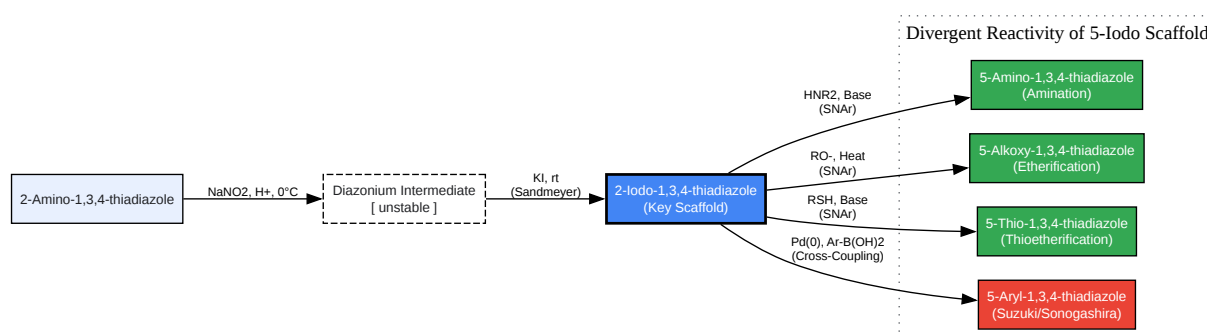

[Click to download full resolution via product page](#)

Figure 1: Synthetic workflow from the 2-amino precursor to diverse 5-substituted derivatives. The 5-iodo intermediate acts as a linchpin for both

(green nodes) and Pd-coupling (red node).

## Detailed Experimental Protocols

Rationale: Direct iodination of the ring is difficult. The Sandmeyer reaction from the commercially available amine is the standard robust route.

Protocol:

- Diazotization: Suspend 2-amino-5-substituted-1,3,4-thiadiazole (10 mmol) in acetonitrile (20 mL) and cool to 0°C.
- Acidification: Add p-toluenesulfonic acid (30 mmol) or aqueous slowly.
- Iodination: Add a solution of KI (20 mmol) and NaNO<sub>2</sub> (20 mmol) in water (5 mL) dropwise, maintaining temperature < 5°C.
- Reaction: Stir at 0°C for 1 hour, then allow to warm to room temperature over 2 hours. Evolution of gas indicates reaction progress.
- Workup: Quench with saturated (to remove excess iodine). Extract with EtOAc, wash with brine, dry over , and concentrate. Purify via flash chromatography (Hexane/EtOAc).

Scope: Primary and secondary amines. Aniline derivatives require harsher conditions.

Parameter	Condition	Note
Solvent	DMF or DMSO	Polar aprotic solvents stabilize the Meisenheimer-like transition state.
Base	or	2-3 equivalents. often improves yields for steric amines.
Temperature	80°C - 100°C	Higher temps may degrade the thiadiazole ring.
Time	4 - 12 hours	Monitor by TLC/LCMS.

#### Step-by-Step:

- Dissolve 2-iodo-5-substituted-1,3,4-thiadiazole (1.0 equiv) and the amine (1.2 - 1.5 equiv) in anhydrous DMF (0.2 M concentration).
- Add  
(2.0 equiv).[2]
- Heat to 80°C under an inert atmosphere (  
).
- Critical Step: If conversion is low after 4 hours, add a catalytic amount of CuI (5 mol%) to switch to a modified Ullmann-type mechanism (technically not pure  
, but effective for iodo-heterocycles).
- Pour into ice water. The product often precipitates. Filter and wash with water.

Scope: Alkyl and aryl thiols.[3] This reaction is extremely facile due to the high nucleophilicity of thiolate anions.

#### Step-by-Step:

- Suspend NaH (1.2 equiv, 60% dispersion) in THF at 0°C.
- Add the thiol (1.1 equiv) dropwise and stir for 15 min to generate the thiolate.
- Add a solution of 2-iodo-1,3,4-thiadiazole (1.0 equiv) in THF.
- Stir at room temperature (RT) for 1-2 hours. Note: Heating is rarely required for thiols.
- Quench with saturated  
  
and extract.

Challenge: Alkoxides are hard bases and can attack the ring sulfur or protons, leading to ring opening.

Optimization:

- Use sterically hindered bases if possible, or generate the alkoxide quantitatively with NaH before addition.
- Temperature Control: Keep reaction  
  
60°C.
- Solvent: Use the alcohol corresponding to the alkoxide as the solvent if possible (e.g., NaOMe in MeOH).

## Comparative Data: Leaving Group Efficiency

The following table summarizes the relative efficiency of halogen leaving groups on the 1,3,4-thiadiazole scaffold for a standard morpholine displacement (DMF, 80°C).

Leaving Group (C-5)	Yield (Morpholine)	Reaction Time	Mechanistic Insight
Fluoro (-F)	>95%	30 min	Fastest  (Addition rate-determining).
Chloro (-Cl)	75-85%	6 hours	Standard substrate; cheap but slower.
Bromo (-Br)	80-90%	4 hours	Good balance of reactivity and stability.
Iodo (-I)	60-80%	4-8 hours	Slower  than F/Cl; Prone to dehalogenation side-products.
Sulfonyl (-SO <sub>2</sub> R)	>90%	1 hour	Excellent leaving group (often better than halogens).

Note: While Iodine is the best leaving group for

or radical processes, in classical

, it is often slower than F or Cl. However, if the mechanism involves any Single Electron Transfer (SET) character (common with electron-rich nucleophiles), the Iodo-derivative performs exceptionally well.

## Troubleshooting & Side Reactions

- Deiodination (Reduction):
  - Symptom: [2][3][4][5][6][7] Formation of 2-substituted-1,3,4-thiadiazole (loss of Iodine) instead of substitution.
  - Cause: High temperatures with amine nucleophiles can lead to reductive dehalogenation.

- Fix: Lower temperature, use a milder base, or switch to the Bromo-derivative if is the only goal.
- Ring Opening:
  - Symptom:[\[2\]](#)[\[3\]](#)[\[4\]](#)[\[5\]](#)[\[6\]](#)[\[7\]](#) Complex mixture, loss of aromatic signals in NMR.
  - Cause: Hydroxide attack at C2/C5 followed by ring cleavage.
  - Fix: Ensure anhydrous conditions. Avoid NaOH/KOH; use Carbonates or organic bases (DIPEA).
- Low Conversion:
  - Fix: The 5-iodo group is less activating than a 5-nitro group. If the reaction is sluggish, microwave irradiation (100°C, 10-30 min) is highly effective for this scaffold.

## References

- Synthesis and Reactivity of 1,3,4-Thiadiazoles. ChemicalBook. Reactivity profiles and physical properties of the thiadiazole ring.
- Nucleophilic Aromatic Substitution (SNAr) Mechanism. Chemistry Steps. Detailed mechanistic overview of leaving group trends (F > Cl > Br > I) in standard SNAr.
- Iodine-mediated synthesis of indolyl-1,3,4-thiadiazole amines. Frontiers in Chemistry. Describes the synthesis of the thiadiazole ring using iodine, providing context for the stability of the scaffold.
- Reactivity of 2-Bromo-5-(methylthio)-1,3,4-thiadiazole. BenchChem. Comparative reactivity data for bromo-thiadiazoles in coupling vs. substitution.
- Nucleophilic Substitution of 1,2,5-Thiadiazoles. MDPI. Parallel chemistry demonstrating SNAr conditions on the isomeric thiadiazole system.

**Need Custom Synthesis?**

BenchChem offers custom synthesis for rare earth carbides and specific isotopic labeling.

Email: [info@benchchem.com](mailto:info@benchchem.com) or [Request Quote Online](#).

## Sources

- [1. researchgate.net](https://www.researchgate.net) [[researchgate.net](https://www.researchgate.net)]
- [2. diva-portal.org](https://diva-portal.org) [[diva-portal.org](https://diva-portal.org)]
- [3. chemrxiv.org](https://chemrxiv.org) [[chemrxiv.org](https://chemrxiv.org)]
- [4. pdf.benchchem.com](https://pdf.benchchem.com) [[pdf.benchchem.com](https://pdf.benchchem.com)]
- [5. researchgate.net](https://www.researchgate.net) [[researchgate.net](https://www.researchgate.net)]
- [6. Nucleophilic Aromatic Substitution - Chemistry Steps](https://www.chemistrysteps.com) [[chemistrysteps.com](https://www.chemistrysteps.com)]
- [7. 16.6 Nucleophilic Aromatic Substitution - Organic Chemistry | OpenStax](https://openstax.org) [[openstax.org](https://openstax.org)]
- To cite this document: BenchChem. [Application Note: Functionalization of 5-Iodo-1,3,4-Thiadiazoles]. BenchChem, [2026]. [Online PDF]. Available at: [<https://www.benchchem.com/product/b6260384/docs#application-note-functionalization-of-5-iodo-1-3-4-thiadiazoles>]

---

**Disclaimer & Data Validity:**

The information provided in this document is for Research Use Only (RUO) and is strictly not intended for diagnostic or therapeutic procedures. While BenchChem strives to provide accurate protocols, we make no warranties, express or implied, regarding the fitness of this product for every specific experimental setup.

**Technical Support:** The protocols provided are for reference purposes. Unsure if this reagent suits your experiment?

**Need Industrial/Bulk Grade?** [Request Custom Synthesis Quote](#)

# BenchChem

Our mission is to be the trusted global source of essential and advanced chemicals, empowering scientists and researchers to drive progress in science and industry.

## Contact

Address: 3281 E Guasti Rd  
Ontario, CA 91761, United States  
Phone: (601) 213-4426  
Email: [info@benchchem.com](mailto:info@benchchem.com)

[Contact our Ph.D. Support Team for a compatibility check](#)