

Technical Support Center: Optimizing 2-Fluorobenzoyl Fluoride Synthesis with TFFH

Author: BenchChem Technical Support Team. **Date:** April 2026

Compound of Interest

Compound Name: 2-fluorobenzoyl fluoride

CAS No.: 13918-90-6

Cat. No.: B6247527

[Get Quote](#)

Welcome to the technical support center for optimizing the synthesis of **2-fluorobenzoyl fluoride** using TFFH (Tetramethylfluoroformamidinium Hexafluorophosphate). This guide is designed for researchers, scientists, and drug development professionals to provide in-depth troubleshooting advice and frequently asked questions to ensure successful and high-yield reactions.

Frequently Asked Questions (FAQs)

Q1: What is TFFH and why is it used for synthesizing **2-fluorobenzoyl fluoride**?

A1: TFFH, or Tetramethylfluoroformamidinium Hexafluorophosphate, is a stable, non-hygroscopic, and easy-to-handle crystalline solid used as a fluorinating agent.^{[1][2]} It is particularly effective for converting carboxylic acids, like 2-fluorobenzoic acid, into their corresponding acyl fluorides.^{[3][4]} Acyl fluorides are valuable reactive intermediates in organic synthesis, offering a balance of reactivity and stability compared to other acyl halides.^[5] TFFH is often preferred over other fluorinating reagents due to its mild reaction conditions, high efficiency, and reduced formation of toxic byproducts.^{[1][6]}

Q2: What is the general reaction mechanism for the conversion of 2-fluorobenzoic acid to **2-fluorobenzoyl fluoride** using TFFH?

A2: The reaction proceeds via the in situ formation of the highly reactive acyl fluoride.^[7] In the presence of a non-nucleophilic base, the carboxylic acid is deprotonated. The resulting carboxylate anion then attacks the electrophilic carbon of TFFH, leading to the formation of the acyl fluoride and tetramethylurea as a byproduct.^{[7][8]} The choice of base and solvent is crucial for optimizing this reaction.

Q3: What are the key advantages of using TFFH over other fluorinating agents like DAST or Deoxo-Fluor?

A3: TFFH offers several advantages:

- **Safety and Handling:** TFFH is a stable, non-hygroscopic solid, making it easier and safer to handle than many other fluorinating agents which can be toxic, moisture-sensitive, or thermally unstable.^{[1][2]}
- **Mild Reaction Conditions:** The reaction typically proceeds at or below room temperature, which helps to minimize side reactions and preserve sensitive functional groups.^[9]
- **High Yields:** TFFH is known for its high efficiency in converting carboxylic acids to acyl fluorides, often resulting in excellent yields.^[10]
- **Reduced Byproducts:** Compared to reagents like DAST, TFFH can lead to a cleaner reaction profile with fewer byproducts.^[6]

Troubleshooting Guide

This section addresses common issues encountered during the synthesis of **2-fluorobenzoyl fluoride** with TFFH and provides actionable solutions.

Problem 1: Low or No Conversion to 2-Fluorobenzoyl Fluoride

Possible Causes & Solutions:

- **Insufficient Base:** The presence of a non-nucleophilic base is critical to deprotonate the carboxylic acid, initiating the reaction.
 - **Recommendation:** Ensure the use of at least one equivalent of a suitable base. For sterically hindered or less reactive acids, increasing the base to 1.5-2.0 equivalents may be beneficial.[1] Commonly used bases include N,N-diisopropylethylamine (DIPEA) or triethylamine (TEA).[1][11]
- **Moisture Contamination:** TFFH is sensitive to water when dissolved in a solvent.[2] Moisture can hydrolyze the TFFH reagent and the resulting acyl fluoride, leading to low yields.
 - **Recommendation:** Use anhydrous solvents and reagents. Dry all glassware thoroughly before use and conduct the reaction under an inert atmosphere (e.g., nitrogen or argon). Ensure your solvent has a low water content (e.g., DMF with <300 ppm water).[2]
- **Inadequate Reaction Time or Temperature:** While the reaction is often rapid, incomplete conversion can occur if the reaction is not allowed to proceed to completion.
 - **Recommendation:** Monitor the reaction progress using an appropriate analytical technique such as ^{19}F NMR or IR spectroscopy.[1] An IR absorption band around 1842 cm^{-1} is characteristic of the acyl fluoride carbonyl stretch.[1] If the reaction is sluggish at 0°C , allowing it to warm to room temperature may be necessary.[11]

Problem 2: Formation of Side Products (e.g., Symmetric Anhydride)

Possible Causes & Solutions:

- **Sub-optimal Stoichiometry:** An incorrect ratio of TFFH to the carboxylic acid can lead to the formation of symmetric anhydrides.
 - **Recommendation:** Use a 1:1 molar ratio of TFFH to 2-fluorobenzoic acid.[2] For challenging substrates, slight excess of TFFH (e.g., 1.1 equivalents) might be beneficial, but this should be optimized.
- **Inefficient Acyl Fluoride Formation:** In some cases, especially with hindered acids, the conversion to the acyl fluoride may be slow, allowing for side reactions to occur.

- Recommendation: The addition of a fluoride additive like benzyltriphenylphosphonium dihydrogen trifluoride (PTF) can improve the efficiency of acyl fluoride formation and minimize anhydride byproducts.[1]

Problem 3: Difficulty in Isolating the Product

Possible Causes & Solutions:

- Hydrolysis during Workup: Acyl fluorides are more stable than acyl chlorides but can still hydrolyze, especially in the presence of water and base.
 - Recommendation: Perform the workup at low temperatures and minimize contact with aqueous solutions. If an aqueous workup is necessary, use cold, dilute acid to neutralize the base and quickly extract the product into an organic solvent.
- Volatility of the Product: Low molecular weight acyl fluorides can be volatile.
 - Recommendation: Use caution during solvent removal. Employ rotary evaporation at reduced pressure and low temperature. For highly volatile products, distillation under reduced pressure may be a suitable purification method.

Experimental Protocols

General Procedure for the Synthesis of 2-Fluorobenzoyl Fluoride

This protocol provides a starting point for the synthesis. Optimization of specific parameters may be required.

Materials:

- 2-Fluorobenzoic acid
- TFFH (Tetramethylfluoroformamidinium Hexafluorophosphate)
- N,N-diisopropylethylamine (DIPEA) or Triethylamine (TEA)
- Anhydrous Dichloromethane (DCM) or Acetonitrile

Procedure:

- To a dry, inert-atmosphere-flushed round-bottom flask, add 2-fluorobenzoic acid (1.0 eq).
- Dissolve the acid in anhydrous DCM or acetonitrile.
- Cool the solution to 0°C in an ice bath.
- Add TFFH (1.0 - 1.1 eq) to the solution with stirring.
- Slowly add DIPEA or TEA (1.0 - 1.5 eq) dropwise to the reaction mixture.
- Stir the reaction at 0°C for 15-30 minutes, then allow it to warm to room temperature.[11]
- Monitor the reaction progress by TLC, ¹⁹F NMR, or IR spectroscopy until the starting material is consumed (typically 1-3 hours).[1]
- Upon completion, the reaction mixture can be used directly for subsequent steps, or the product can be isolated.

Workup and Isolation:

- Filter the reaction mixture to remove any precipitated salts.
- Carefully concentrate the filtrate under reduced pressure at low temperature to remove the solvent.
- The crude **2-fluorobenzoyl fluoride** can be purified by distillation under reduced pressure.

Data Presentation

Table 1: Recommended Reaction Parameters

Parameter	Recommended Value	Rationale
Stoichiometry (Acid:TFFH:Base)	1 : 1-1.1 : 1-1.5	Ensures complete activation of the carboxylic acid while minimizing side reactions.
Solvent	Anhydrous DCM, Acetonitrile, DMF	Aprotic solvents that are compatible with the reagents. Low water content is critical.[2]
Temperature	0°C to Room Temperature	Mild conditions to prevent degradation of reagents and products.[11]
Reaction Time	1 - 3 hours	Typically sufficient for complete conversion, but should be monitored.[1]

Visualizations

Reaction Mechanism

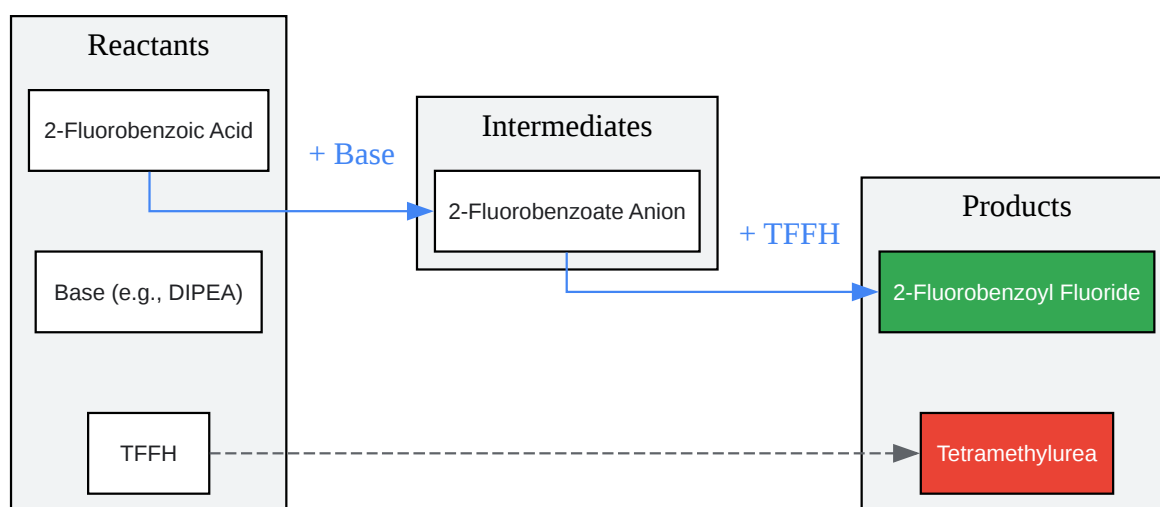

[Click to download full resolution via product page](#)

Caption: General mechanism for the formation of **2-fluorobenzoyl fluoride** using TFFH.

Troubleshooting Workflow

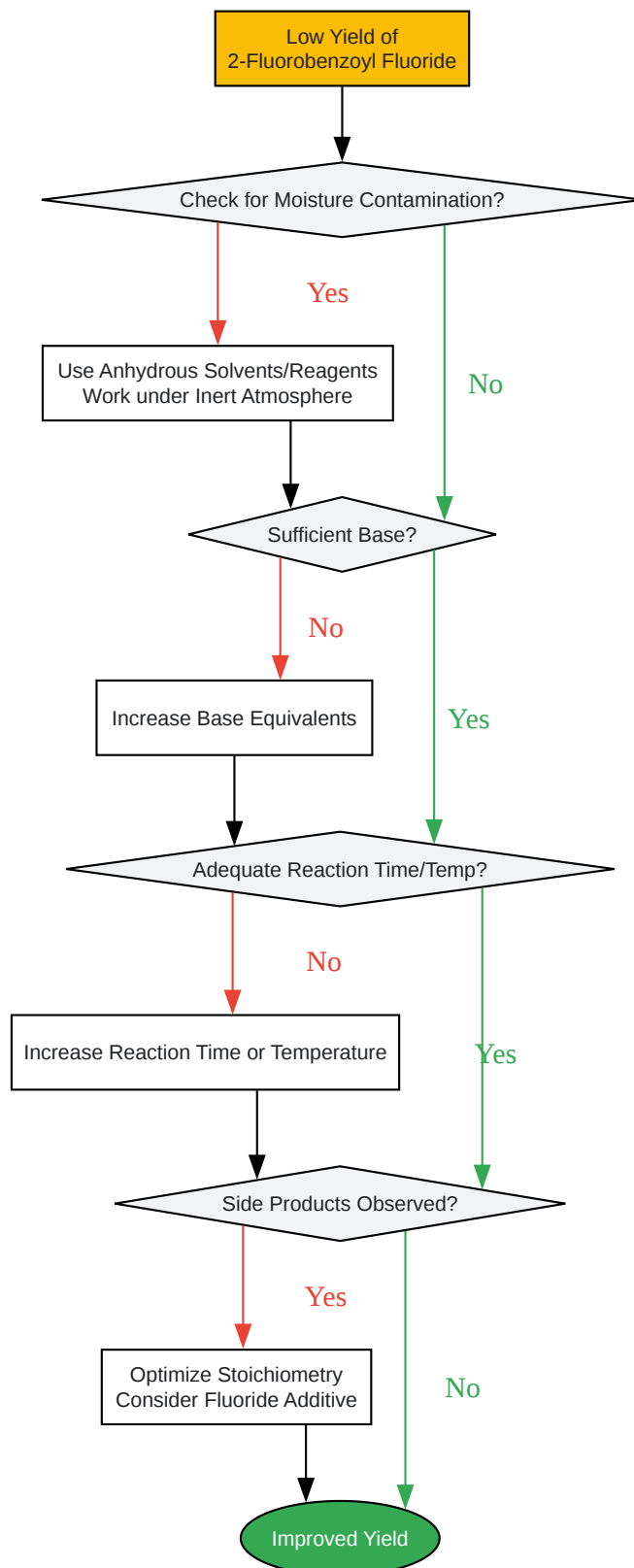

[Click to download full resolution via product page](#)

Caption: A workflow for troubleshooting low yields in the synthesis of **2-fluorobenzoyl fluoride**.

References

- El-Faham, A., & Abdul-Ghani, M. (2003). TFFH AS A USEFUL REAGENT FOR THE CONVERSION OF CARBOXYLIC ACIDS TO ANILIDES, HYDRAZIDES AND AZIDES.
- Xiao, J.-C., et al. (2018). Tertiary-Amine-Initiated Synthesis of Acyl Fluorides from Carboxylic Acids and CF₃SO₂OCF₃. *Chemistry – An Asian Journal*, 13(17), 2416-2419.
- El-Faham, A., & Khattab, S. N. (2009). Tetramethylfluoroformamidinium Hexafluorophosphate (TFFH) in Peptide and Organic Synthesis. *Synlett*, 2009(06), 886-904.
- BenchChem. (2025). A Comparative Guide to TFFH and BTFFH Coupling Reagents in Peptide Synthesis. BenchChem.
- ThermoFisher Scientific. (n.d.). TFFH (N,N,N',N'-Tetramethylfluoroformamidinium hexafluorophosphate) Technical Note. ThermoFisher Scientific.
- Li, L., et al. (2021). Deoxyfluorination of Carboxylic Acids with CpFluor: Access to Acyl Fluorides and Amides. *Organic Letters*, 23(5), 1676-1681.
- BenchChem. (2025). The Role of TFFH in Minimizing Racemization in Fmoc-Amino Acid Synthesis. BenchChem.
- Bellavance, G., et al. (2012). Tetramethylfluoroformamidinium Hexafluorophosphate (TFFH)
- Beilstein Journal of Organic Chemistry. (2024). Direct synthesis of acyl fluorides from carboxylic acids using benzothiazolium reagents. *Beilstein Journal of Organic Chemistry*, 20, 775-783.
- Huang, X., et al. (2021). Electrophilic N-Trifluoromethylthiophthalimide as a Fluorinated Reagent in the Synthesis of Acyl Fluorides. KAUST Repository.
- Organic Chemistry Portal. (2012). Tetramethylfluoroformamidinium Hexafluorophosphate (TFFH)
- Pittelkow, M., et al. (2004).
- Kim, D., & Lim, H. N. (2020). Synthesis of Acyl Fluorides via DAST-Mediated Fluorinative C–C Bond Cleavage of Activated Ketones. *Organic Letters*, 22(19), 7465-7469.
- Yang, J., et al. (2011). Facile and Selective Synthesis of 2,3,4,5-Tetrafluorobenzoyl Chloride with Triphosgene. *Asian Journal of Chemistry*, 23(11), 4923-4925.
- TCI Chemicals. (n.d.). Powerful and Easy Peptide Coupling Reagent. TCI Chemicals.
- Sigma-Aldrich. (n.d.).
- Ulven, T., et al. (2015). Applying old tricks to new problems: Acyl Fluorides in Sterically Hindered Amide Coupling. *Synfacts*, 11(01), 0001.
- Organic Chemistry Explained. (2022, January 24). TFFH Peptide Coupling Mechanism | Organic Chemistry [Video]. YouTube.

- Advanced ChemTech. (n.d.). TFFH. Advanced ChemTech.
- El-Faham, A., & Khattab, S. N. (2009). Utilization of N,N,N',N'-Tetramethylfluoroformamidinium Hexafluorophosphate (TFFH) in Peptide and Organic Synthesis. *Synlett*, 2009(06), 886-904.
- Tokyo Chemical Industry. (n.d.). Development of Easy-to-handle and Useful Fluorine-introducing Reagents. Tokyo Chemical Industry.
- ResearchGate. (n.d.). Structures of fluorinating reagents [Image].
- ResearchGate. (2019). Tetramethylfluoroformamidinium Hexafluorophosphate (TFFH) Deoxofluorination.
- BenchChem. (2025). An In-depth Technical Guide to the Synthesis of 2-fluoro-N-(morpholin-4-yl)benzamide. BenchChem.
- Google Patents. (n.d.).
- Agency for Toxic Substances and Disease Registry. (2003). Analytical Methods. In *Toxicological Profile for Fluorides, Hydrogen Fluoride, and Fluorine*.
- ResearchGate. (n.d.). Synthesis of N-protected amino acid fluoride using TFFH (77) [Image].
- Yu, Y., & Dong, C.-Z. (2014). An efficient colorimetric and fluorescent probe for detection of fluoride ion based on a benzothiadiazole derivative. *Analytical Methods*, 6(15), 5674-5677.
- Organic Chemistry Portal. (n.d.).
- Beilstein Journal of Organic Chemistry. (2024). Direct synthesis of acyl fluorides from carboxylic acids using benzothiazolium reagents. *Beilstein Journal of Organic Chemistry*, 20, 775-783.
- PrepChem.com. (n.d.). Synthesis of 2-fluorobenzoyl chloride. PrepChem.com.
- Macdonald, A. M. G. (1970). Methods of Analysis for Fluorine. In *Pharmacology of Fluorides* (pp. 1-47). Springer.

Need Custom Synthesis?

BenchChem offers custom synthesis for rare earth carbides and specific isotopic labeling.

Email: info@benchchem.com or [Request Quote Online](#).

Sources

- [1. luxembourg-bio.com](http://1.luxembourg-bio.com) [luxembourg-bio.com]
- [2. documents.thermofisher.com](http://2.documents.thermofisher.com) [documents.thermofisher.com]
- [3. sioc.cas.cn](http://3.sioc.cas.cn) [sioc.cas.cn]
- [4. sioc.cas.cn](http://4.sioc.cas.cn) [sioc.cas.cn]

- [5. Direct synthesis of acyl fluorides from carboxylic acids using benzothiazolium reagents - PMC \[pmc.ncbi.nlm.nih.gov\]](#)
- [6. blogs.rsc.org \[blogs.rsc.org\]](#)
- [7. pdf.benchchem.com \[pdf.benchchem.com\]](#)
- [8. youtube.com \[youtube.com\]](#)
- [9. Tetramethylfluoroformamidinium Hexafluorophosphate \(TFFH\) as a Mild Deoxofluorination Reagent \[organic-chemistry.org\]](#)
- [10. TFFH as an Excellent Reagent for Acylation of Alcohols, Thiols and Dithiocarbamates \[organic-chemistry.org\]](#)
- [11. tandfonline.com \[tandfonline.com\]](#)
- To cite this document: BenchChem. [Technical Support Center: Optimizing 2-Fluorobenzoyl Fluoride Synthesis with TFFH]. BenchChem, [2026]. [Online PDF]. Available at: [\[https://www.benchchem.com/product/b6247527/docs#technical-support-center-optimizing-2-fluorobenzoyl-fluoride-synthesis-with-tffh\]](https://www.benchchem.com/product/b6247527/docs#technical-support-center-optimizing-2-fluorobenzoyl-fluoride-synthesis-with-tffh)

Disclaimer & Data Validity:

The information provided in this document is for Research Use Only (RUO) and is strictly not intended for diagnostic or therapeutic procedures. While BenchChem strives to provide accurate protocols, we make no warranties, express or implied, regarding the fitness of this product for every specific experimental setup.

Technical Support: The protocols provided are for reference purposes. Unsure if this reagent suits your experiment?

Need Industrial/Bulk Grade? [Request Custom Synthesis Quote](#)

BenchChem

Our mission is to be the trusted global source of essential and advanced chemicals, empowering scientists and researchers to drive progress in science and industry.

Contact

Address: 3281 E Guasti Rd
Ontario, CA 91761, United States
Phone: (601) 213-4426
Email: info@benchchem.com

Contact our Ph.D. Support Team for a compatibility check