

Optimizing lithiation temperature for 4-fluoro-2-iodobenzene functionalization

Author: BenchChem Technical Support Team. **Date:** April 2026

Compound of Interest

Compound Name: 2-(4-fluoro-2-iodophenyl)ethan-1-ol

CAS No.: 1243075-80-0

Cat. No.: B6234363

[Get Quote](#)

Technical Support Center: Optimizing Lithiation of 4-fluoro-2-iodobenzene

Welcome to the technical support center for the functionalization of 4-fluoro-2-iodobenzene via lithium-halogen exchange. This guide is designed for researchers, chemists, and drug development professionals who are looking to optimize this critical synthetic step. Here, we address common challenges and frequently asked questions to help you achieve higher yields, better selectivity, and more reproducible results.

Section 1: Troubleshooting Guide

This section addresses specific experimental issues in a problem-and-solution format.

Issue 1: Low or No Conversion of Starting Material

Symptom: After quenching the reaction and work-up, analysis (TLC, GC-MS, NMR) shows predominantly unreacted 4-fluoro-2-iodobenzene.

Potential Causes & Solutions:

- Inactive Lithiating Agent: n-Butyllithium (n-BuLi) is highly reactive and degrades upon exposure to moisture or air.
 - Solution: Always use a freshly opened bottle of n-BuLi or titrate older bottles before use. A common method is the double titration procedure described by Gilman. Ensure your entire apparatus is rigorously dried and maintained under an inert atmosphere (Argon or Nitrogen).^[1]
- Incorrect Stoichiometry: While the iodine-lithium exchange is typically fast and clean, using an insufficient amount of n-BuLi will lead to incomplete conversion.^[1]
 - Solution: Use a slight excess of n-BuLi (typically 1.05-1.2 equivalents). This ensures that trace amounts of protic impurities in the solvent or on the glassware are quenched without consuming the amount needed for the primary reaction.
- Reaction Temperature is Too Low: While low temperatures are critical, extremely low temperatures can significantly slow down the rate of lithium-halogen exchange, especially if the reagent concentrations are low.
 - Solution: The "sweet spot" for this reaction is often between -78 °C and -100 °C.^[1] If you suspect the temperature is too low (e.g., using a liquid nitrogen/isopropanol bath that has cooled too far), try a well-controlled dry ice/acetone bath at -78 °C.
- Poor Substrate or Solvent Quality: Protic impurities in the starting material or solvent will rapidly quench the organolithium reagent.
 - Solution: Ensure 4-fluoro-2-iodobenzene is pure. Dry your solvent (typically THF or diethyl ether) rigorously before use, for example, by distilling from sodium/benzophenone under an inert atmosphere.^[1]

Issue 2: Significant Formation of Side Products

Symptom: The crude product mixture contains multiple spots on TLC or peaks in GC-MS, including potential homocoupling products or protonated (de-iodinated) starting material.

Potential Causes & Solutions:

- **Temperature is Too High:** This is the most common cause of side reactions. The generated 2-fluoro-6-lithiodobenzene intermediate is thermally unstable. At temperatures above approximately $-60\text{ }^{\circ}\text{C}$, it can eliminate lithium fluoride to form a highly reactive benzyne intermediate.^[2] This benzyne can then be trapped by other nucleophiles in the mixture, leading to a complex product profile.
 - **Solution:** Maintain a strict low-temperature profile throughout the addition of n-BuLi and before the addition of the electrophile. A temperature of $-78\text{ }^{\circ}\text{C}$ is a standard starting point. ^[3] For particularly sensitive substrates, temperatures as low as $-100\text{ }^{\circ}\text{C}$ may be necessary.^[1]
- **Premature Quenching/Proton Source:** If the reaction is inadvertently quenched with a proton source (like moisture) before the electrophile is added, you will form 1-fluoro-3-iodobenzene.
 - **Solution:** Re-verify that the entire system is under a positive pressure of a dry, inert gas. Ensure the electrophile is also anhydrous.
- **Slow Addition of Electrophile:** Allowing the aryllithium intermediate to sit for extended periods, even at low temperatures, can lead to decomposition.
 - **Solution:** Add the electrophile reasonably quickly after the lithium-halogen exchange is complete (typically after 15-30 minutes of stirring at low temperature).

Workflow for Troubleshooting Low Yield

The following diagram outlines a logical workflow for diagnosing and solving low-yield issues.

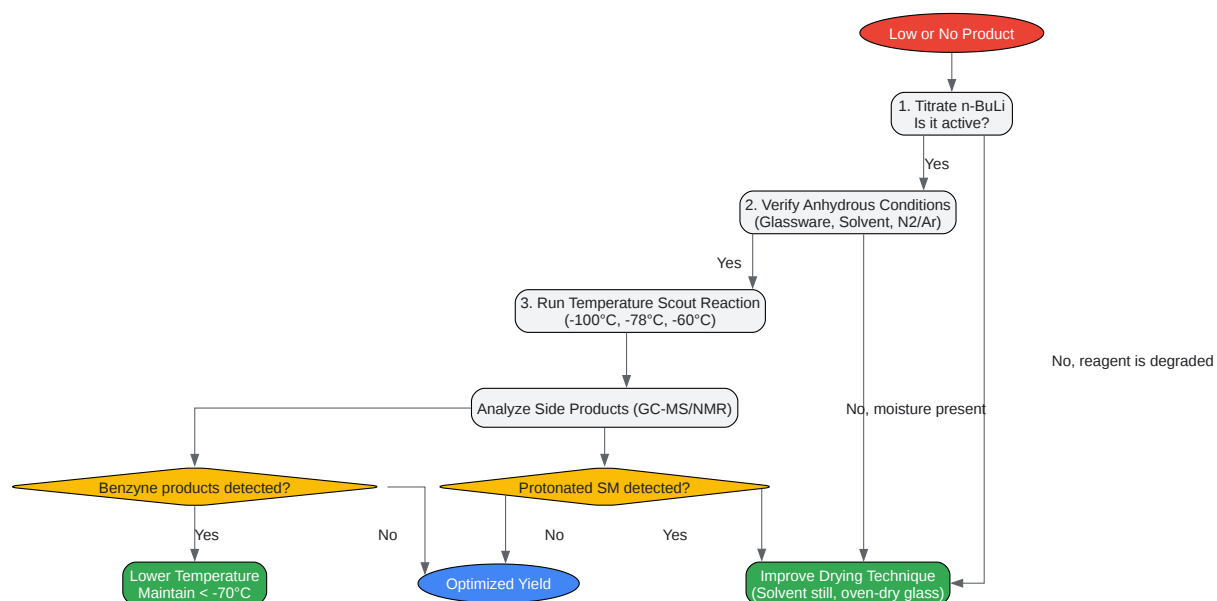

[Click to download full resolution via product page](#)

Caption: A logical troubleshooting workflow for low-yield lithiation reactions.

Section 2: Frequently Asked Questions (FAQs)

Q1: Why is low temperature so critical for the lithiation of 4-fluoro-2-iodobenzene?

Answer: There are two primary reasons. First, the carbon-lithium bond is highly polarized and reactive. Low temperatures temper the reactivity of the n-BuLi, preventing unwanted side reactions like attacking the solvent (THF) or other functional groups. Second, and more importantly, the resulting aryllithium species, ortho-lithiated fluorobenzene derivatives, are thermally unstable. The fluorine atom is a powerful ortho-directing group but also activates the ring for elimination.^{[4][5]} At elevated temperatures (typically > -40 °C), the intermediate can readily undergo elimination of lithium fluoride (LiF) to form a highly reactive benzyne intermediate, which leads to a host of undesired side products.^[2] Precise temperature control is essential to form the desired intermediate and trap it before it can decompose.^[2]

Q2: What is the optimal temperature range for the iodine-lithium exchange?

Answer: The optimal temperature is a balance between reaction rate and stability. For the vast majority of applications involving 4-fluoro-2-iodobenzene, the recommended temperature range is -78 °C to -100 °C. Iodine-lithium exchange is an extremely fast reaction, even at these cryogenic temperatures.^{[1][6]} Operating within this window ensures that the exchange proceeds to completion while minimizing the risk of benzyne formation.

The following table provides a general guide to the expected outcomes at different temperatures.

Temperature Range	Expected Outcome	Primary Risks
0 °C to -40 °C	Not Recommended. High risk of rapid decomposition.	Benzyne formation, polymerization, complex mixture of products.[2]
-40 °C to -60 °C	High Risk. Possible for very fast subsequent trapping.	Significant benzyne formation is still a major concern.[2]
-60 °C to -78 °C	Optimal Working Range. Good balance of reaction rate and stability.	Minimal risk if reaction time is controlled.[3]
-78 °C to -100 °C	Highly Recommended. Maximizes stability of the aryllithium.	Reaction rate may be slightly slower, but often negligible.[1]

Q3: Which lithiating agent is best: n-BuLi, s-BuLi, or LDA?

Answer: For this specific transformation, n-BuLi is the reagent of choice. The goal is a lithium-halogen exchange, where the lithium atom selectively replaces the iodine atom. The reactivity order for this exchange is I > Br > Cl >> F.[7][8] n-BuLi is highly effective for iodine-lithium exchange.

- s-BuLi and t-BuLi: These are more reactive and basic than n-BuLi. While they would also perform the exchange, they have a higher tendency to act as a base and perform competitive ortho-lithiation (deprotonation) at the position between the fluorine and iodine, which is not the desired outcome.
- LDA (Lithium diisopropylamide): LDA is a strong, non-nucleophilic base. It is primarily used for deprotonation (C-H lithiation), not lithium-halogen exchange. It would likely not be effective for this transformation.[9]

Q4: Can you provide a standard protocol for temperature optimization?

Answer: Yes. A small-scale scouting experiment is highly recommended.

Protocol: Small-Scale Temperature Optimization

- Preparation: In three separate, flame-dried, 25 mL round-bottom flasks equipped with stir bars and under a positive pressure of Argon, dissolve 4-fluoro-2-iodobenzene (e.g., 1.0 mmol) in anhydrous THF (10 mL).
- Cooling:
 - Cool Flask A to -100 °C (liquid N₂ / ethyl acetate bath).
 - Cool Flask B to -78 °C (dry ice / acetone bath).
 - Cool Flask C to -60 °C (dry ice / chloroform bath).
- Lithiation: To each flask, add n-BuLi (1.1 mmol, 1.1 eq) dropwise via syringe over 5 minutes.
- Stirring: Stir each reaction at its respective temperature for 20 minutes.
- Quenching: Add a standard, reliable electrophile to each flask (e.g., benzaldehyde, 1.2 mmol).
- Warm & Work-up: Allow all flasks to warm to room temperature, then quench with saturated aqueous NH₄Cl. Perform a standard aqueous work-up and extraction.
- Analysis: Analyze the crude product from each reaction by GC-MS or ¹H NMR to determine the conversion and the ratio of desired product to side products. This will reveal the optimal temperature for your specific setup and reagents.

The following diagram illustrates this experimental workflow.

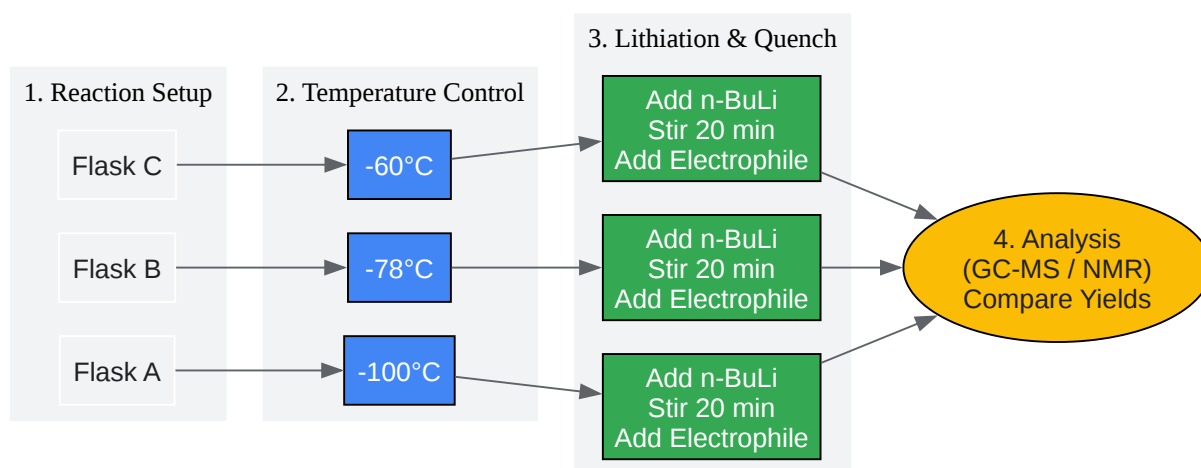

[Click to download full resolution via product page](#)

Caption: Experimental workflow for parallel temperature scouting.

References

- Schlosser, M., et al. (2015). Substituent effects on the relative rates and free energies of ortho-lithiation reactions: families of fluorobenzenes as the substrates. *ARKIVOC*, 2015(iv), 48-65.
- "Troubles with Lithium-Halogen exchange reaction." (2019). Science Madness Discussion Board.
- Takahashi, H., et al. (2019). Selective Halogen-Lithium Exchange of 1,2-Dihaloarenes for Successive [2+4] Cycloadditions of Arynes and Isobenzofurans. *Molecules*, 24(21), 3875.
- Schlosser, M., et al. (2015). Substituent effects on the relative rates and free energies of ortho-lithiation reactions: families of fluorobenzenes as the substrates. University of Michigan Library Deep Blue.
- Schlosser, M., et al. (2006). Substituent effects on the relative rates and free energies of ortho-lithiation reactions: families of fluorobenzenes as the substrates. EPFL Infoscience.

- Macmillan Group Meeting. (2007). The Mechanism of Lithium-Halogen Exchange.
- "Li Halogen Exchange?" (2021). Reddit r/Chempros.
- Le, T. V., & Daugulis, O. (2022). In situ ortho-lithiation/functionalization of pentafluorosulfanyl arenes. *Chemical Communications*, 58(4), 537-540.
- Movsisyan, M., et al. (2016). Advances in Flow Chemistry for Organolithium-Based Synthesis: A Process Perspective. *Chemical Engineering Journal*, 294, 213-224.
- Gilman, H., & Morton, J. W. (1954). Metalation as a Side Reaction in the Preparation of Organolithium Compounds. *Journal of the American Chemical Society*, 76(23), 5881-5883.
- Dunn, A. L., et al. (2019). Continuous flow processing of asymmetric intramolecular cyclisations via 'Memory of Chirality'. University College Cork CORA.
- Bailey, W. F., et al. (2009). Optimization of Organolithium Reactions. *Organic Process Research & Development*, 13(2), 144-151.
- Ziegler, F. E., & Fowler, K. W. (1988). Selective halogen-lithium exchange reactions of 2-(2'-halophenyl)ethyl halides: synthesis of 4,5-methylenedioxybenzocyclobutene. *Organic Syntheses*, 6, 47.
- "Metal-halogen exchange." Wikipedia.
- Bailey, W. F. (2009). The Lithium-Halogen Exchange Reaction in Process Chemistry. *The Chemistry of Organolithium Compounds*, 2, 639-669.
- Yesiloz, G., et al. (2024). Machine learning guided multi-objective optimization of an ultrafast lithium-halogen exchange reaction in flow. *Reaction Chemistry & Engineering*, 9(1), 118-126.
- Snieckus, V. (1990). Heteroatom-facilitated lithiation reactions. *Chemical Reviews*, 90(6), 879-933.
- Wang, Z., et al. (2023). Revisiting Fluorobenzene as Diluents in Ether-Based Electrolytes for Lithium Metal Batteries. ResearchGate.

- Siegel, D. (n.d.). Lithium-halogen exchange. University of Texas.
- "Lithiation." Vapourtec.
- "Lithiation in Flow: n-Butyl Lithiation and electrophile addition." Amar Equipment.
- Tropin, E. V., et al. (2023). The Role of Conjugation in the Halogen–Lithium Exchange Selectivity: Lithiation of 4,6,7,9-Tetrabromo-1,3-dimethyl-2,3-dihydro-1H-perimidine. *Chemistry – A European Journal*, e202301439.
- Bailey, W. F., et al. (2009). Optimization of Organolithium Reactions. ResearchGate.
- Le, T. V., & Daugulis, O. (2022). In situ ortho-lithiation/functionalization of pentafluorosulfanyl arenes. *Chemical Communications*, 58, 537-540.
- Britton, J., & Raston, C. L. (2017). Continuous flow intensification of ortho-lithiation at ambient conditions. ECI Digital Archives.

Need Custom Synthesis?

BenchChem offers custom synthesis for rare earth carbides and specific isotopic labeling.

Email: info@benchchem.com or [Request Quote Online](#).

Sources

- [1. Sciencemadness Discussion Board - Troubles with Lithium-Halogen exchange reaction. - Powered by XMB 1.9.11 \[sciencemadness.org\]](#)
- [2. In situ ortho-lithiation/functionalization of pentafluorosulfanyl arenes - PMC \[pmc.ncbi.nlm.nih.gov\]](#)
- [3. Selective Halogen-Lithium Exchange of 1,2-Dihaloarenes for Successive \[2+4\] Cycloadditions of Arynes and Isobenzofurans - PMC \[pmc.ncbi.nlm.nih.gov\]](#)
- [4. researchgate.net \[researchgate.net\]](#)
- [5. quod.lib.umich.edu \[quod.lib.umich.edu\]](#)
- [6. myers.faculty.chemistry.harvard.edu \[myers.faculty.chemistry.harvard.edu\]](#)
- [7. macmillan.princeton.edu \[macmillan.princeton.edu\]](#)

- [8. Metal–halogen exchange - Wikipedia \[en.wikipedia.org\]](#)
- [9. vapourtec.com \[vapourtec.com\]](#)
- To cite this document: BenchChem. [Optimizing lithiation temperature for 4-fluoro-2-iodobenzene functionalization]. BenchChem, [2026]. [Online PDF]. Available at: [<https://www.benchchem.com/product/b6234363/docs#optimizing-lithiation-temperature-for-4-fluoro-2-iodobenzene-functionalization>]

Disclaimer & Data Validity:

The information provided in this document is for Research Use Only (RUO) and is strictly not intended for diagnostic or therapeutic procedures. While BenchChem strives to provide accurate protocols, we make no warranties, express or implied, regarding the fitness of this product for every specific experimental setup.

Technical Support: The protocols provided are for reference purposes. Unsure if this reagent suits your experiment?

Need Industrial/Bulk Grade? [Request Custom Synthesis Quote](#)

BenchChem

Our mission is to be the trusted global source of essential and advanced chemicals, empowering scientists and researchers to drive progress in science and industry.

Contact

Address: 3281 E Guasti Rd
Ontario, CA 91761, United States
Phone: (601) 213-4426
Email: info@benchchem.com

[Contact our Ph.D. Support Team for a compatibility check](#)