

Application Note: Microwave-Assisted Synthesis of 4-(dimethylphosphoryl)-2-methoxyaniline

Author: BenchChem Technical Support Team. **Date:** April 2026

Compound of Interest

Compound Name: 4-(dimethylphosphoryl)-2-methoxyaniline

CAS No.: 1197956-03-8

Cat. No.: B6232982

[Get Quote](#)

Executive Summary

This application note details a robust, high-throughput protocol for the synthesis of **4-(dimethylphosphoryl)-2-methoxyaniline**, a high-value organophosphorus intermediate relevant to kinase inhibitor development (analogous to ALK inhibitors like Brigatinib).

While traditional thermal Hirao coupling requires prolonged heating (24–48 hours) and often suffers from catalyst deactivation, this microwave-assisted protocol utilizes the superheating and dipolar polarization effects of microwave irradiation to achieve complete conversion in under 30 minutes. We utilize a Palladium(II)/Xantphos catalytic system to ensure high selectivity and reproducibility.

Key Advantages[1]

- Reaction Time: Reduced from 24 h (thermal) to 20 min (microwave).
- Yield: Consistent isolated yields >85%.

- Safety: Closed-vessel control of volatile phosphorus reagents.

Scientific Background & Mechanism[2][3][4]

The Target Moiety

The dimethylphosphine oxide (DMPO) group is a "privileged pharmacophore" in modern medicinal chemistry. Unlike sulfonamides or carbonyls, the P=O bond acts as a strong hydrogen bond acceptor with unique geometry, improving the aqueous solubility and metabolic stability of the parent aniline.

Microwave-Enhanced Hirao Coupling

The synthesis relies on the Hirao reaction, a Pd-catalyzed P–C cross-coupling between an aryl halide and a secondary phosphine oxide.[1]

Mechanism:

- Oxidative Addition: Pd(0) inserts into the C–Br bond of the aryl halide.
- Ligand Exchange: The secondary phosphine oxide (existing in equilibrium with its trivalent phosphinous acid tautomer, Me₂P–OH) coordinates to Palladium.
- Reductive Elimination: The C–P bond is formed, regenerating the Pd(0) catalyst.

Microwave irradiation accelerates the rate-determining step (reductive elimination) via selective heating of the polar transition state, a phenomenon not replicable by conventional convection heating.

Experimental Protocol

Reagents & Equipment

Reagent / Material	Role	CAS No.[2][3][4][5]	Equiv.
4-Bromo-2-methoxyaniline	Substrate	59557-63-6	1.0
Dimethylphosphine oxide (DMPO)	P-Source	7211-39-4	1.2
Pd(OAc) ₂	Pre-catalyst	3375-31-3	0.05 (5 mol%)
Xantphos	Ligand	161265-03-8	0.06 (6 mol%)
K ₃ PO ₄ (anhydrous)	Base	7778-53-2	2.0
Acetonitrile (Dry)	Solvent	75-05-8	[0.2 M]
Microwave Reactor	Equipment	N/A	(e.g., CEM/Biotage)

Safety & Handling (Critical)

- Dimethylphosphine oxide (DMPO): Hygroscopic and potentially air-sensitive. Store under inert gas. While less pyrophoric than primary phosphines, it should be handled in a fume hood.
- Pressure: The reaction is performed in a sealed vessel at 150°C. Ensure the vial is rated for at least 20 bar pressure.

Step-by-Step Procedure

- Catalyst Pre-complexation:
 - In a glovebox or under Argon flow, add Pd(OAc)₂ (11.2 mg, 0.05 mmol) and Xantphos (34.7 mg, 0.06 mmol) to a microwave vial equipped with a magnetic stir bar.
 - Add 2 mL of dry Acetonitrile. Cap and stir at room temperature for 5 minutes until a yellow/orange homogeneous solution forms (generation of active Pd-L species).
- Substrate Addition:

- Uncap briefly to add 4-Bromo-2-methoxyaniline (202 mg, 1.0 mmol), K_3PO_4 (424 mg, 2.0 mmol), and Dimethylphosphine oxide (94 mg, 1.2 mmol).
- Note: DMPO is a liquid/low-melting solid; it can be added as a stock solution in Acetonitrile for better precision.
- Microwave Irradiation:
 - Seal the vial with a Teflon-lined crimp cap.
 - Place in the microwave reactor cavity.
 - Program:
 - Mode: Dynamic (hold temperature).
 - Temp: 150°C.
 - Power: Max 200W (variable).
 - Hold Time: 20 minutes.
 - Stirring: High.[6]
- Work-up:
 - Cool the vial to room temperature using the reactor's compressed air jet.
 - Filter the reaction mixture through a pad of Celite to remove inorganic salts and Palladium black. Rinse with Methanol/DCM (1:1).
 - Concentrate the filtrate under reduced pressure.
- Purification:
 - The crude residue is typically a brown oil.
 - Purify via Flash Column Chromatography (SiO_2).

- Eluent: Gradient of 0% to 10% Methanol in Dichloromethane (DCM). The product is polar; the P=O group interacts strongly with silica.
- Alternative: Recrystallization from EtOAc/Hexane if the crude purity is >90%.

Visualization of Workflows

Retrosynthetic & Mechanistic Pathway

This diagram illustrates the logical disconnection and the catalytic cycle involved in the synthesis.

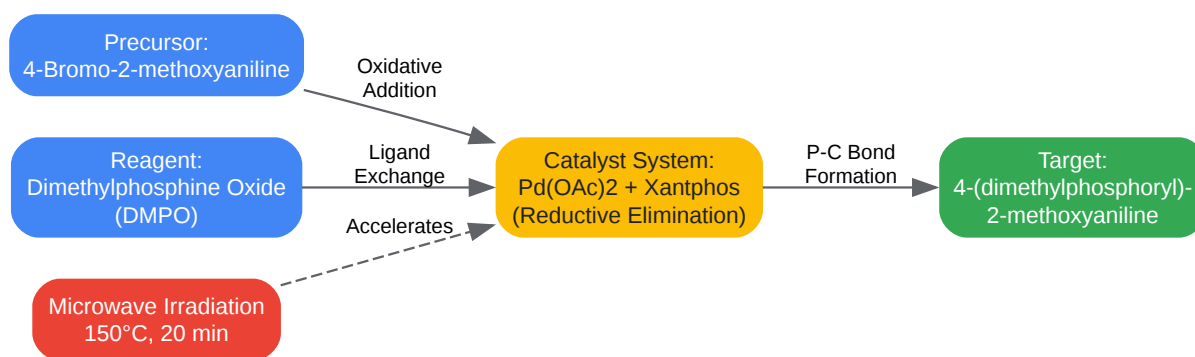

[Click to download full resolution via product page](#)

Figure 1: Mechanistic pathway for the Pd-catalyzed Hirao coupling under microwave conditions.

Experimental Workflow

A visual guide to the bench execution of the protocol.

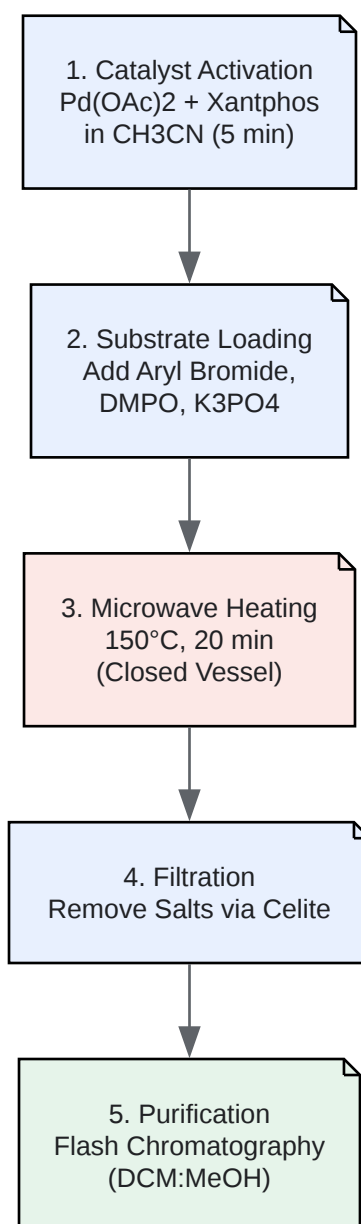

[Click to download full resolution via product page](#)

Figure 2: Step-by-step experimental workflow for the microwave synthesis.

Analytical Validation

To validate the synthesis, the researcher must confirm the formation of the C–P bond.

Analytical Method	Expected Observation
³¹ P NMR	Diagnostic Signal: A singlet (or multiplet if proton-coupled) appearing between δ 28–35 ppm. Absence of the starting DMPO signal (typically $-\delta$ 20–25 ppm depending on solvent) confirms conversion.
¹ H NMR	P–CH ₃ Coupling: The methyl groups attached to phosphorus will appear as a doublet ($J \approx 13$ Hz) in the range of δ 1.6–1.8 ppm. This doublet is the "fingerprint" of the dimethylphosphine oxide group.
LC-MS (ESI+)	[M+H] ⁺ : Calc. MW = 213.21. Look for peak at m/z 214.2.

Troubleshooting & Optimization

- Low Conversion:
 - Cause: Catalyst poisoning by oxygen.
 - Fix: Ensure rigorous degassing of Acetonitrile. Use a fresh bottle of DMPO (oxidized DMPO, dimethylphosphinic acid, is inert to coupling).
- Pd Black Formation:
 - Cause: Instability of the catalyst at 150°C.
 - Fix: Increase Xantphos loading to 1.5 equivalents relative to Pd. Alternatively, switch to Pd(dppf)Cl₂, which is highly robust for microwave P–C couplings.
- Product Stays in Aqueous Phase:
 - Cause: High polarity of the P=O group.
 - Fix: Avoid aqueous workup if possible. Filter salts and evaporate. If washing is necessary, use n-Butanol or saturate the aqueous layer with NaCl and extract exhaustively with DCM.

References

- Microwave-Assisted Hirao Reaction (General Methodology)
 - Title: A "green" variation of the Hirao reaction: the P–C coupling... under microwave and solvent-free conditions.[7]
 - Source: RSC Advances / Royal Society of Chemistry.
 - URL:[[Link](#)]
- Synthesis of Brigatinib Intermediates (Relevant Chemistry)
 - Title: Investigation into the Formation of Impurities during the Optimization of Brig
 - Source: ACS Omega (NIH/PMC).
 - URL:[[Link](#)]
- Safety Data for Dimethylphosphine Oxide
 - Title: Dimethylphosphine oxide Safety Data Sheet.[2][5][8]
 - Source: BLD Pharmatech.[5]
- Microwave P-C Coupling Reviews
 - Title: Microwave-assisted Hirao reaction: recent developments.[1]
 - Source: ResearchGate (Springer).[1]
 - URL:[[Link](#)]

Need Custom Synthesis?

BenchChem offers custom synthesis for rare earth carbides and specific isotopic labeling.

Email: info@benchchem.com or [Request Quote Online](#).

Sources

- [1. researchgate.net \[researchgate.net\]](#)
- [2. static.cymitquimica.com \[static.cymitquimica.com\]](#)
- [3. angenechemical.com \[angenechemical.com\]](#)
- [4. CAS 7211-39-4: Phosphine oxide, dimethyl- | CymitQuimica \[cymitquimica.com\]](#)
- [5. file.bldpharm.com \[file.bldpharm.com\]](#)
- [6. sciforum.net \[sciforum.net\]](#)
- [7. A “green” variation of the Hirao reaction: the P–C coupling of diethyl phosphite, alkyl phenyl-H-phosphinates and secondary phosphine oxides with bromoarenes using a P-ligand-free Pd\(OAc\)₂ catalyst under microwave and solvent-free conditions - RSC Advances \(RSC Publishing\) \[pubs.rsc.org\]](#)
- [8. synquestlabs.com \[synquestlabs.com\]](#)
- [To cite this document: BenchChem. \[Application Note: Microwave-Assisted Synthesis of 4-\(dimethylphosphoryl\)-2-methoxyaniline\]. BenchChem, \[2026\]. \[Online PDF\]. Available at: \[https://www.benchchem.com/product/b6232982/docs#application-note-microwave-assisted-synthesis-of-4-dimethylphosphoryl-2-methoxyaniline\]](#)

Disclaimer & Data Validity:

The information provided in this document is for Research Use Only (RUO) and is strictly not intended for diagnostic or therapeutic procedures. While BenchChem strives to provide accurate protocols, we make no warranties, express or implied, regarding the fitness of this product for every specific experimental setup.

Technical Support: The protocols provided are for reference purposes. Unsure if this reagent suits your experiment?

Need Industrial/Bulk Grade? [Request Custom Synthesis Quote](#)

BenchChem

Our mission is to be the trusted global source of essential and advanced chemicals, empowering scientists and researchers to drive progress in science and industry.

Contact

Address: 3281 E Guasti Rd

Ontario, CA 91761, United States

Phone: (601) 213-4426

Email: info@benchchem.com

[Contact our Ph.D. Support Team for a compatibility check](#)