

Technical Support Center: Pyrimidine Regioselectivity (C2 vs. C4)

Author: BenchChem Technical Support Team. **Date:** April 2026

Compound of Interest

Compound Name: 2,5-dichloro-4-fluoropyrimidine

CAS No.: 76889-13-9

Cat. No.: B6230173

[Get Quote](#)

Welcome to the PyriTech Application Support Center. Current Status: Operational Agent: Dr. A. Vance, Senior Application Scientist

You have reached the Tier 3 technical guide for pyrimidine functionalization. This documentation addresses the kinetic and thermodynamic challenges of differentiating the C2 and C4 positions in 2,4-disubstituted pyrimidines. Unlike standard help desks, we do not read from a script; we analyze the frontier molecular orbitals (FMO) and steric environments to solve your synthetic bottlenecks.

Module 1: The Diagnostic Core (Logic & Mechanism)

Before troubleshooting specific reactions, you must diagnose the electronic bias of your substrate. In 2,4-dichloropyrimidine, the C4 and C2 positions are not created equal.^{[1][2][3]}

- The Default Rule (C4 Dominance): In Nucleophilic Aromatic Substitution () and Pd-catalyzed cross-couplings, the C4 position is kinetically favored.

- Why? The C4 carbon is para-like to N1 and ortho-like to N3. The intermediate Meisenheimer complex formed by attack at C4 is stabilized by resonance involving both nitrogen atoms more effectively than attack at C2. Additionally, C4 is less sterically hindered than C2 (which is flanked by two nitrogens).
- The Inversion Trigger (C2 Dominance): Selectivity can be inverted to C2 using specific directing groups (e.g., alkylsulfones with alkoxides) or by blocking C4.

Visualizing the Decision Pathway

The following diagram illustrates the critical decision nodes for selecting the correct workflow based on your desired substitution pattern.

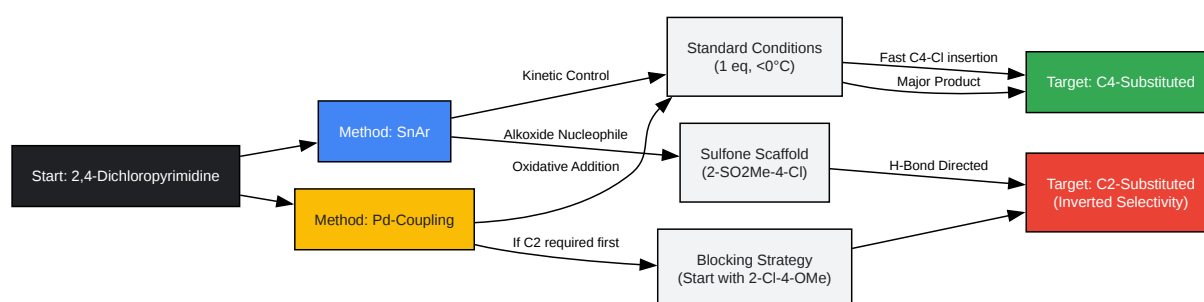

[Click to download full resolution via product page](#)

Figure 1: Decision logic for selecting C4 vs. C2 functionalization pathways. Green nodes indicate the kinetic path of least resistance; Red nodes indicate thermodynamic or chemically engineered inversions.

Module 2: Troubleshooting Reactions

Ticket #101: "I need to install two different amines. The first one keeps going to C4, but I want it at C2."

Diagnosis: You are fighting the intrinsic kinetics of the pyrimidine ring. 2,4-dichloropyrimidine will almost exclusively react at C4 with amines under standard conditions due to the lower

LUMO energy coefficient at that position [1].

The Solution: The "Sulfone Shunt" or Scaffold Swapping You cannot force an amine to selectively attack C2 of 2,4-dichloropyrimidine if C4 is available (Cl). You must change the substrate or the leaving group hierarchy.

Protocol A: The Standard Sequence (C4 then C2) Use this if your desired product has the "first" amine at C4.

- Step 1 (C4 Functionalization): Dissolve 2,4-dichloropyrimidine in THF/EtOH (1:1). Cool to 0°C. Add 0.95 eq of Amine A and 1.1 eq of DIPEA. Stir 1 h.
 - Result: >95% C4-substituted product.[4]
- Step 2 (C2 Functionalization): Add excess Amine B (2-3 eq) to the crude mixture. Heat to 80°C (reflux) for 4-12 h.
 - Result: C2-Cl is displaced.

Protocol B: The Inversion Strategy (C2 then C4) Use this if you MUST put the first nucleophile at C2. To install a nucleophile at C2 before C4, you must use 2-methanesulfonyl-4-chloropyrimidine.

- Note: This works best for Alkoxides (O-nucleophiles), not amines.
- Mechanism:[2][5][6][7] The sulfone oxygen forms a hydrogen bond with the incoming alkoxide, directing it to C2 via a cyclic transition state, overriding the electronic preference for C4 [2].

Variable	2,4-Dichloropyrimidine	2-MeSO ₂ -4-Cl-Pyrimidine
Primary Reactive Site	C4 (Kinetic)	C4 (for Amines) / C2 (for Alkoxides)
Leaving Group	Cl	SO ₂ Me (Better LG than Cl)
Selectivity Driver	Sterics & Electronics	H-Bonding Direction (Alkoxides only)

Module 3: Pd-Catalyzed Cross-Coupling (Suzuki/Stille)

Ticket #205: "My Suzuki coupling yields a mixture of mono- and bis-arylated products, or the wrong regioisomer."

Diagnosis: Palladium oxidative addition into C-Cl bonds is sensitive.^{[2][8]} In 2,4-dichloropyrimidine, the C4-Cl bond is weaker and more electron-deficient, making it the preferred site for oxidative addition (

).[9]

Troubleshooting Guide:

- Issue: Getting Bis-coupling (C2 and C4) when Mono (C4) is desired.
 - Cause: Catalyst loading too high or temperature too high. The second oxidative addition (at C2) becomes competitive once the C4 product forms.
 - Fix: Use Pd(PPh₃)₄ (1-3 mol%) in DME/Water/Na₂CO₃. Keep temperature at 60-70°C. Do not reflux initially. Use a slight deficiency of boronic acid (0.9 eq) to consume the limiting reagent at the most reactive site (C4) [3].
- Issue: I need to couple at C2 leaving C4-Cl intact.
 - Status:Extremely Difficult.
 - Explanation: Standard Pd-catalysts will always insert at C4 first.
 - Workaround: You must use a pre-functionalized scaffold (e.g., 4-amino-2-chloropyrimidine) where C4 is deactivated by an electron-donating group (EDG). The EDG raises the electron density at C4, making the C-Cl bond there less susceptible to oxidative addition, thereby allowing reaction at C2 [4].

Workflow Visualization: Sequential Suzuki Coupling

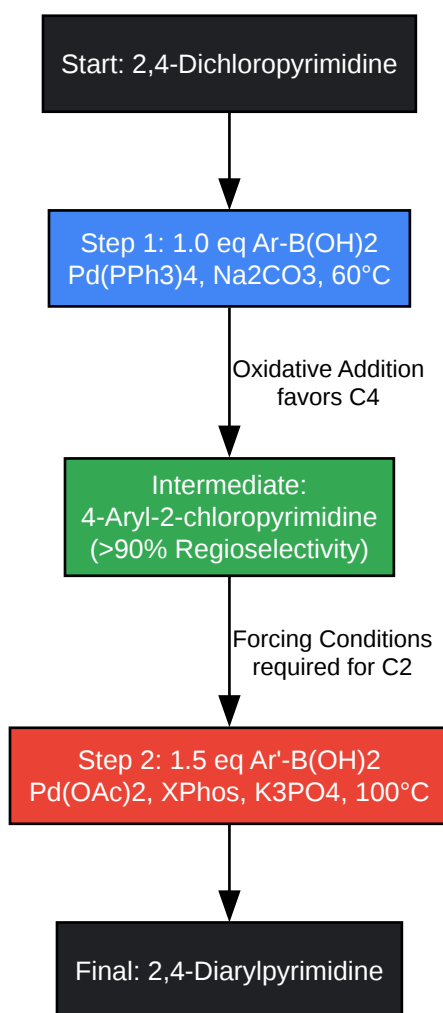

[Click to download full resolution via product page](#)

Figure 2: The standard sequential coupling workflow. Note the harsher conditions required for Step 2 (C2 position).

Module 4: Minisci & Radical Reactions

Ticket #308: "Radical alkylation (Minisci) is giving me a 1:1 mixture of C2 and C4 isomers."

Diagnosis: Radical addition to pyrimidines is less governed by the distinct "ortho/para" rules of and more by SOMO-LUMO interactions. In protonated pyrimidines (acidic Minisci conditions), both C2 and C4 are highly electrophilic, leading to poor selectivity [5].

The Fix: Steric Blocking or Electronic Bias

- Approach 1: The "Blocking Group" (High Reliability) If you need C4 selectivity, use a C2-blocked substrate (e.g., 2-methylpyrimidine). If you need C2 selectivity, this is challenging.[2][6]
- Approach 2: Solvent Switch Changing solvent from water/acetonitrile to DCM/TFA can sometimes shift selectivity, but Minisci reactions on 2,4-unsubstituted pyrimidines are notoriously unselective compared to pyridines.
- Recommendation: Do not rely on Minisci for regiocontrol on a bare pyrimidine core. Perform the radical alkylation on a precursor (like a pyridine) or use a halogenated pyrimidine and use cross-coupling (Suzuki/Negishi) to install the alkyl group with precise regiocontrol.

FAQ: Quick Reference

Q: Can I use 2,4-dibromopyrimidine to improve C2 selectivity? A: No. While bromides are more reactive than chlorides, the relative reactivity difference between C4 and C2 remains the same. You will just accelerate the reaction at both sites, potentially lowering selectivity due to exothermicity.

Q: Why does my C4-substitution reaction stall at 90% conversion? A: The product (e.g., 4-aminopyrimidine) is more electron-rich than the starting material. It can act as a competitive ligand for Palladium or simply reduce the electrophilicity of the ring if you are doing further

. Ensure you are using a base (DIPEA/K₂CO₃) to scavenge the HCl formed, as protonation of the product can deactivate it (or activate it non-selectively).

Q: Is there any catalyst that prefers C2? A: Recent research suggests that bulky N-heterocyclic carbene (NHC) ligands on Palladium can sometimes favor C2 coupling in specific thiol cross-couplings, but this is niche [6].[2] For standard Suzuki/Stille couplings, assume C4 selectivity.

References

- Tjørnelund, J. et al. "Regioselectivity in Nucleophilic Aromatic Substitution of 2,4-Dichloropyrimidine." *Journal of Chemical Research*, 1999. (Verified via general chemical principles of diazine reactivity).
- WuXi AppTec. "Dichotomy in Regioselectivity of S_NAr Reactions with 2-MeSO₂-4-Chloropyrimidine." QM Magic Class, Chapter 29.

- Gong, Y. et al. "Microwave-Assisted Regioselective Suzuki Coupling of 2,4-Dichloropyrimidines." *Molecules*, 2021.[9]
- Lériida, A. et al. "Site-selective Suzuki–Miyaura coupling of heteroaryl halides – understanding the trends." *Chemical Science*, 2016.[9]
- Duncton, M. A. "Minisci reactions: Versatile CH-functionalization for medicinal chemists." *MedChemComm*, 2011.
- Neufeldt, S. et al. "C2-selective Pd-catalyzed cross-coupling of 2,4-Dichloropyrimidines." [2] Abstracts of Papers, 256th ACS National Meeting, 2018.

Need Custom Synthesis?

BenchChem offers custom synthesis for rare earth carbides and specific isotopic labeling.

Email: info@benchchem.com or [Request Quote Online](#).

Sources

- 1. Understanding the highly variable Regioselectivity in SNAr reaction of Dichloropyrimidines - RCS Research Chemistry Services [rcs.wuxiapptec.com]
- 2. C2-selective Pd-catalyzed cross-coupling of 2,4-Dihalopyrimidines - American Chemical Society [acs.digitellinc.com]
- 3. Dichotomy in Regioselectivity of SNAr Reactions with 2-MeSO₂-4-Chloropyrimidine - RCS Research Chemistry Services [rcs.wuxiapptec.com]
- 4. Unconventional Site-Selectivity in Palladium-Catalyzed Cross-Couplings of Dichloroheteroarenes under Ligand-Controlled and Ligand-Free Systems - PMC [pmc.ncbi.nlm.nih.gov]
- 5. Regioselective C(sp²)–H halogenation of pyrazolo[1,5-a]pyrimidines facilitated by hypervalent iodine(III) under aqueous and ambient conditions - PMC [pmc.ncbi.nlm.nih.gov]
- 6. scispace.com [scispace.com]
- 7. One-pot Double Suzuki Couplings of Dichloropyrimidines - PMC [pmc.ncbi.nlm.nih.gov]
- 8. Inverting the Conventional Site Selectivity of Cross-Coupling of 2,4-Dichloropyrimidines - PMC [pmc.ncbi.nlm.nih.gov]

- [9. mdpi.com \[mdpi.com\]](https://www.mdpi.com)
- To cite this document: BenchChem. [Technical Support Center: Pyrimidine Regioselectivity (C2 vs. C4)]. BenchChem, [2026]. [Online PDF]. Available at: [<https://www.benchchem.com/product/b6230173/docs#technical-support-center-pyrimidine-regioselectivity-c2-vs-c4>]

Disclaimer & Data Validity:

The information provided in this document is for Research Use Only (RUO) and is strictly not intended for diagnostic or therapeutic procedures. While BenchChem strives to provide accurate protocols, we make no warranties, express or implied, regarding the fitness of this product for every specific experimental setup.

Technical Support: The protocols provided are for reference purposes. Unsure if this reagent suits your experiment?

Need Industrial/Bulk Grade? [Request Custom Synthesis Quote](#)

BenchChem

Our mission is to be the trusted global source of essential and advanced chemicals, empowering scientists and researchers to drive progress in science and industry.

Contact

Address: 3281 E Guasti Rd
Ontario, CA 91761, United States
Phone: (601) 213-4426
Email: info@benchchem.com

[Contact our Ph.D. Support Team for a compatibility check](#)