

BCN-OH in Bioconjugation: A Technical Guide

Author: BenchChem Technical Support Team. **Date:** April 2026

Compound of Interest

Compound Name:	BCN-OH
CAS No.:	1263291-41-3
Cat. No.:	B6226234

[Get Quote](#)

For Researchers, Scientists, and Drug Development Professionals

Introduction

Bicyclo[6.1.0]non-4-yn-9-ylmethanol (**BCN-OH**) has emerged as a pivotal tool in the field of bioconjugation, offering a unique combination of reactivity, stability, and biocompatibility. As a strained alkyne, **BCN-OH** is a key player in copper-free click chemistry, most notably in Strain-Promoted Azide-Alkyne Cycloaddition (SPAAC) reactions. This technical guide provides an in-depth exploration of **BCN-OH**'s applications, supported by quantitative data, detailed experimental protocols, and workflow visualizations to empower researchers in their bioconjugation endeavors.

The primary advantage of **BCN-OH** lies in its ability to react selectively with azides under physiological conditions without the need for a cytotoxic copper catalyst, making it ideal for applications involving live cells and sensitive biomolecules.[1][2] The terminal hydroxyl group of **BCN-OH** serves as a versatile chemical handle, allowing for its derivatization and incorporation into a wide array of molecules and materials.[3]

Core Applications of BCN-OH in Bioconjugation

The versatility of **BCN-OH** has led to its widespread adoption in numerous bioconjugation applications:

- **Biomolecule Labeling:** **BCN-OH** and its derivatives are extensively used for the specific labeling of proteins, peptides, nucleic acids, and carbohydrates that have been modified to contain an azide group.[4][5] This enables the attachment of various tags, such as fluorophores for imaging, biotin for affinity purification, or polyethylene glycol (PEG) for improved solubility and pharmacokinetics.[4]
- **Drug Delivery and Antibody-Drug Conjugates (ADCs):** In the realm of therapeutic development, **BCN-OH** serves as a critical linker for constructing ADCs.[3][6] The stable triazole linkage formed via SPAAC ensures that the cytotoxic payload remains attached to the antibody until it reaches the target cell, minimizing off-target toxicity.[3]
- **Nanoparticle and Surface Functionalization:** The ability to modify surfaces with **BCN-OH** allows for the subsequent attachment of azide-containing molecules. This has been applied to nanoparticles, liposomes, and other materials to create targeted drug delivery systems and advanced biosensors.[7]
- **Chemical Biology and Cellular Imaging:** **BCN-OH** facilitates the investigation of biological processes in living systems. By metabolically incorporating azide-functionalized building blocks into biomolecules, researchers can use BCN-functionalized probes to visualize and track these molecules in real-time.[8][9]

Quantitative Data on BCN Reactions

The efficiency and kinetics of SPAAC reactions are critical for successful bioconjugation. The following table summarizes key quantitative data for BCN reactions.

Reactants	Reaction Type	Second-Order Rate Constant (k_2) ($M^{-1}s^{-1}$)	Solvent/Conditions	Reference(s)
endo-BCN + Benzyl Azide	SPAAC	0.29	CD ₃ CN/D ₂ O (1:2)	[5]
exo-BCN + Benzyl Azide	SPAAC	0.19	CD ₃ CN/D ₂ O (1:2)	[5]
BCN-OH + Benzyl Azide	SPAAC	0.14	CD ₃ CN/D ₂ O (3:1)	[2]
BCN-Acid + Benzyl Azide	SPAAC	0.20	Acetonitrile/Water (1:2)	[10]
BCN-DY549 + Azido-protein	SPAAC	0.48	In the presence of 14 mM β-mercaptoethanol	[2]
BCN + Tetrazine	iEDDA	Rapid (quantitative in 30 min)	Room Temperature	[10]

Note: The reactivity of BCN can be influenced by the specific isomer (endo or exo), the nature of the azide (alkyl or aryl), and the reaction conditions. The endo-isomer is generally more reactive in SPAAC.[5]

Experimental Protocols

Protocol 1: General Procedure for Protein Labeling using BCN-NHS Ester

This protocol outlines the steps for labeling an azide-modified protein with a BCN-NHS ester.

Materials:

- Azide-modified protein in an amine-free buffer (e.g., PBS, pH 7.4)
- BCN-NHS ester dissolved in anhydrous DMSO (e.g., 10 mM stock solution)

- Quenching solution (e.g., 1 M Tris-HCl, pH 8.0)
- Purification system (e.g., size-exclusion chromatography or dialysis)

Methodology:

- Protein Preparation: Ensure the azide-modified protein is purified and buffer-exchanged into an amine-free buffer. Determine the protein concentration accurately.
- Activation of BCN: Immediately before use, dissolve the BCN-NHS ester in anhydrous DMSO to the desired stock concentration.
- Conjugation Reaction:
 - Add a 10-20 fold molar excess of the BCN-NHS ester solution to the protein solution. The final DMSO concentration should be kept below 10% (v/v) to maintain protein integrity.
 - Incubate the reaction mixture for 1-2 hours at room temperature or overnight at 4°C with gentle mixing.
- Quenching: Add a small volume of the quenching solution (e.g., to a final concentration of 50 mM) to react with any unreacted BCN-NHS ester. Incubate for 15-30 minutes at room temperature.
- Purification: Remove excess BCN reagent and byproducts by size-exclusion chromatography, dialysis, or spin filtration.
- Characterization: Analyze the conjugate by SDS-PAGE to observe a band shift, and determine the degree of labeling by mass spectrometry.

Protocol 2: Oligonucleotide Conjugation via SPAAC

This protocol describes the conjugation of a BCN-modified oligonucleotide to an azide-containing molecule.

Materials:

- BCN-modified oligonucleotide

- Azide-containing molecule (e.g., fluorescent dye, peptide)
- Reaction buffer (e.g., PBS, pH 7.4, or a mixture of water and a water-miscible organic solvent like DMSO or ethanol)[1]
- Purification system (e.g., HPLC)

Methodology:

- Reagent Preparation: Dissolve the BCN-modified oligonucleotide and the azide-containing molecule in the reaction buffer.
- Conjugation Reaction:
 - Mix the BCN-oligonucleotide and the azide-containing molecule in the desired molar ratio (a slight excess of one reagent may be used to drive the reaction to completion).
 - Incubate the reaction at room temperature. Reaction times can vary from a few hours to overnight, depending on the reactivity of the components.[11]
- Monitoring the Reaction: The progress of the reaction can be monitored by HPLC or LC-MS.
- Purification: Purify the oligonucleotide conjugate using reverse-phase HPLC to separate the conjugate from unreacted starting materials.[12]
- Characterization: Confirm the identity and purity of the conjugate by mass spectrometry and UV-Vis spectroscopy.

Mandatory Visualizations

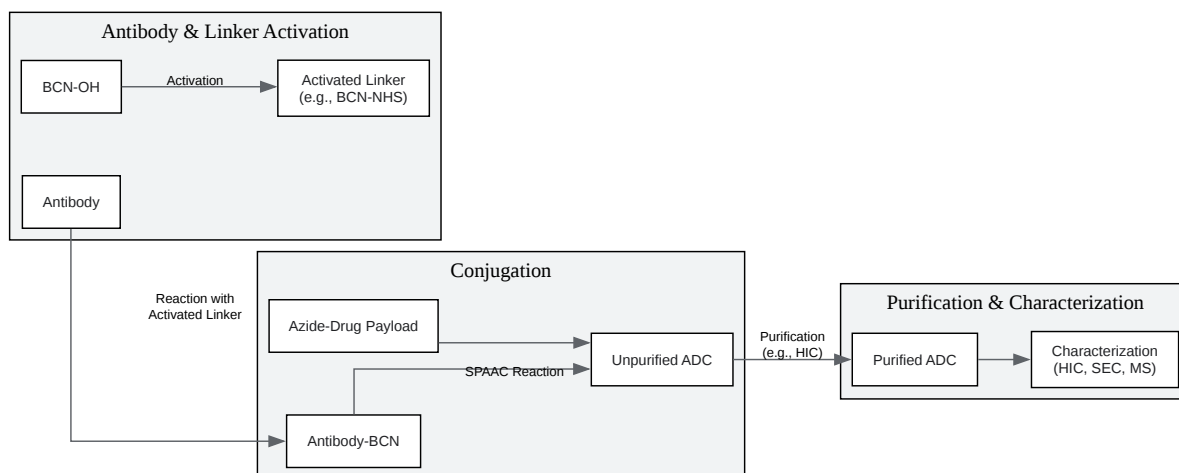

[Click to download full resolution via product page](#)

Caption: Workflow for Antibody-Drug Conjugate (ADC) Synthesis using **BCN-OH**.

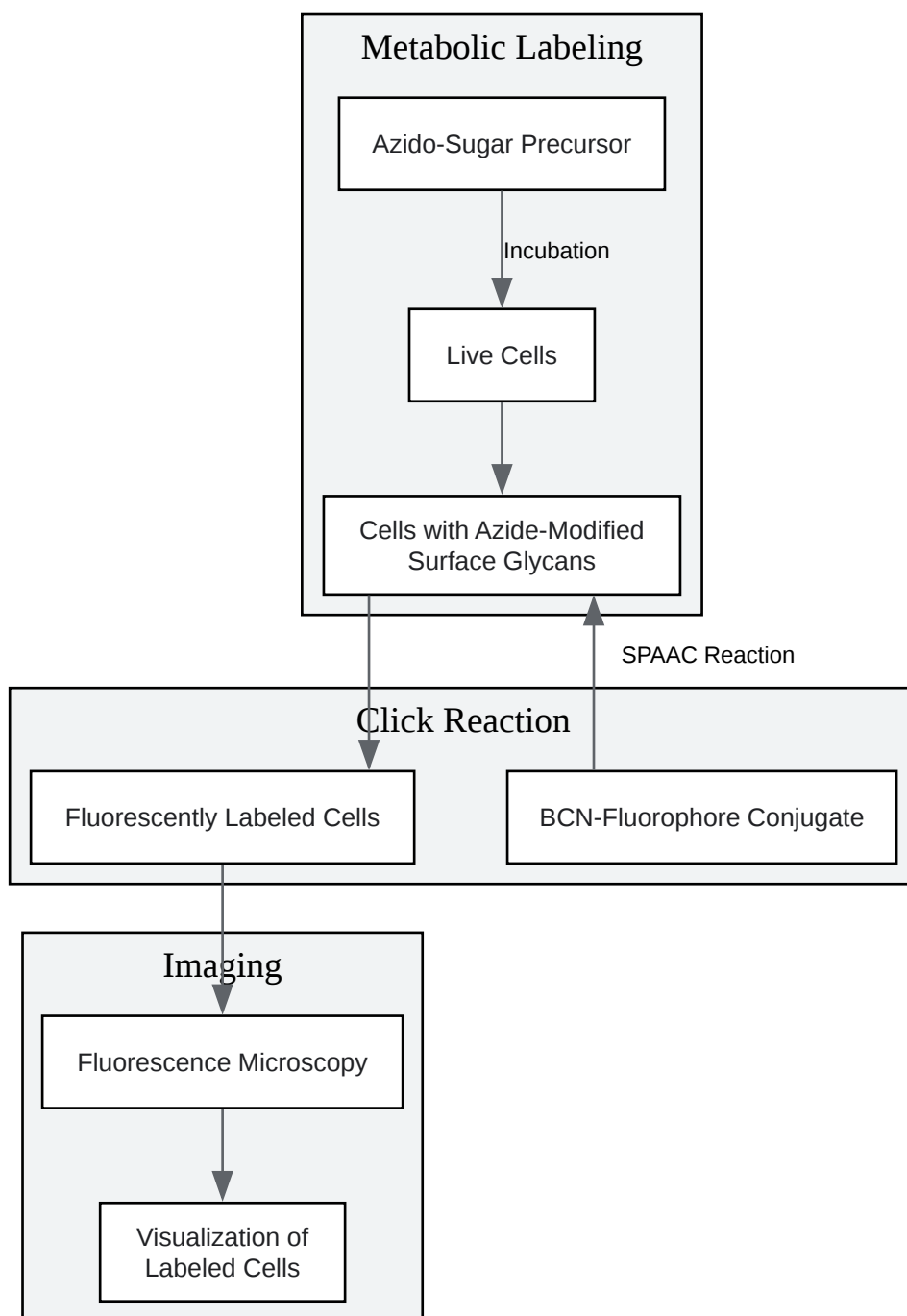

[Click to download full resolution via product page](#)

Caption: Workflow for Live Cell Surface Labeling and Imaging.

Stability Considerations

The stability of the resulting conjugate is crucial for its intended application. The triazole ring formed through SPAAC is generally very stable under a wide range of physiological conditions, including resistance to hydrolysis and enzymatic degradation.[13] However, the linkage used to attach **BCN-OH** to a biomolecule can impact the overall stability. For instance, amide bonds are significantly more stable in biological media compared to carbamate linkages, which can be prone to hydrolysis.[10] When designing BCN-based probes for long-term studies, utilizing an amide linkage is recommended for enhanced stability.[14]

Conclusion

BCN-OH is a powerful and versatile reagent that has significantly advanced the field of bioconjugation. Its high reactivity in copper-free click chemistry, coupled with the versatility of its hydroxyl group for derivatization, makes it an invaluable tool for researchers across various disciplines. By understanding the principles of its reactivity, leveraging detailed experimental protocols, and considering the stability of the resulting conjugates, scientists and drug development professionals can effectively harness the potential of **BCN-OH** to create novel bioconjugates for a wide range of applications, from fundamental biological research to the development of next-generation therapeutics.

Need Custom Synthesis?

BenchChem offers custom synthesis for rare earth carbides and specific isotopic labeling.

Email: info@benchchem.com or [Request Quote Online](#).

References

- [1. broadpharm.com \[broadpharm.com\]](#)
- [2. A Simple Method for Enhancing the Bioorthogonality of Cyclooctyne Reagent - PMC \[pmc.ncbi.nlm.nih.gov\]](#)
- [3. journal.unnes.ac.id \[journal.unnes.ac.id\]](#)
- [4. What is BCN : A Versatile Bioconjugation Tool | AxisPharm \[axispharm.com\]](#)
- [5. Manipulating Diastereomeric Bicyclononynes to Sensitive Determine Enzyme Activity and Facilitate Macromolecule Conjugations - PMC \[pmc.ncbi.nlm.nih.gov\]](#)
- [6. journal.unnes.ac.id \[journal.unnes.ac.id\]](#)

- [7. Labeling proteins on live mammalian cells using click chemistry | Springer Nature Experiments \[experiments.springernature.com\]](#)
- [8. Imaging Cell Surface Glycosylation in Vivo Using “Double Click” Chemistry - PMC \[pmc.ncbi.nlm.nih.gov\]](#)
- [9. Labeling proteins on live mammalian cells using click chemistry - PubMed \[pubmed.ncbi.nlm.nih.gov\]](#)
- [10. Bicyclo\[6.1.0\]nonyne carboxylic acid for the production of stable molecular probes - PMC \[pmc.ncbi.nlm.nih.gov\]](#)
- [11. BCN Endo 5' \(Bicyclononyne\) 5' Oligo Modifications from Gene Link \[genelink.com\]](#)
- [12. How do you purify oligonucleotide conjugates by HPLC? | AAT Bioquest \[aatbio.com\]](#)
- [13. benchchem.com \[benchchem.com\]](#)
- [14. Synthesis and stability studies of bicyclo\[6.1.0\]nonyne scaffolds for automated solid-phase oligonucleotide synthesis - PMC \[pmc.ncbi.nlm.nih.gov\]](#)
- To cite this document: BenchChem. [BCN-OH in Bioconjugation: A Technical Guide]. BenchChem, [2026]. [Online PDF]. Available at: [\[https://www.benchchem.com/product/b6226234/docs#bcn-oh-in-bioconjugation-a-technical-guide\]](https://www.benchchem.com/product/b6226234/docs#bcn-oh-in-bioconjugation-a-technical-guide)

Disclaimer & Data Validity:

The information provided in this document is for Research Use Only (RUO) and is strictly not intended for diagnostic or therapeutic procedures. While BenchChem strives to provide accurate protocols, we make no warranties, express or implied, regarding the fitness of this product for every specific experimental setup.

Technical Support: The protocols provided are for reference purposes. Unsure if this reagent suits your experiment?

Need Industrial/Bulk Grade? [Request Custom Synthesis Quote](#)

BenchChem

Our mission is to be the trusted global source of essential and advanced chemicals, empowering scientists and researchers to drive progress in science and industry.

Contact

Address: 3281 E Guasti Rd

Ontario, CA 91761, United States

Phone: (601) 213-4426

Email: info@benchchem.com

[Contact our Ph.D. Support Team for a compatibility check](#)