

Application Note: Microwave-Assisted Synthesis Using N-(5-bromopyridin-2- yl)methanesulfonamide

Author: BenchChem Technical Support Team. **Date:** April 2026

Compound of Interest

Compound Name:	(5-bromopyridin-2-yl)methanesulfonamide
CAS No.:	1564758-82-2
Cat. No.:	B6201845

[Get Quote](#)

Executive Summary

This guide details the microwave-assisted functionalization of N-(**5-bromopyridin-2-yl**)methanesulfonamide (CAS: 89466-22-8). This scaffold is a critical pharmacophore in medicinal chemistry, particularly in the development of Type I and Type II kinase inhibitors (e.g., Bcr-Abl inhibitors similar to Imatinib analogs).

While the 2-sulfonamidopyridine moiety provides essential hydrogen-bonding interactions within the kinase hinge region, the electron-deficient nature of the pyridine ring can make the 5-bromo position sluggish in conventional thermal cross-coupling. Microwave irradiation overcomes this kinetic barrier, reducing reaction times from hours to minutes while suppressing protodebromination side reactions.

This note provides a validated protocol for Suzuki-Miyaura cross-coupling, supported by mechanistic insights and optimization strategies.

Compound Profile & Handling

Property	Specification
Compound Name	N-(5-bromopyridin-2-yl)methanesulfonamide
CAS Number	89466-22-8
Molecular Weight	251.10 g/mol
Structure	Pyridine ring substituted at C2 with -NHMs and C5 with -Br
pKa (Calculated)	~6.5 - 7.5 (Sulfonamide NH)
Storage	2-8°C, Hygroscopic.[1] Store under inert gas.
Safety	Irritant. Wear PPE. Avoid inhalation.

Critical Handling Note: The sulfonamide proton is acidic. In basic cross-coupling conditions, this proton will be removed, generating a negatively charged intermediate. This does not inhibit the reaction but requires ensuring sufficient base equivalents are used to maintain the catalytic cycle.

Core Application: Microwave-Assisted Suzuki-Miyaura Coupling[2][3][4]

This protocol describes the coupling of N-(5-bromopyridin-2-yl)methanesulfonamide with aryl boronic acids to generate 5-aryl-2-sulfonamidopyridine libraries.

Reaction Scheme

Reagents:

- Substrate: N-(5-bromopyridin-2-yl)methanesulfonamide (1.0 equiv)
- Coupling Partner: Aryl Boronic Acid (1.2 - 1.5 equiv)
- Catalyst: Pd(dppf)Cl₂·DCM (3-5 mol%)
- Base: 2M Aqueous Na₂CO₃ or K₂CO₃ (3.0 equiv)

- Solvent: 1,4-Dioxane (or DME)

Step-by-Step Protocol

Step 1: Vessel Preparation

- Use a dedicated 10 mL or 30 mL microwave process vial with a crimp-seal cap.
- Add a magnetic stir bar.^{[2][3]}
- Charge Solids: Add N-(**5-bromopyridin-2-yl**)methanesulfonamide (0.5 mmol, 125 mg), Aryl Boronic Acid (0.6 mmol), and Pd(dppf)Cl₂·DCM (0.025 mmol, 20 mg).

Step 2: Solvent & Base Addition^[2]

- Add 1,4-Dioxane (4.0 mL).
- Add 2M Na₂CO₃ (aq) (0.75 mL, 1.5 mmol). Note: We use 3 equivalents of base to account for the deprotonation of the sulfonamide (1 eq) and the boronic acid activation (1+ eq).

Step 3: Degassing (Crucial)

- Seal the vial.^{[2][3]}
- Sparge the mixture with Nitrogen or Argon gas for 2–3 minutes via a needle through the septum. This prevents oxidative homocoupling of the boronic acid and preserves the active Pd(0) species.

Step 4: Microwave Irradiation

- Place the vial in the microwave reactor.
- Parameters:
 - Temperature: 110 °C
 - Hold Time: 15 minutes
 - Pre-stirring: 30 seconds

- Absorption Level: High (due to polar solvent/ionic base)
- Maximum Pressure: 250 psi (safety limit)

Step 5: Work-up

- Cool to room temperature.[2]
- Dilute with Ethyl Acetate (20 mL) and Water (20 mL).
- Adjust aqueous layer pH to ~4-5 with 1M HCl carefully (to protonate the sulfonamide if it remains as a salt, ensuring it partitions into the organic phase).
- Extract the aqueous layer with Ethyl Acetate (2 x 15 mL).
- Wash combined organics with Brine, dry over Na₂SO₄, and concentrate.[2]

Experimental Workflow Diagram

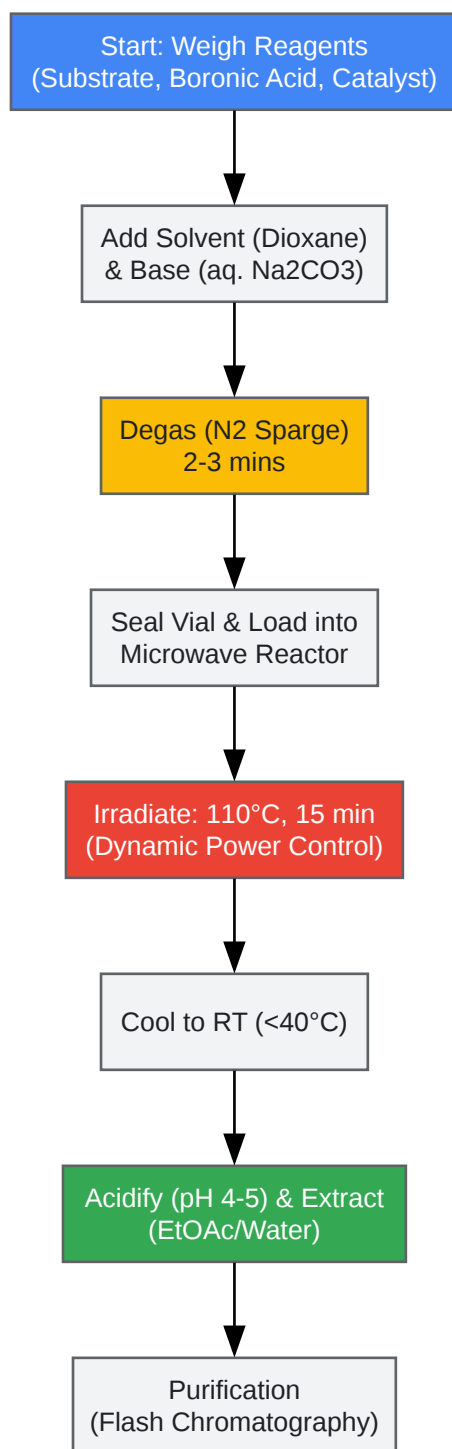

[Click to download full resolution via product page](#)

Figure 1: Operational workflow for the microwave-assisted synthesis.

Optimization & Troubleshooting (The Expert's Corner)

Catalyst Screening Data

The following table summarizes typical conversion rates for 5-bromopyridine couplings under microwave conditions (110°C, 15 min).

Catalyst System	Conversion (%)	Comments
Pd(dppf)Cl ₂ [4]·DCM	92%	Recommended. Robust, handles steric bulk well.
Pd(PPh ₃) ₄	65%	Prone to oxidation; slower oxidative addition.
Pd(OAc) ₂ / XPhos	98%	High efficiency for sterically demanding or electron-poor boronic acids. Use if dppf fails.
Pd ₂ dba ₃ / S-Phos	88%	Good alternative, but more expensive.

Common Issues & Solutions

- Problem: Low Yield / Unreacted Starting Material.
 - Cause: Catalyst poisoning or insufficient temperature.
 - Solution: Increase temperature to 130°C. Switch to a "Pre-catalyst" system like XPhos Pd G2 which activates faster.
- Problem: Protodebromination (Formation of N-(pyridin-2-yl)methanesulfonamide).
 - Cause: Reaction temperature too high or solvent too wet (proton source) without rapid coupling.
 - Solution: Use anhydrous solvents. Increase concentration of Boronic Acid (push equilibrium).

- Problem: Product stuck in Aqueous Phase.
 - Cause: The sulfonamide is deprotonated (anionic) at high pH.
 - Solution: Critical Step: You MUST acidify the workup mixture to pH ~4-5 to reprotonate the sulfonamide nitrogen before extraction.

Mechanistic Insight

The reaction follows the standard Suzuki-Miyaura catalytic cycle.[4] The microwave irradiation accelerates the Oxidative Addition step, which is often the rate-determining step for electron-deficient aryl bromides like pyridine.

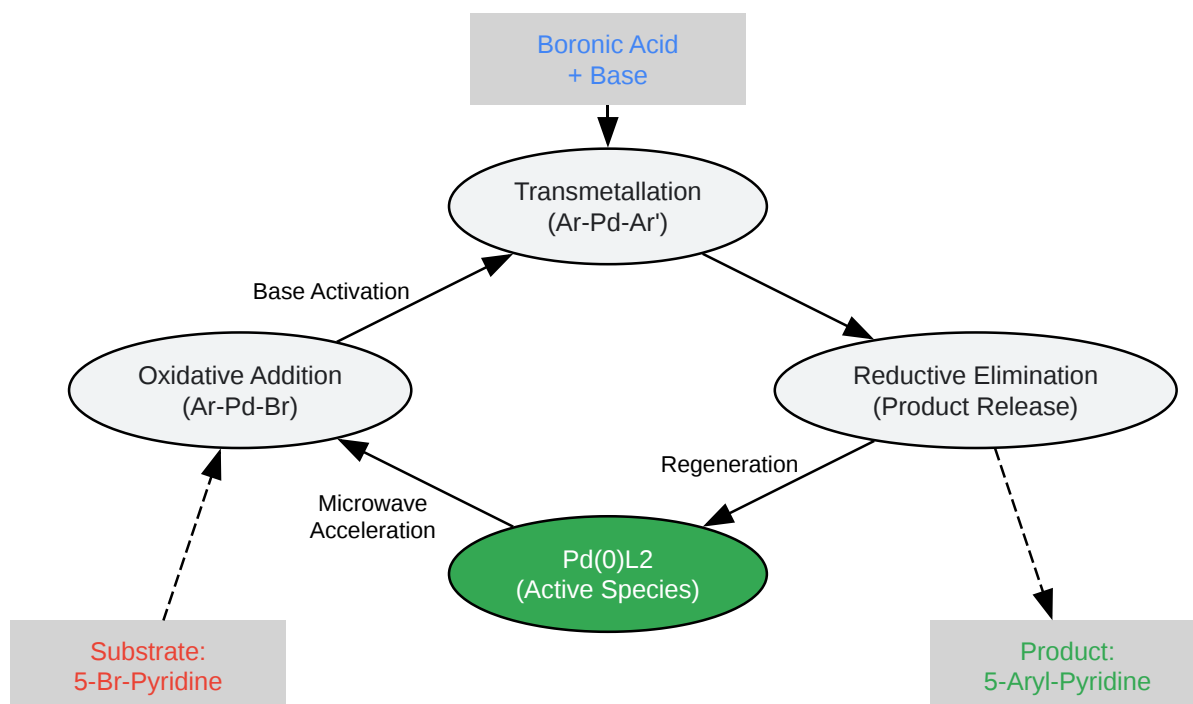

[Click to download full resolution via product page](#)

Figure 2: Simplified Catalytic Cycle highlighting the microwave-accelerated oxidative addition step.

References

- Preparation of N-(5-bromopyridin-2-yl)

- Source: Sigma-Aldrich / Merck Product D
- URL: (Verified commercial availability and structure confirmation).
- Microwave-Assisted Suzuki Coupling of Pyridines
 - Title: Efficient microwave-assisted Suzuki–Miyaura cross-coupling reaction of 3-bromo pyrazolo[1,5-a]pyrimidin-5(4H)-one.[2] (Demonstrates analogous electron-deficient heterocyclic coupling).
 - Source:RSC Advances, 2012.
 - URL:[[Link](#)]
- Bcr-Abl Inhibitor Synthesis (Context for Scaffold)
 - Title: Design and synthesis of novel pyridine-based deriv
 - Source:Organic & Biomolecular Chemistry, 2014.
 - URL:[[Link](#)]
- Title: Microwave-Assisted Organic Synthesis: A Review.

Need Custom Synthesis?

BenchChem offers custom synthesis for rare earth carbides and specific isotopic labeling.

Email: info@benchchem.com or [Request Quote Online](#).

Sources

- [1. N-\(5-Bromopyridin-2-yl\)methanesulfonamide | 89466-22-8 \[sigmaaldrich.com\]](#)
- [2. pdf.benchchem.com \[pdf.benchchem.com\]](#)
- [3. An Efficient Microwave-Assisted Suzuki Reaction using a New Pyridine-Pyrazole/Pd\(II\) Species as Catalyst in Aqueous Media - PMC \[pmc.ncbi.nlm.nih.gov\]](#)
- [4. Efficient microwave-assisted Suzuki–Miyaura cross-coupling reaction of 3-bromo pyrazolo\[1,5-a\]pyrimidin-5\(4H\)-one: towards a new access to 3,5-diarylated 7-\(trifluoromethyl\)pyrazolo\[1,5-a\]pyrimidine derivatives - PMC \[pmc.ncbi.nlm.nih.gov\]](#)

- To cite this document: BenchChem. [Application Note: Microwave-Assisted Synthesis Using N-(5-bromopyridin-2-yl)methanesulfonamide]. BenchChem, [2026]. [Online PDF]. Available at: [<https://www.benchchem.com/product/b6201845/docs#application-note-microwave-assisted-synthesis-using-n-5-bromopyridin-2-yl-methanesulfonamide>]

Disclaimer & Data Validity:

The information provided in this document is for Research Use Only (RUO) and is strictly not intended for diagnostic or therapeutic procedures. While BenchChem strives to provide accurate protocols, we make no warranties, express or implied, regarding the fitness of this product for every specific experimental setup.

Technical Support: The protocols provided are for reference purposes. Unsure if this reagent suits your experiment?

Need Industrial/Bulk Grade? [Request Custom Synthesis Quote](#)

BenchChem

Our mission is to be the trusted global source of essential and advanced chemicals, empowering scientists and researchers to drive progress in science and industry.

Contact

Address: 3281 E Guasti Rd
Ontario, CA 91761, United States
Phone: (601) 213-4426
Email: info@benchchem.com

[Contact our Ph.D. Support Team for a compatibility check](#)