

A Comparative Guide to the Mass Spectrometric Fragmentation of C₈H₉NO₃ Isomers

Author: BenchChem Technical Support Team. **Date:** April 2026

Compound of Interest

Compound Name: 3-[(hydroxyamino)methyl]benzoic acid
CAS No.: 1258540-35-0
Cat. No.: B6201953

[Get Quote](#)

For researchers, medicinal chemists, and drug development professionals, the unambiguous identification of isomeric compounds is a frequent and critical challenge. Molecules sharing the same elemental formula (C₈H₉NO₃ in this case) can possess vastly different chemical, pharmacological, and toxicological properties. Mass spectrometry (MS), a cornerstone of modern analytical chemistry, offers a powerful means to differentiate these isomers by exploiting their unique gas-phase fragmentation behaviors.

This guide provides an in-depth comparison of the mass spectrometric fragmentation patterns of three key C₈H₉NO₃ isomers: the widely used analgesic Paracetamol (Acetaminophen), and the positional isomers 2-Nitrophenetole, 3-Nitrophenetole, and 4-Nitrophenetole. We will explore the mechanistic underpinnings of their fragmentation in both Electron Ionization (EI) and Electrospray Ionization (ESI), providing field-proven insights to aid in their differentiation.

The Challenge of Isomer Differentiation

Isomers present a unique analytical hurdle as they possess the same nominal mass, making them indistinguishable by low-resolution mass spectrometry alone[1]. Differentiation, therefore,

relies on generating and detecting unique fragment ions, which serve as a structural fingerprint for each molecule[2]. The stability of the resulting fragment ions and the energetic favorability of different fragmentation pathways are dictated by the molecule's specific arrangement of atoms and functional groups.

This guide will dissect these differences, providing a framework for confident isomer identification.

Experimental Methodologies

To ensure reproducible and comparable data, standardized analytical protocols are paramount. Below are detailed step-by-step methodologies for Gas Chromatography-Mass Spectrometry (GC-MS) and Liquid Chromatography-Tandem Mass Spectrometry (LC-MS/MS) analysis of C₈H₉NO₃ isomers.

Sample Preparation

Proper sample preparation is crucial for high-quality mass spectrometric data, minimizing matrix effects and ensuring analyte stability[3][4].

- Standard Solution Preparation:
 - Accurately weigh approximately 10 mg of each isomer standard (Paracetamol, 2-Nitrophenetole, 3-Nitrophenetole, 4-Nitrophenetole).
 - Dissolve each standard in 10 mL of a suitable solvent (e.g., methanol or acetonitrile) to create a stock solution of 1 mg/mL[5].
 - Perform serial dilutions with the same solvent to achieve working concentrations appropriate for the instrument's sensitivity (typically in the range of 1-10 µg/mL for GC-MS and ng/mL to low µg/mL for LC-MS/MS)[5].
- Matrix Sample Preparation (e.g., Plasma, Urine):
 - For protein-containing matrices, a protein precipitation step is necessary. Add 3 volumes of cold acetonitrile to 1 volume of the sample, vortex thoroughly, and centrifuge to pellet the precipitated proteins.

- For cleaner samples or following protein precipitation, solid-phase extraction (SPE) can be employed to concentrate the analytes and remove interfering matrix components[6].
- Evaporate the solvent from the cleaned extract under a gentle stream of nitrogen and reconstitute in a solvent compatible with the chromatographic method[6].

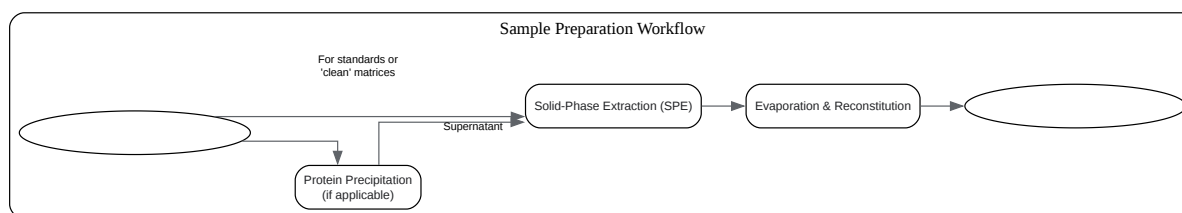

[Click to download full resolution via product page](#)

Figure 1: General sample preparation workflow.

GC-MS Protocol (for Volatile Isomers)

GC-MS with Electron Ionization (EI) is particularly well-suited for the analysis of thermally stable and volatile compounds like the nitrophenetole isomers[7].

- Chromatographic Separation:
 - GC System: Agilent 7890A or equivalent.
 - Column: DB-5MS (30 m x 0.25 mm i.d., 0.25 μ m film thickness) or similar non-polar column[8].
 - Carrier Gas: Helium at a constant flow rate of 1 mL/min.
 - Inlet: Split/splitless injector at 250°C.

- Oven Program: Initial temperature of 100°C, hold for 1 minute, then ramp at 15°C/min to 280°C and hold for 5 minutes[9].
- Mass Spectrometry Detection:
 - MS System: Agilent 5975C or equivalent single quadrupole mass spectrometer.
 - Ionization Mode: Electron Ionization (EI) at 70 eV[10].
 - Source Temperature: 230°C.
 - Quadrupole Temperature: 150°C.
 - Scan Range: m/z 40-400.

LC-MS/MS Protocol

LC-MS/MS with Electrospray Ionization (ESI) is the method of choice for polar and thermally labile compounds like paracetamol[7].

- Chromatographic Separation:
 - LC System: Waters ACQUITY UPLC or equivalent.
 - Column: C18 reversed-phase column (e.g., 50 mm x 2.1 mm, 1.7 µm particle size).
 - Mobile Phase A: 0.1% Formic acid in water.
 - Mobile Phase B: 0.1% Formic acid in acetonitrile.
 - Gradient: Start with 5% B, ramp to 95% B over 5 minutes, hold for 2 minutes, and re-equilibrate at 5% B for 3 minutes.
 - Flow Rate: 0.4 mL/min.
 - Column Temperature: 40°C.
- Mass Spectrometry Detection:

- MS System: Triple quadrupole or Q-TOF mass spectrometer.
- Ionization Mode: Electrospray Ionization (ESI), positive ion mode.
- Capillary Voltage: 3.5 kV.
- Source Temperature: 150°C.
- Desolvation Temperature: 350°C.
- Collision Gas: Argon.
- Data Acquisition: Full scan for precursor ions and product ion scans for fragmentation analysis. Collision energy should be optimized for each compound (typically in the 10-40 eV range).

Comparative Fragmentation Analysis

The structural differences between paracetamol and the nitrophenetole isomers lead to distinct and diagnostic fragmentation patterns.

Paracetamol (Acetaminophen)

Paracetamol's structure, with its amide and hydroxyl groups, dictates its fragmentation.

- Electron Ionization (EI): Under EI conditions, the molecular ion (m/z 151) is observed. The base peak is typically at m/z 109, resulting from the loss of a neutral ketene molecule ($\text{CH}_2=\text{C}=\text{O}$, 42 Da) via a rearrangement process^[8]. Another significant fragment is observed at m/z 43, corresponding to the acetyl cation $[\text{CH}_3\text{CO}]^+$.
- Electrospray Ionization (ESI-MS/MS): In positive ion mode, paracetamol is readily protonated to form the $[\text{M}+\text{H}]^+$ ion at m/z 152. Collision-Induced Dissociation (CID) of this precursor ion predominantly results in a product ion at m/z 110^[11]. This corresponds to the loss of a neutral ketene molecule (42 Da) from the protonated precursor, forming a protonated *p*-aminophenol ion.

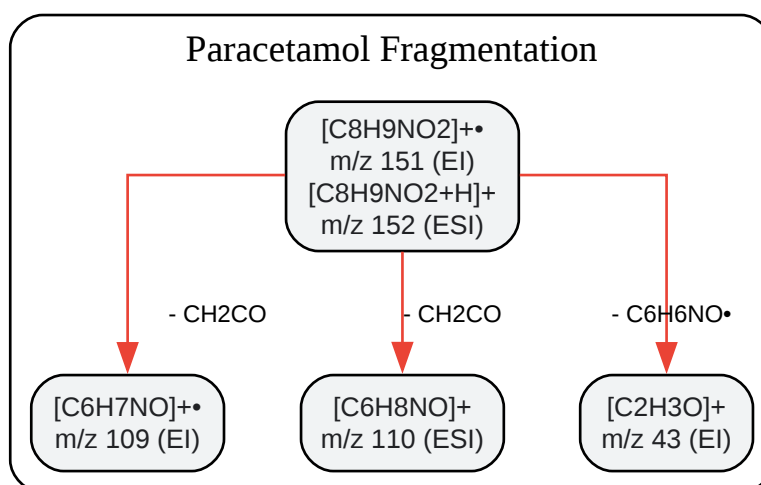

[Click to download full resolution via product page](#)

Figure 2: Key fragmentation pathways for Paracetamol.

Nitrophenetole Isomers (ortho, meta, and para)

The fragmentation of nitrophenetole isomers is heavily influenced by the position of the nitro group, a phenomenon known as the "ortho effect" in mass spectrometry[12].

- Electron Ionization (EI): All three isomers show a molecular ion at m/z 167. The primary fragmentation pathway for all isomers involves the cleavage of the ethyl group.
 - Loss of ethylene (C₂H₄, 28 Da): This is a major fragmentation pathway for all three isomers, leading to a prominent ion at m/z 139, corresponding to the respective nitrophenol radical cation. This occurs via a McLafferty-type rearrangement where a hydrogen from the ethyl group is transferred to the ether oxygen.
 - Loss of an ethyl radical (•C₂H₅, 29 Da): This results in an ion at m/z 138.
 - Further Fragmentation: The nitrophenol ion (m/z 139) undergoes further fragmentation characteristic of nitroaromatic compounds, including the loss of NO (30 Da) to give an ion at m/z 109, and the loss of NO₂ (46 Da) to give an ion at m/z 93. The subsequent loss of CO (28 Da) from m/z 93 yields an ion at m/z 65[13].
- Distinguishing Features (The Ortho Effect):

- 2-Nitrophenetole (ortho): The proximity of the ethoxy and nitro groups facilitates unique interactions upon ionization. A characteristic fragmentation pathway for ortho-substituted nitroaromatics is the loss of a hydroxyl radical ($\bullet\text{OH}$) from the molecular ion, although this is more prominent in related compounds[12][14]. A more distinguishing feature is often the relative intensities of the shared fragments. The ortho isomer can exhibit a more pronounced loss of $\text{C}_2\text{H}_4\text{O}$ (44 Da) leading to a $\text{C}_6\text{H}_5\text{NO}^+$ ion at m/z 123.
- 3-Nitrophenetole (meta) and 4-Nitrophenetole (para): These isomers exhibit very similar fragmentation patterns to each other, dominated by the loss of ethylene (m/z 139) and subsequent fragmentation of the resulting nitrophenol ion. Differentiation between meta and para isomers by EI-MS alone is challenging and often relies on subtle differences in the relative abundances of fragment ions or requires chromatographic separation.

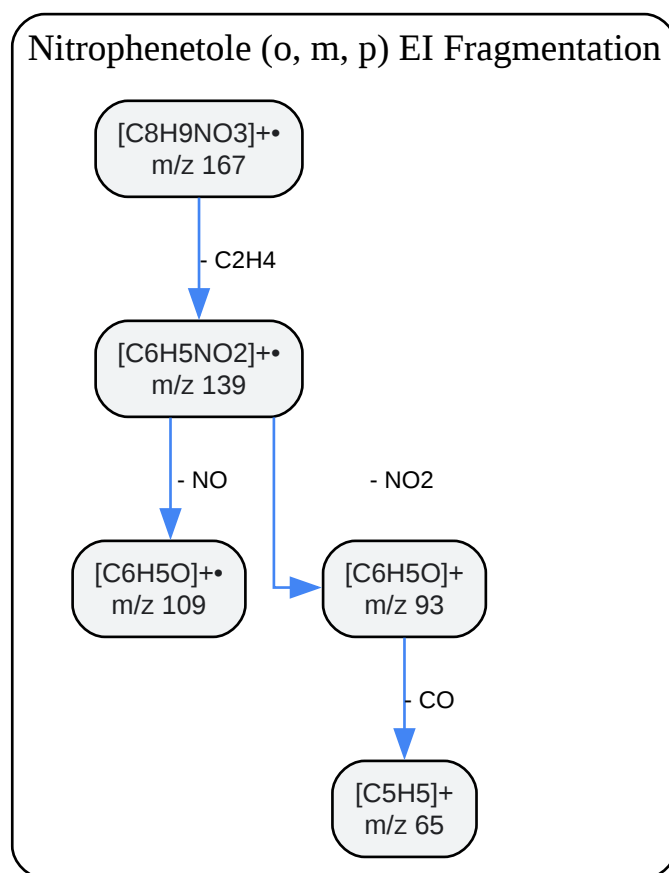

[Click to download full resolution via product page](#)

Figure 3: Common EI fragmentation pathways for Nitrophenetole isomers.

- Electrospray Ionization (ESI-MS/MS): In negative ion mode, the nitrophenetoles readily deprotonate to form the $[M-H]^-$ ion at m/z 166. CID of this precursor typically results in the loss of the ethyl group as ethylene, yielding the nitrophenolate anion at m/z 138. Further fragmentation can involve the loss of NO and NO₂. The ortho isomer may exhibit unique fragmentation pathways due to intramolecular interactions, which can be exploited for differentiation.

Quantitative Data Summary

The following table summarizes the key fragment ions and their typical relative abundances under Electron Ionization (70 eV). Note that relative abundances can vary between instruments.

m/z	Proposed Fragment	Paracetamol	2-Nitrophenetole	3-Nitrophenetole	4-Nitrophenetole
167	$[M]^+$	-	~40%	~60%	~95%
151	$[M]^+$	~30%	-	-	-
139	$[M - C_2H_4]^+$	-	~100%	~100%	~100%
109	$[M - CH_2CO]^+$ (Paracetamol) or $[M - C_2H_4 - NO]^+$ (Nitrophenetoles)	100%	~25%	~30%	~35%
93	$[M - C_2H_4 - NO_2]^+$	-	~15%	~20%	~20%
65	$[C_5H_5]^+$	-	~30%	~40%	~55%
43	$[CH_3CO]^+$	~45%	-	-	-

Conclusion

The differentiation of C₈H₉NO₃ isomers by mass spectrometry is a clear demonstration of the technique's power in structural elucidation.

- Paracetamol is readily distinguished by its characteristic loss of ketene (42 Da) under both EI and ESI conditions, leading to base peaks at m/z 109 and 110, respectively. The presence of an acetyl fragment at m/z 43 in EI is also highly diagnostic.
- Nitrophenetole isomers are characterized by the initial loss of ethylene (28 Da) to form a nitrophenol ion at m/z 139. While the meta and para isomers show very similar fragmentation patterns, the ortho isomer can often be distinguished by subtle differences in fragment ion intensities or the presence of unique, albeit sometimes low abundance, fragments arising from the "ortho effect."

For unequivocal identification, especially between the meta and para isomers of nitrophenetole, the coupling of mass spectrometry with a chromatographic separation technique (GC or LC) is essential. By understanding the fundamental fragmentation mechanisms outlined in this guide, researchers can more confidently interpret their mass spectral data and achieve reliable identification of these and other challenging isomeric compounds.

References

- Furer, V. L., et al. (2018). Investigation of the ionisation and fragmentation behaviour of different nitroaromatic compounds occurring as polar metabolites of explosives using electrospray ionisation tandem mass spectrometry. *Rapid Communications in Mass Spectrometry*, 32(13), 1075-1084.
- Benoit, F. M., & Holmes, J. L. (1969). Mass spectra and fragmentation mechanisms of some nitrophenylhydrazines and nitrophenylhydrazones. *Canadian Journal of Chemistry*, 47(19), 3611-3624.
- Eiceman, G. A., et al. (1995). Sequential ortho effects: characterization of novel [M - 35]⁺ fragment ions in the mass spectra of 2-alkyl-4, 6-dinitrophenols. *Journal of the American Society for Mass Spectrometry*, 6(1), 69-75.
- Bowie, J. H., et al. (1967). Studies in mass spectrometry. Part VIII. peri- and ortho-Effects in the mass spectra of some aromatic nitro-compounds. *Journal of the Chemical Society B: Physical Organic*, 76-82.
- Harvard Center for Mass Spectrometry. (n.d.). Sample Preparation. Retrieved from [\[Link\]](#)

- Hoggard, J. C., & Covey, T. R. (2011). Performance Evaluation of three Liquid Chromatography Mass Spectrometry Methods for Broad Spectrum Drug Screening. *Journal of Analytical Toxicology*, 35(5), 277-287.
- Organomation. (n.d.). Mass Spectrometry Sample Preparation Guide. Retrieved from [\[Link\]](#)
- ResearchGate. (n.d.). shows the ESI mass spectra in the positive ion mode, ESI(+)-MS, of the... [\[Image\]](#). Retrieved from [\[Link\]](#)
- Michigan State University Department of Chemistry. (n.d.). Mass Spectrometry: Fragmentation. Retrieved from [\[Link\]](#)
- University of Illinois School of Chemical Sciences. (n.d.). Sample Preparation. Retrieved from [\[Link\]](#)
- Li, Y., et al. (2024). Recent Advances in Sample Preparation and Chromatographic/Mass Spectrometric Techniques for Detecting Polycyclic Aromatic Hydrocarbons in Edible Oils: 2010 to Present. *Foods*, 13(11), 1684.
- Mass Spectrometry Research Facility, University of Oxford. (n.d.). Sample Preparation Protocol for Open Access MS. Retrieved from [\[Link\]](#)
- Horká, K., et al. (2021). Photochemistry of Nitrophenol Molecules and Clusters: Intra- vs. Inter-Molecular Hydrogen Bond Dynamics. *The Journal of Physical Chemistry A*, 125(32), 7044-7055.
- Arome Science. (2025). GC-MS vs LC-MS: How to Choose for Metabolomics Research. Retrieved from [\[Link\]](#)
- ResearchGate. (n.d.). Fragmentation pattern of paracetamol. [\[Image\]](#). Retrieved from [\[Link\]](#)
- Schug, K. A. (2018). The LCGC Blog: Forensic Drug Analysis: GC–MS versus LC–MS.
- Demarque, D. P., et al. (2016). Fragmentation reactions using electrospray ionization mass spectrometry: An important tool for the structural elucidation and characterization of synthetic and natural products.
- Filip, J., & Oomens, J. (2020). Mass Spectrometry-Based Identification of Ortho-, Meta- and Paraisomers Using Infrared Ion Spectroscopy. ChemRxiv. Preprint.

- University of Colorado Boulder Department of Chemistry. (n.d.). Fragmentation Mechanisms. Retrieved from [\[Link\]](#)
- Taupik, M., et al. (2021). The Type Fragmentation Patterns Confirmed Acetaminophen By Using Liquid Chromatography-Mass Spectroscopy (LCMS) From Herbal Medicine. Elkawnie: Journal of Islamic Science and Technology, 7(2), 340-352.
- Al-Hetlani, E., et al. (2025).
- Shimadzu Corporation. (2019).
- University of Arizona. (n.d.). Fragment Ions - Intro to Mass Spectrometry. Retrieved from [\[Link\]](#)
- Lin, H. R., et al. (2018). Comparison of the Characteristic Mass Fragmentations of Phenethylamines and Tryptamines by Electron Ionization Gas Chromatography Mass Spectrometry, Electrospray and Matrix-Assisted Laser Desorption Ionization Mass Spectrometry. Molecules, 23(7), 1565.
- Michigan State University Department of Chemistry. (n.d.). Mass Spectrometry. Retrieved from [\[Link\]](#)
- Sparkman, O. D. (2020). Anatomy of an Ion's Fragmentation After Electron Ionization, Part I.
- LibreTexts Chemistry. (2022). 3.1: Electron Ionization. Retrieved from [\[Link\]](#)
- Quora. (2019). On the basis of NMR spectroscopy, how will you distinguish o-nitrophenol and p-nitrophenol? Retrieved from [\[Link\]](#)
- Zenodo. (n.d.). Paracetamol Analysis using HPLC laboratory report.docx. Retrieved from [\[Link\]](#)
- Trivedi, M. K., et al. (2016). Evaluation of Isotopic Abundance Ratio in Biofield Energy Treated Nitrophenol Derivatives Using Gas Chromatography-Mass Spectrometry. American Journal of Chemical Engineering, 4(3), 68-77.
- Spectroscopy Online. (2020). Anatomy of an Ion's Fragmentation After Electron Ionization, Part II. Retrieved from [\[Link\]](#)
- Bonacci, S., et al. (2017). Gas-Phase Fragmentation Analysis of Nitro-Fatty Acids. Journal of the American Society for Mass Spectrometry, 28(8), 1629-1641.

- LibreTexts Chemistry. (2023). Mass Spectrometry - Fragmentation Patterns. Retrieved from [\[Link\]](#)

Need Custom Synthesis?

BenchChem offers custom synthesis for rare earth carbides and specific isotopic labeling.

Email: info@benchchem.com or [Request Quote Online](#).

Sources

- [1. uab.edu](http://1.uab.edu) [uab.edu]
- [2. orgchemboulder.com](http://2.orgchemboulder.com) [orgchemboulder.com]
- [3. Sample Preparation | Harvard Center for Mass Spectrometry](http://3.Sample%20Preparation%20|%20Harvard%20Center%20for%20Mass%20Spectrometry) [massspec.fas.harvard.edu]
- [4. organomation.com](http://4.organomation.com) [organomation.com]
- [5. Sample Preparation Protocol for Open Access MS | Mass Spectrometry Research Facility](http://5.Sample%20Preparation%20Protocol%20for%20Open%20Access%20MS%20|%20Mass%20Spectrometry%20Research%20Facility) [massspec.chem.ox.ac.uk]
- [6. Recent Advances in Sample Preparation and Chromatographic/Mass Spectrometric Techniques for Detecting Polycyclic Aromatic Hydrocarbons in Edible Oils: 2010 to Present - PMC](http://6.Recent%20Advances%20in%20Sample%20Preparation%20and%20Chromatographic/Mass%20Spectrometric%20Techniques%20for%20Detecting%20Polycyclic%20Aromatic%20Hydrocarbons%20in%20Edible%20Oils%20:2010%20to%20Present%20-PMC) [pmc.ncbi.nlm.nih.gov]
- [7. Performance Evaluation of three Liquid Chromatography Mass Spectrometry Methods for Broad Spectrum Drug Screening - PMC](http://7.Performance%20Evaluation%20of%20three%20Liquid%20Chromatography%20Mass%20Spectrometry%20Methods%20for%20Broad%20Spectrum%20Drug%20Screening%20-%20PMC) [pmc.ncbi.nlm.nih.gov]
- [8. jurnal.ar-raniry.ac.id](http://8.jurnal.ar-raniry.ac.id) [jurnal.ar-raniry.ac.id]
- [9. chem.libretexts.org](http://9.chem.libretexts.org) [chem.libretexts.org]
- [10. researchgate.net](http://10.researchgate.net) [researchgate.net]
- [11. Studies in mass spectrometry. Part VIII. peri- and ortho-Effects in the mass spectra of some aromatic nitro-compounds - Journal of the Chemical Society B: Physical Organic \(RSC Publishing\)](http://11.Studies%20in%20mass%20spectrometry.%20Part%20VIII.%20peri-%20and%20ortho-Effects%20in%20the%20mass%20spectra%20of%20some%20aromatic%20nitro-compounds%20-%20Journal%20of%20the%20Chemical%20Society%20B:%20Physical%20Organic%20(RSC%20Publishing)) [pubs.rsc.org]
- [12. spectroscopyonline.com](http://12.spectroscopyonline.com) [spectroscopyonline.com]
- [13. cdnsiencepub.com](http://13.cdnsiencepub.com) [cdnsiencepub.com]
- [14. researchgate.net](http://14.researchgate.net) [researchgate.net]
- To cite this document: BenchChem. [A Comparative Guide to the Mass Spectrometric Fragmentation of C₈H₉NO₃ Isomers]. BenchChem, [2026]. [Online PDF]. Available at:

[<https://www.benchchem.com/product/b6201953/docs#a-comparative-guide-to-the-mass-spectrometric-fragmentation-of-c8h9no3-isomers>]

Disclaimer & Data Validity:

The information provided in this document is for Research Use Only (RUO) and is strictly not intended for diagnostic or therapeutic procedures. While BenchChem strives to provide accurate protocols, we make no warranties, express or implied, regarding the fitness of this product for every specific experimental setup.

Technical Support: The protocols provided are for reference purposes. Unsure if this reagent suits your experiment?

Need Industrial/Bulk Grade? [Request Custom Synthesis Quote](#)

BenchChem

Our mission is to be the trusted global source of essential and advanced chemicals, empowering scientists and researchers to drive progress in science and industry.

Contact

Address: 3281 E Guasti Rd
Ontario, CA 91761, United States
Phone: (601) 213-4426
Email: info@benchchem.com

[Contact our Ph.D. Support Team for a compatibility check](#)