

# Technical Support Center: Optimizing Sulfonation of Benzothiazole

**Author:** BenchChem Technical Support Team. **Date:** May 2026

## Compound of Interest

Compound Name: *1,3-Benzothiazole-7-sulfonic acid*

CAS No.: *159555-57-4*

Cat. No.: *B062399*

[Get Quote](#)

Topic: Reaction Conditions, Selectivity Control, and Troubleshooting Audience: Process Chemists, Medicinal Chemists, Chemical Engineers

## Core Reaction Overview & Strategic Analysis

The Challenge: Sulfonation of benzothiazole is a classic Electrophilic Aromatic Substitution (EAS). However, the fused thiazole ring exerts a strong electron-withdrawing effect, deactivating the benzene ring and complicating regioselectivity.

- Target Product: Typically Benzothiazole-6-sulfonic acid (major isomer).[1]
- Common Byproducts: Benzothiazole-4-sulfonic acid (minor isomer), Benzothiazole-2-sulfonic acid (via different mechanism), and disulfonated species.
- Mechanism: The reaction proceeds via the attack of the electrophile ( or ) on the most electron-rich position of the deactivated benzene ring.

## Critical Distinction: The "2-Position" Trap

Many researchers confuse direct sulfonation (EAS) with the synthesis of Benzothiazole-2-sulfonic acid.

- C6-Sulfonation: Achieved via Oleum/  
  
(Electrophilic attack).
- C2-Sulfonation: Achieved via oxidation of 2-mercaptobenzothiazole (Nucleophilic/Radical pathway).
- This guide focuses on the Electrophilic Sulfonation of the benzothiazole core (C6/C4).

## Standard Operating Procedures (SOPs)

### Protocol A: Direct Sulfonation with Oleum (Fuming Sulfuric Acid)

Best for: High-throughput synthesis of the 6-isomer.

Parameter	Recommended Condition	Technical Rationale
Reagent	20-30% Oleum ( in )	Free is the active electrophile required to overcome ring deactivation.
Stoichiometry	Excess (Solvent quantity)	Acts as both solvent and reagent; maintains high dielectric constant to stabilize the sigma-complex.
Temperature	90°C – 120°C	Activation energy barrier is high due to the deactivated ring. <90°C leads to low conversion; >130°C promotes disulfonation.
Time	2 – 4 Hours	Monitor via HPLC. Extended times favor thermodynamic equilibration (potentially increasing 4-isomer or disulfonation).
Quenching	Pour onto Crushed Ice	Exothermic hydrolysis of excess must be controlled to prevent desulfonation (reversible reaction).

## Protocol B: "Bake" Method (Solvent-Free)

Best for: Reducing acid waste and improving regioselectivity.

- Mix: 1.0 eq Benzothiazole + 1.05 eq (98%).
- Salt Formation: A solid salt forms immediately.

- Bake: Heat the solid salt in a vacuum oven at 180°C - 200°C for 4-6 hours.
- Mechanism: This proceeds via the "rearrangement" of the N-sulfonate or direct solid-state sulfonation, often yielding higher para-selectivity (C6) relative to the nitrogen.

## Troubleshooting Guide (FAQ Format)

### Issue 1: "I am seeing a mixture of isomers (C4 and C6). How do I improve selectivity?"

Diagnosis: The 4-position is ortho to the bridgehead nitrogen, while the 6-position is para. Both are deactivated, but steric hindrance usually disfavors C4. High temperatures can overcome this steric barrier. Corrective Action:

- Lower the Temperature: Reduce reaction temperature to 80-90°C and extend reaction time. This favors the kinetic product (C6) over the thermodynamic mixture.
- Switch Reagents: Use Chlorosulfonic acid ( ) at lower temperatures (0-20°C). The chlorosulfonyl group is bulkier, further disfavoring the C4 position sterically.

### Issue 2: "My yield is low (<40%) and I can't precipitate the product."

Diagnosis: Benzothiazole sulfonic acids are "zwitterionic" and highly water-soluble (hydrophilic). They often refuse to precipitate from the strongly acidic quench mixture.

Corrective Action:

- The "Salting Out" Trick: Do not just neutralize to pH 7. The sulfonic acid is most soluble as a salt. Instead, adjust pH to the isoelectric point (approx pH 1-2) where the zwitterion is least soluble.
- Barium Isolation: Add  
  
or  
  
to precipitate the insoluble Barium sulfonate, filter, then regenerate the acid with

stoichiometric

.

- Alternative Workup: Dilute the oleum mixture with ice, then add NaCl to saturation. The Sodium salt (Sodium benzothiazole-6-sulfonate) often precipitates ("Common Ion Effect").

### Issue 3: "The reaction mixture turned into a black tar."

Diagnosis: Oxidative decomposition. The thiazole ring is sensitive to ring-opening under harsh oxidative conditions. Corrective Action:

- Check Oleum Strength: If using >60% Oleum, the oxidizing power is too high. Dilute with 98%

to reach ~20% free

.

- Inert Atmosphere: Run the reaction under Nitrogen. While sulfonation isn't oxidation, hot acts as an oxidant at >150°C.

### Mechanistic Visualization

The following diagram illustrates the electrophilic aromatic substitution pathway, highlighting the competition between the C6 and C4 positions.

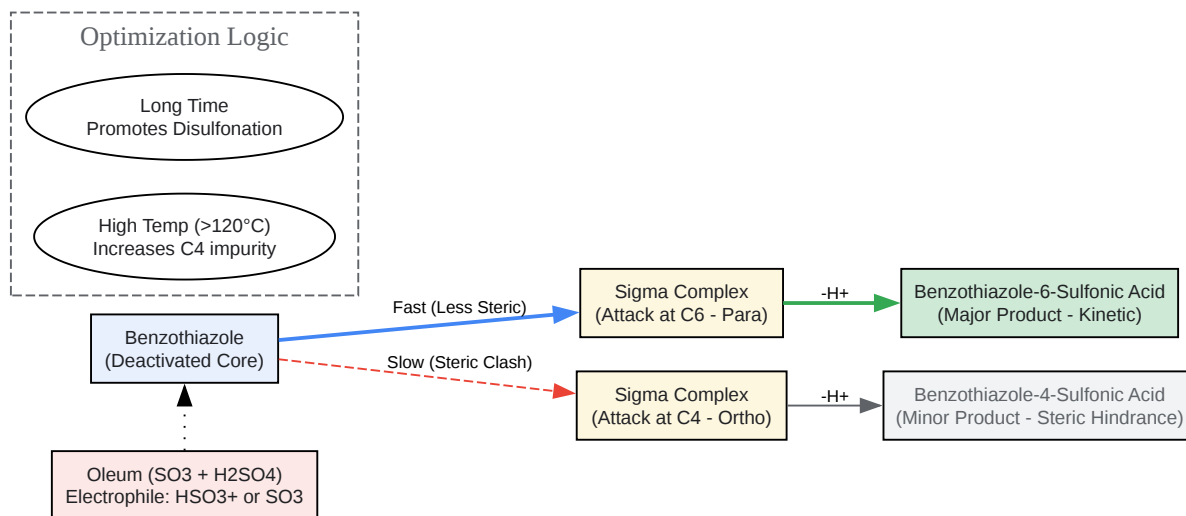

[Click to download full resolution via product page](#)

Caption: Mechanistic pathway of benzothiazole sulfonation. The C6 position is favored due to lower steric hindrance compared to C4, despite both being deactivated by the thiazole ring.

## Troubleshooting Decision Tree

Use this workflow to diagnose yield or purity issues immediately.

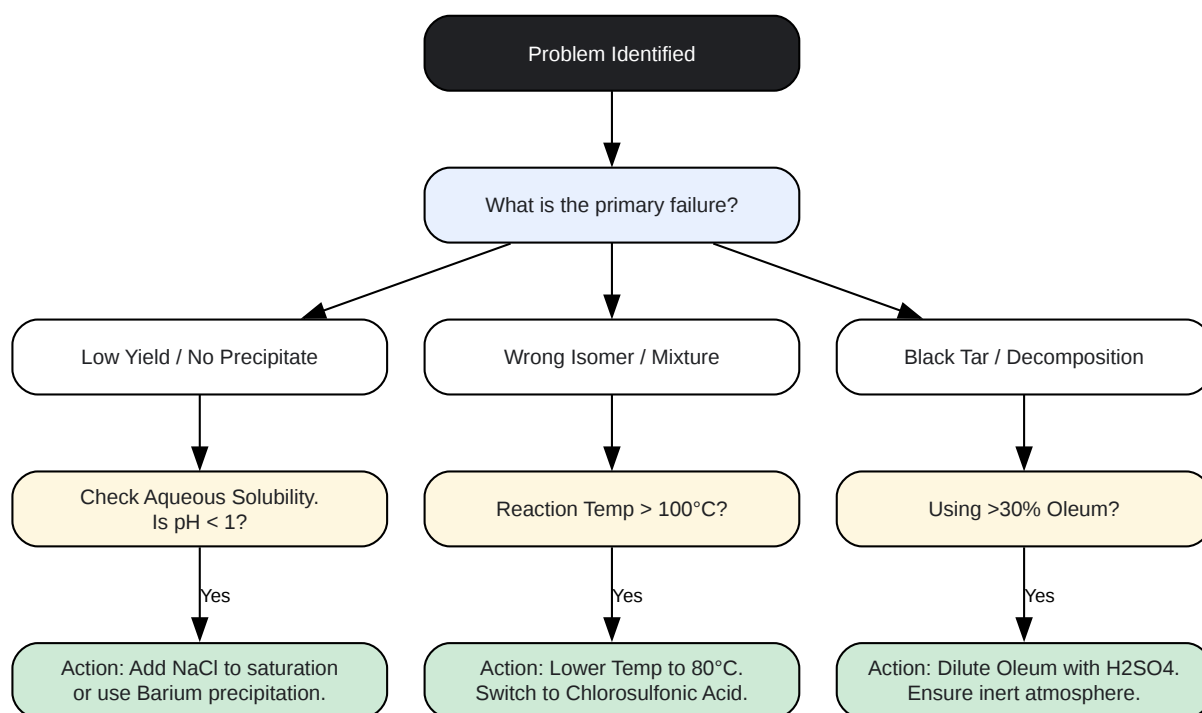

[Click to download full resolution via product page](#)

Caption: Diagnostic decision tree for troubleshooting common sulfonation failures.

## References

- Direct Sulfonation & Isomer Distribution: Journal of the Chemical Society, "Electrophilic substitution in benzothiazole. Part II. The bromination of the aminobenzothiazoles" (Context on electrophilic direction). [Link](#) (Note: Classical grounding for C6/C4 selectivity).
- Industrial Sulfonation Conditions: BenchChem Technical Review, "Benzothiazole-2-sulfonic acid vs 6-sulfonic acid synthesis pathways." [Link](#)
- Synthesis of 6-Sulfonic Acid Derivatives: ResearchGate, "Synthesis of benzothiazole-6-sulfonic acid derivatives." [2] [Link](#)
- Purification of Sulfonic Acids: US Patent 3496224A, "Purification of sulfonic acids." [Link](#)

- General Mechanism of Aromatic Sulfonation: Master Organic Chemistry, "Sulfonation of Benzene and Derivatives." [Link](#)

### Need Custom Synthesis?

BenchChem offers custom synthesis for rare earth carbides and specific isotopic labeling.

Email: [info@benchchem.com](mailto:info@benchchem.com) or [Request Quote Online](#).

## Sources

- 1. CN103073522A - Synthesis method of 2,2' -biazoyl-di (3-ethyl-benzothiazole-6-sulfonic acid) diammonium salt - Google Patents [[patents.google.com](https://patents.google.com)]
- 2. [researchgate.net](https://www.researchgate.net) [[researchgate.net](https://www.researchgate.net)]
- To cite this document: BenchChem. [Technical Support Center: Optimizing Sulfonation of Benzothiazole]. BenchChem, [2026]. [Online PDF]. Available at: [<https://www.benchchem.com/product/b062399/docs#technical-support-center-optimizing-sulfonation-of-benzothiazole>]

---

### Disclaimer & Data Validity:

The information provided in this document is for Research Use Only (RUO) and is strictly not intended for diagnostic or therapeutic procedures. While BenchChem strives to provide accurate protocols, we make no warranties, express or implied, regarding the fitness of this product for every specific experimental setup.

**Technical Support:** The protocols provided are for reference purposes. Unsure if this reagent suits your experiment?

**Need Industrial/Bulk Grade?** [Request Custom Synthesis Quote](#)

# BenchChem

Our mission is to be the trusted global source of essential and advanced chemicals, empowering scientists and researchers to drive progress in science and industry.

## Contact

Address: 3281 E Guasti Rd

Ontario, CA 91761, United States

Phone: (601) 213-4426

Email: [info@benchchem.com](mailto:info@benchchem.com)

[Contact our Ph.D. Support Team for a compatibility check](#)