

# Technical Guide: 4-Substituted Proline Analogs in Peptide Chemistry

**Author:** BenchChem Technical Support Team. **Date:** May 2026

## Compound of Interest

**Compound Name:** *N-BOC-TRANS-4-CYANO-L-PROLINE METHYL ESTER*

**CAS No.:** 194163-91-2

**Cat. No.:** B062349

[Get Quote](#)

## Executive Summary

Proline is the only proteinogenic amino acid where the side chain cyclizes onto the backbone nitrogen, restricting the

dihedral angle and eliminating the amide hydrogen donor. This unique architecture makes proline a critical determinant of secondary structure (turns, helices) and proteolytic stability.

4-Substituted Proline Analogs (e.g., 4-hydroxyproline, 4-fluoroproline) act as "conformational switches."<sup>[1]</sup> By introducing electron-withdrawing groups (EWG) or steric bulk at the C4 position, chemists can stereoselectively tune the pyrrolidine ring pucker (

-endo vs.

-exo) and the peptide bond equilibrium (cis vs. trans).

This guide provides a mechanistic framework for selecting the correct analog to lock bioactive conformations, enhance thermal stability, or modulate folding kinetics.

# Structural Mechanistics: The Stereoelectronic Engine

The utility of 4-substituted prolines stems from two competing forces: the Gauche Effect (stereoelectronic) and Steric Repulsion. These forces dictate the ring pucker, which in turn controls the cis/trans ratio of the peptide bond (

angle).

## The Gauche Effect

In 4-substituted prolines with electron-withdrawing groups (OH, F,

), the ring prefers a conformation where the C–X bond and the adjacent C–N bond are gauche (synclinal) rather than anti. This maximizes the hyperconjugative overlap between the electron-rich

orbital and the electron-deficient

orbital.

- (4R)-EWG (e.g., Hyp, Flp): Favors  
-exo pucker.<sup>[2][3][4][5]</sup>
  - Result: Stabilizes the trans peptide bond ( ).
  - Mechanism: The exo pucker positions the carbonyl and the carbonyl in proximity, facilitating a stabilizing interaction.
- (4S)-EWG (e.g., hyp, flp): Favors  
-endo pucker.<sup>[3][4][5][6]</sup>

- Result: Destabilizes the trans state, increasing the cis population.
- Mechanism: The endo pucker disrupts the geometry and places the substituent in a pseudo-axial position if forced into exo.

## Steric Effects (Alkyl Substituents)

For non-electronegative groups (e.g., Methyl), steric bulk dominates. The substituent prefers the pseudo-equatorial position to minimize 1,3-diaxial interactions.

- (4R)-Methyl: Favors  
-endo (Substituent is pseudo-equatorial).[3]
- (4S)-Methyl: Favors  
-exo (Substituent is pseudo-equatorial).[3]

## Conformational Logic Diagram

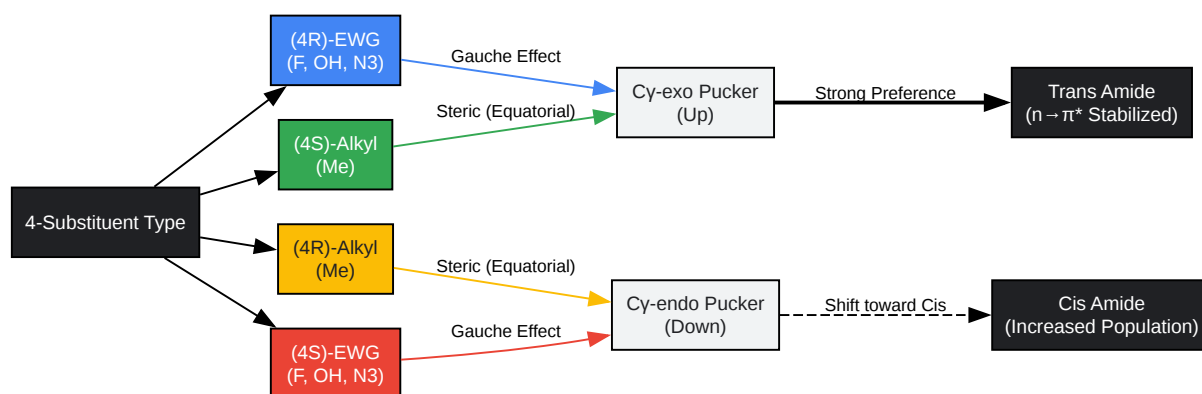

[Click to download full resolution via product page](#)

Figure 1: Decision tree for selecting proline analogs based on desired conformational outcome. (4R)-EWG and (4S)-Alkyl stabilize the exo/trans state, while (4S)-EWG and (4R)-Alkyl shift equilibrium toward endo/cis.

## Functional Impact Summary

The following table summarizes the physicochemical properties of key analogs relative to native Proline.

Analog	Configura tion	Substitue nt	Dominant Effect	Preferred Pucker		Applicati on
Proline (Pro)	-	H	-	Mixed ( )	~4.6	Standard
(4R)- Hydroxypro line (Hyp)	2S, 4R	OH	Stereoelect ronic	-Exo	> 6.0	Collagen stability
(4S)- Hydroxypro line (hyp)	2S, 4S	OH	Stereoelect ronic	-Endo	~ 2.0	-turn induction
(4R)- Fluoroprol ine (Flp)	2S, 4R	F	Stereoelect ronic (Strong)	-Exo	> 6.7	Hyperstabil ity, Folding
(4S)- Fluoroprol ine (flp)	2S, 4S	F	Stereoelect ronic (Strong)	-Endo	~ 2.5	Destabiliza tion, Cis- locking
(4S)- Methylproli ne	2S, 4S	CH3	Steric	-Exo	High	Hydrophobi c stability

Key Insight: Fluorine exerts a stronger gauche effect than hydroxyl due to higher electronegativity, making Flp the gold standard for locking trans conformations [1].

## Synthetic Methodologies

Researchers typically employ two strategies: direct incorporation of pre-synthesized building blocks or "Proline Editing" directly on the solid phase.

## Method A: Direct Incorporation (SPPS)

Commercial Fmoc-protected analogs (e.g., Fmoc-Hyp(tBu)-OH, Fmoc-Flp-OH) are compatible with standard Fmoc/tBu SPPS protocols.

Protocol:

- Coupling: Use DIC/Oxyma or HATU/DIEA. 4-substituted prolines are sterically hindered; extend coupling times (2x 45 min).
- Deprotection: Standard 20% Piperidine in DMF.
- Cleavage: TFA/TIS/Water (95:2.5:2.5). Note: Fluoroproline is stable to TFA.

## Method B: Proline Editing (On-Resin Modification)

This powerful technique allows the generation of diverse libraries from a single precursor (Fmoc-Hyp-OH) anchored to the resin [2].

Workflow:

- Scaffold Synthesis: Incorporate Fmoc-Hyp(Trt)-OH or Fmoc-Hyp-OH (unprotected side chain) into the peptide.
- Site-Specific Functionalization: Perform reactions on the free secondary hydroxyl group while the peptide remains on the resin.

Example Protocol: Synthesis of 4-Azidoproline (Azp) via Mitsunobu

- Purpose: Inversion of stereochemistry (4R-OH

4S-

) to access "Click" chemistry handles or modulate pucker.

- Reagents: Triphenylphosphine (

), Diisopropyl azodicarboxylate (DIAD), Diphenylphosphoryl azide (DPPA) or

source.

## Step-by-Step:

- Swell Resin: DCM (3x).
- Prepare Mixture: Dissolve (5 eq) and DIAD (5 eq) in dry THF/DCM (1:1). Add DPPA (5 eq).
- Reaction: Add mixture to resin-bound peptide (with free 4R-OH). Agitate for 4–16 hours under Argon.
- Wash: THF (5x), DCM (5x).
- Result: The reaction inverts the center, yielding (4S)-Azidoproline.

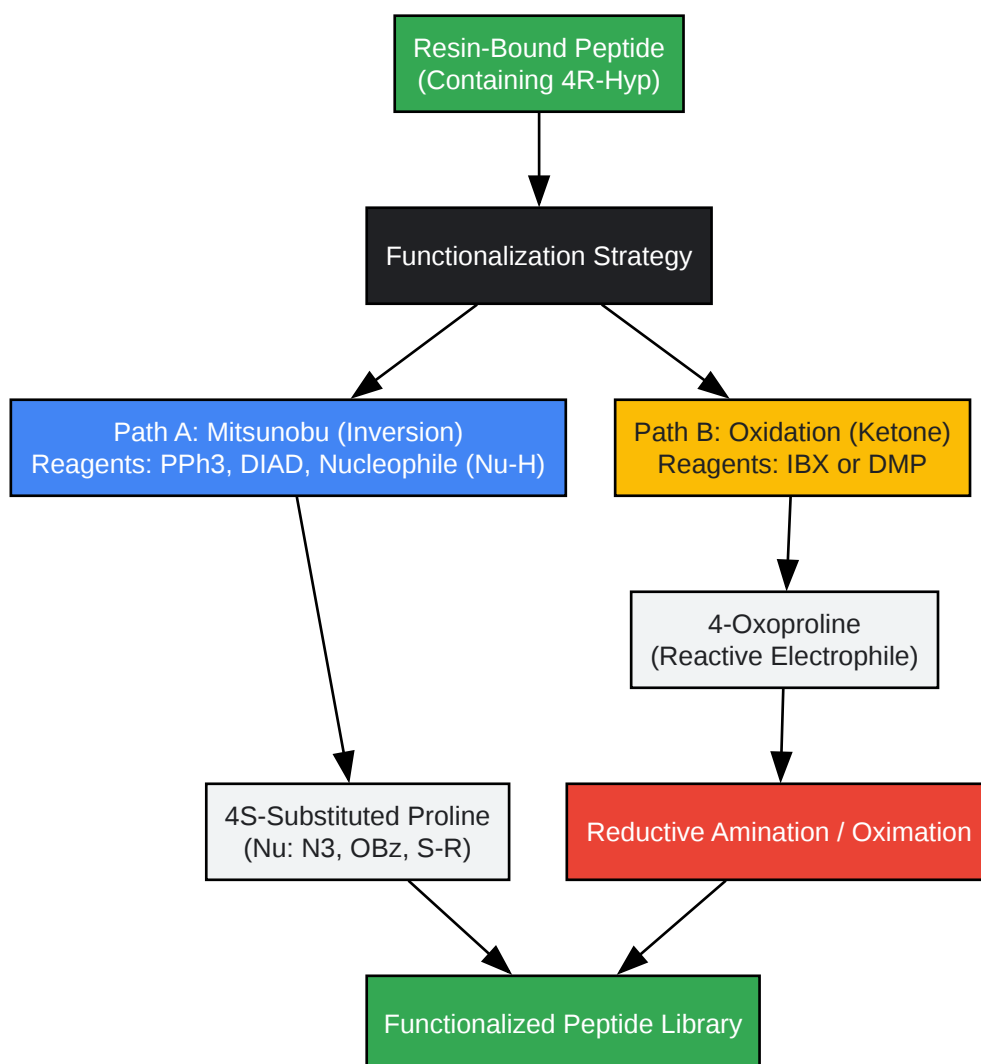

[Click to download full resolution via product page](#)

Figure 2: Proline Editing workflow. Path A utilizes the Mitsunobu reaction to invert stereochemistry and install nucleophiles. Path B creates a ketone handle for further diversification.

## Case Studies & Applications

### Collagen Hyperstability

The collagen triple helix requires Proline in the X position and 4R-Hydroxyproline (Hyp) in the Y position of the

repeat.

- Experiment: Replacing Hyp with (4R)-Fluoroproline (Flp).
- Outcome: The melting temperature ( ) increases significantly (Hyperstability).[3]
- Reasoning: Flp has a higher electronegativity than Hyp, enforcing a stronger -exo pucker and pre-organizing the strand into the required Polyproline II (PPII) helix geometry [3].

## Locking Bioactive Conformations (Peptidomimetics)

In drug design, flexible peptides incur a high entropy penalty upon binding.

- Strategy: If the bioactive conformation requires a cis-amide (common in -turn VI), replace Pro with (4S)-Fluoroproline or (4R)-Methylproline.
- Validation: Verify the conformation using NMR ( coupling constants) or CD spectroscopy. A shift in equilibrium toward cis can increase binding affinity by orders of magnitude.

## References

- Stereoelectronic effects on the transition barrier of polyproline conformational interconversion. Source: National Institutes of Health (NIH) / PMC URL:[[Link](#)]
- Proline Editing: A General and Practical Approach to the Synthesis of Functionally and Structurally Diverse Peptides. Source: Journal of the American Chemical Society (JACS) URL:[[Link](#)]
- Stereoelectronic and steric effects in side chains preorganize a protein main chain. Source: Proceedings of the National Academy of Sciences (PNAS) URL:[[Link](#)]
- Practical syntheses of 4-fluoroprolines. Source: National Institutes of Health (NIH) / PMC URL:[[Link](#)]

- 4-Fluoroprolines: Conformational Analysis and Effects on the Stability and Folding of Peptides and Proteins. Source: Raines Lab / PMC URL:[[Link](#)]

### Need Custom Synthesis?

BenchChem offers custom synthesis for rare earth carbides and specific isotopic labeling.

Email: [info@benchchem.com](mailto:info@benchchem.com) or [Request Quote Online](#).

## Sources

- 1. [raineslab.com](https://raineslab.com) [[raineslab.com](https://raineslab.com)]
- 2. [pubs.acs.org](https://pubs.acs.org) [[pubs.acs.org](https://pubs.acs.org)]
- 3. [pnas.org](https://pnas.org) [[pnas.org](https://pnas.org)]
- 4. [eprints.soton.ac.uk](https://eprints.soton.ac.uk) [[eprints.soton.ac.uk](https://eprints.soton.ac.uk)]
- 5. Practical syntheses of 4-fluoroprolines - PMC [[pmc.ncbi.nlm.nih.gov](https://pmc.ncbi.nlm.nih.gov)]
- 6. [researchgate.net](https://researchgate.net) [[researchgate.net](https://researchgate.net)]
- To cite this document: BenchChem. [Technical Guide: 4-Substituted Proline Analogs in Peptide Chemistry]. BenchChem, [2026]. [Online PDF]. Available at: [<https://www.benchchem.com/product/b062349/docs#technical-guide-4-substituted-proline-analogs-in-peptide-chemistry>]

### Disclaimer & Data Validity:

The information provided in this document is for Research Use Only (RUO) and is strictly not intended for diagnostic or therapeutic procedures. While BenchChem strives to provide accurate protocols, we make no warranties, express or implied, regarding the fitness of this product for every specific experimental setup.

**Technical Support:** The protocols provided are for reference purposes. Unsure if this reagent suits your experiment?

**Need Industrial/Bulk Grade?** [Request Custom Synthesis Quote](#)

# BenchChem

Our mission is to be the trusted global source of essential and advanced chemicals, empowering scientists and researchers to drive progress in science and industry.

## Contact

Address: 3281 E Guasti Rd

Ontario, CA 91761, United States

Phone: (601) 213-4426

Email: [info@benchchem.com](mailto:info@benchchem.com)

[Contact our Ph.D. Support Team for a compatibility check](#)