

# A Comparative Guide to Orthogonal Protection Schemes Involving Boc-Glycine

**Author:** BenchChem Technical Support Team. **Date:** May 2026

## Compound of Interest

Compound Name: *(Tert-butylamino)(oxo)acetic acid*

CAS No.: 169772-25-2

Cat. No.: B062520

[Get Quote](#)

In the intricate field of peptide synthesis and drug development, the strategic selection of protecting groups is a critical determinant of success. The ability to selectively mask and unmask functional groups with high fidelity allows for the precise construction of complex molecular architectures. This guide provides an objective comparison of orthogonal protection schemes centered around tert-butoxycarbonyl (Boc)-glycine, a fundamental building block in peptide chemistry. We will delve into its performance juxtaposed with other common N- $\alpha$ -protecting groups for glycine—namely, 9-fluorenylmethoxycarbonyl (Fmoc) and benzyloxycarbonyl (Cbz)—supported by experimental data and detailed protocols to inform synthetic strategies.

## The Principle of Orthogonality in Peptide Synthesis

At its core, peptide synthesis is a repetitive process of amide bond formation between amino acids. To ensure the correct sequence, the reactive  $\alpha$ -amino group of the incoming amino acid and any reactive side chains must be temporarily masked.<sup>[1]</sup> An ideal protecting group strategy, termed "orthogonal," allows for the selective removal of one type of protecting group under specific conditions without affecting others.<sup>[2][3]</sup> This principle is paramount for multi-step syntheses, enabling the sequential and controlled modification of a molecule.<sup>[4][5]</sup>

The three most common N- $\alpha$ -protecting groups—Boc, Fmoc, and Cbz—form a powerful orthogonal set, as their removal conditions are distinct:

- Boc (tert-Butoxycarbonyl): Cleaved under acidic conditions (e.g., trifluoroacetic acid, TFA).[2]
- Fmoc (9-Fluorenylmethoxycarbonyl): Cleaved under basic conditions (e.g., piperidine).[2]
- Cbz (Carboxybenzyl or Z): Cleaved by catalytic hydrogenolysis.[6]

This differential lability is the foundation of modern solid-phase peptide synthesis (SPPS).[2]

## Comparison of N- $\alpha$ -Protecting Groups for Glycine

The choice between Boc, Fmoc, and Cbz for protecting glycine depends on the overall synthetic strategy, the nature of the target peptide, and compatibility with other protecting groups.

**Boc-Glycine:** A cornerstone of early and still relevant peptide synthesis, the Boc group is highly effective, particularly in the "Boc/Bzl" strategy where benzyl-based groups protect side chains.[7] This strategy is considered semi-orthogonal because both Boc and benzyl groups are removed by acid, albeit of different strengths.[2] The repetitive acid treatment in Boc-SPPS can be advantageous for synthesizing long or hydrophobic peptides prone to aggregation, as it keeps the growing peptide chain protonated, which helps to disrupt secondary structures and improve solubility.[4][8] However, the final cleavage of the peptide from the resin often requires harsh and hazardous acids like hydrofluoric acid (HF).[9]

**Fmoc-Glycine:** The Fmoc group is the foundation of the most widely used SPPS strategy, the "Fmoc/tBu" approach.[10] Here, the N-terminal Fmoc group is removed by a mild base, while acid-labile tert-butyl (tBu)-based groups protect the side chains.[11] This system is fully orthogonal, and the milder conditions for both iterative deprotection and final cleavage make it compatible with a wider range of sensitive modifications and amenable to automation.[2][10] However, Fmoc-protected amino acids are generally more expensive, and aggregation can be an issue for certain sequences.[2]

**Cbz-Glycine:** The Cbz group is stable to both acidic and basic conditions, offering robustness.[6] Its removal via hydrogenolysis provides an additional layer of orthogonality, making it valuable in solution-phase synthesis and for protecting side-chain amino functions (e.g., in

lysine) when both acid- and base-labile groups are present elsewhere in the molecule. It is less commonly used for N- $\alpha$ -protection in modern SPPS due to the incompatibility of catalytic hydrogenation with solid supports and sulfur-containing residues.[2]

## Quantitative Data Summary

The following tables summarize key comparative data for Boc-, Fmoc-, and Cbz-glycine to facilitate an evidence-based selection process.

Table 1: Comparison of Glycine Protection Strategies

Parameter	Boc-Glycine	Fmoc-Glycine	Cbz-Glycine
Protection Reagent	Di-tert-butyl dicarbonate ((Boc) <sub>2</sub> O)	Fmoc-OSu or Fmoc-Cl	Benzyl chloroformate (Cbz-Cl)
Typical Protection Yield	90-95%	>95%	~88%
Deprotection Condition	Acidolysis (e.g., 50% TFA in DCM)	Base (e.g., 20% piperidine in DMF)[12]	Catalytic Hydrogenolysis (H <sub>2</sub> , Pd/C)
Orthogonal To	Base-labile (Fmoc), Hydrogenolysis-labile (Cbz) groups[2]	Acid-labile (Boc, tBu), Hydrogenolysis-labile (Cbz) groups[2]	Acid-labile (Boc, tBu), Base-labile (Fmoc) groups[2]
Primary Application	Boc/Bzl SPPS, especially for long/hydrophobic peptides[4][8]	Fmoc/tBu SPPS (most common)[10]	Solution-phase synthesis, side-chain protection[6]
Potential Side Reactions	Acid-catalyzed side reactions with sensitive residues (e.g., Trp)[2]	Diketopiperazine formation at the dipeptide stage[1]	Incomplete removal in the presence of sulfur[2]

Table 2: Orthogonality with Common Side-Chain and Linker Chemistries

Protecting Group	Boc (Acid-Labile)	Fmoc (Base-Labile)	Cbz (Hydrogenolysis)
Side-Chain Protection			
tBu (tert-Butyl)	Not Orthogonal	Orthogonal	Orthogonal
Bzl (Benzyl)	Semi-Orthogonal[2]	Orthogonal	Not Orthogonal
Alloc (Allyloxycarbonyl)	Orthogonal	Orthogonal	Orthogonal
Trt (Trityl)	Not Orthogonal	Orthogonal	Orthogonal
Resin Linker Cleavage			
Merrifield (HF)	Compatible	Compatible	Compatible
Wang (TFA)	Not Orthogonal	Compatible	Compatible
Rink Amide (TFA)	Not Orthogonal	Compatible	Compatible

## Experimental Protocols

Detailed methodologies are crucial for reproducibility. The following are representative protocols for key experiments involving Boc-glycine.

### Protocol 1: Standard Boc-SPPS Cycle for a Single Glycine Coupling

This protocol outlines the steps for deprotection, neutralization, and coupling on a solid support, such as a Merrifield resin.

Materials:

- Peptide-resin with a free N-terminal amine
- Boc-Glycine
- Coupling reagent (e.g., HBTU)

- N,N-Diisopropylethylamine (DIEA)
- Trifluoroacetic acid (TFA)
- Dichloromethane (DCM)
- N,N-Dimethylformamide (DMF)
- Kaiser test kit

Procedure:

- Resin Swelling: Swell the resin in DCM for 30 minutes.[4]
- Boc Deprotection:
  - Add a solution of 50% TFA in DCM (v/v) to the resin and agitate for 1-2 minutes. Drain.[2]
  - Add a fresh portion of 50% TFA in DCM and agitate for 20-30 minutes.[2]
  - Drain the deprotection solution and wash the resin thoroughly with DCM (3-5 times).[1]
- Neutralization:
  - Add a solution of 10% DIEA in DCM (v/v) to the resin and agitate for 5 minutes.[4]
  - Drain and repeat the neutralization step.
  - Wash the resin thoroughly with DCM (3-5 times) to remove excess base.[1]
- Amino Acid Coupling:
  - In a separate vessel, dissolve Boc-Glycine (3 eq.) and HBTU (2.9 eq.) in DMF.
  - Add DIEA (6 eq.) to the amino acid solution to pre-activate it for a few minutes.
  - Add the activated amino acid solution to the neutralized resin.
  - Agitate the reaction mixture for 1-2 hours at room temperature.[12]

- Monitoring and Washing:
  - Perform a Kaiser test to confirm the completion of the coupling (a negative result indicates no free primary amines).[1]
  - Drain the coupling solution and wash the resin with DMF (3 times) and DCM (3 times) to remove excess reagents. The resin is now ready for the next deprotection cycle.[12]

## Protocol 2: Solution-Phase Synthesis of Boc-Gly-Gly-OH

This protocol describes a method for synthesizing a dipeptide in solution.

Materials:

- Glycylglycine (H-Gly-Gly-OH)
- Di-tert-butyl dicarbonate ((Boc)<sub>2</sub>O)
- Sodium carbonate (Na<sub>2</sub>CO<sub>3</sub>)
- Tetrahydrofuran (THF)
- Ethyl acetate
- Concentrated hydrochloric acid (HCl)

Procedure:

- Dissolution: Dissolve glycylglycine (0.050 mol) in a 10% aqueous sodium carbonate solution (56 mL).[13]
- Boc Protection: While maintaining the temperature at 20°C, add a solution of (Boc)<sub>2</sub>O (0.0525 mol) in THF (60 mL) dropwise over 30 minutes.[13]
- Reaction: Stir the mixture at 30°C for 2 hours.[13]
- Work-up:

- Transfer the reaction mixture to a separatory funnel and wash with an organic solvent like methyl tertiary-butyl ether to remove excess  $(\text{Boc})_2\text{O}$ . Discard the organic layer.[13]
- Cool the aqueous layer in an ice bath and carefully acidify to pH 3 with concentrated HCl. [13]
- Extraction and Isolation:
  - Extract the product from the acidified aqueous layer with ethyl acetate (100 mL).[13]
  - Wash the organic layer with water.
  - Concentrate the ethyl acetate layer under reduced pressure to precipitate the product as a white solid.[13]
  - Filter and dry the solid to obtain Boc-Gly-Gly-OH.[13]

## Mandatory Visualization

The following diagrams illustrate the logical relationships and workflows described in this guide.

### Principle of Orthogonal Protection

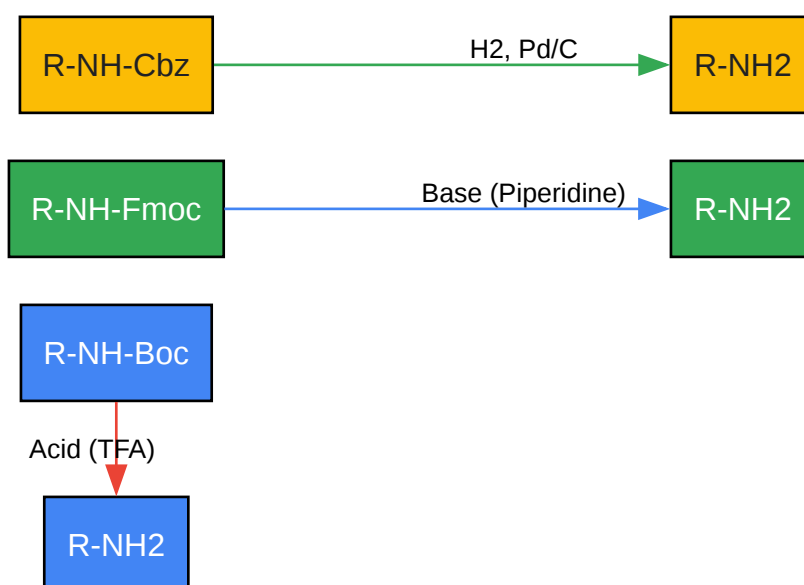

[Click to download full resolution via product page](#)

## Principle of Orthogonal Protection

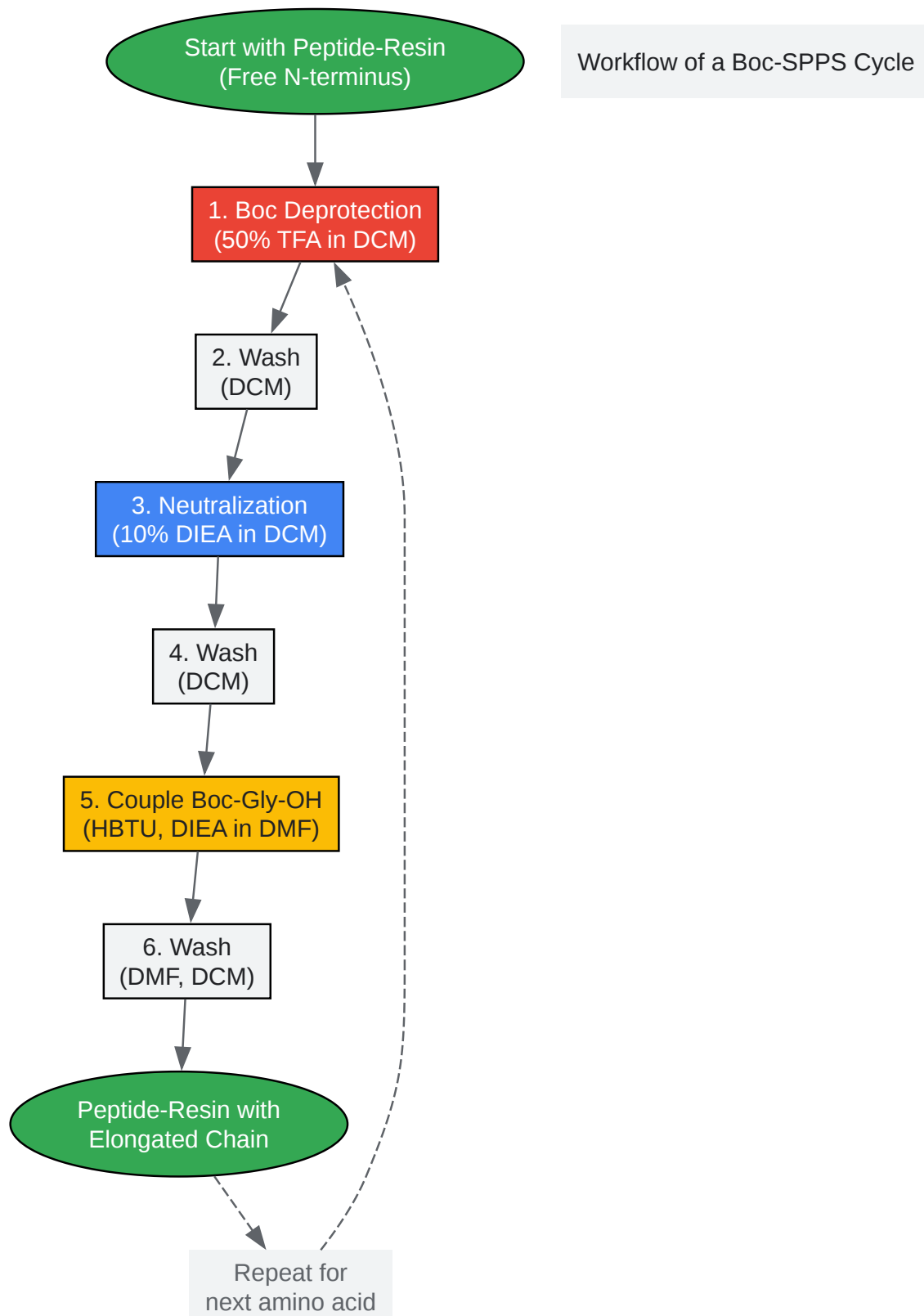

[Click to download full resolution via product page](#)

Workflow of a Boc-SPPS Cycle

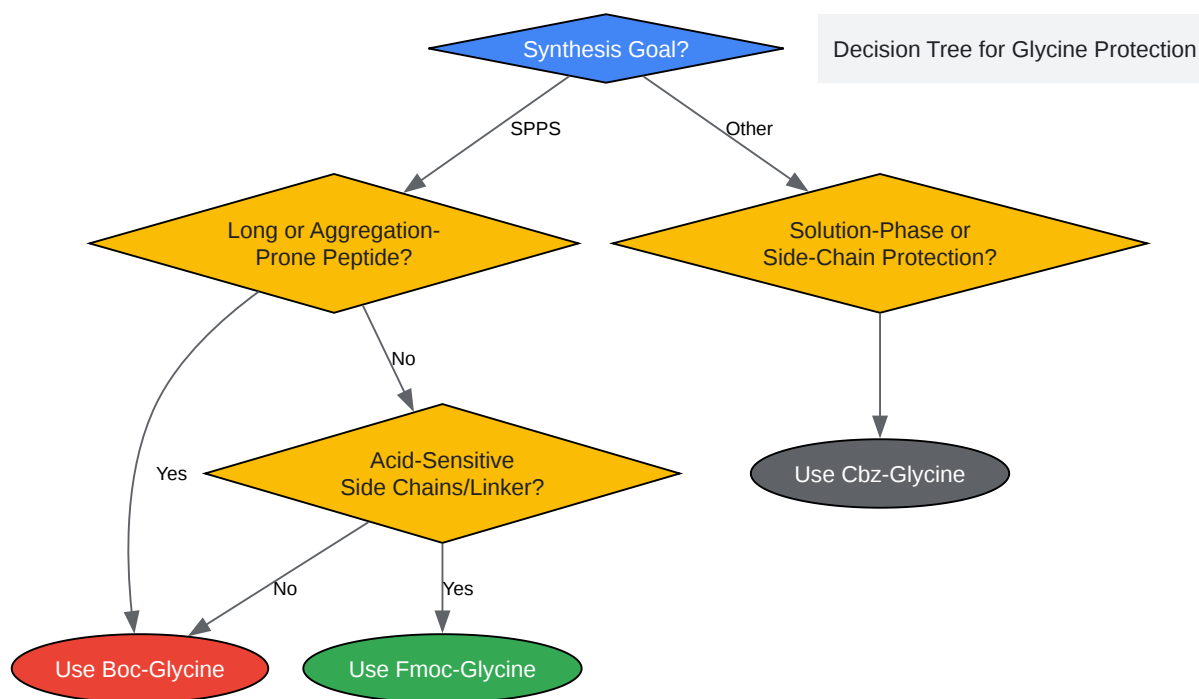

[Click to download full resolution via product page](#)

Decision Tree for Glycine Protection

**Need Custom Synthesis?**

BenchChem offers custom synthesis for rare earth carbides and specific isotopic labeling.

Email: [info@benchchem.com](mailto:info@benchchem.com) or [Request Quote Online](#).

**References**

- [1. benchchem.com \[benchchem.com\]](https://www.benchchem.com)
- [2. benchchem.com \[benchchem.com\]](https://www.benchchem.com)

- 3. [benchchem.com](#) [[benchchem.com](#)]
- 4. [benchchem.com](#) [[benchchem.com](#)]
- 5. [osti.gov](#) [[osti.gov](#)]
- 6. [benchchem.com](#) [[benchchem.com](#)]
- 7. [peptide.com](#) [[peptide.com](#)]
- 8. [peptide.com](#) [[peptide.com](#)]
- 9. [luxembourg-bio.com](#) [[luxembourg-bio.com](#)]
- 10. [bocsci.com](#) [[bocsci.com](#)]
- 11. [benchchem.com](#) [[benchchem.com](#)]
- 12. [benchchem.com](#) [[benchchem.com](#)]
- 13. [benchchem.com](#) [[benchchem.com](#)]
- To cite this document: BenchChem. [A Comparative Guide to Orthogonal Protection Schemes Involving Boc-Glycine]. BenchChem, [2026]. [Online PDF]. Available at: [<https://www.benchchem.com/product/b062520/docs#a-comparative-guide-to-orthogonal-protection-schemes-involving-boc-glycine>]

---

**Disclaimer & Data Validity:**

The information provided in this document is for Research Use Only (RUO) and is strictly not intended for diagnostic or therapeutic procedures. While BenchChem strives to provide accurate protocols, we make no warranties, express or implied, regarding the fitness of this product for every specific experimental setup.

**Technical Support:** The protocols provided are for reference purposes. Unsure if this reagent suits your experiment?

**Need Industrial/Bulk Grade?** [Request Custom Synthesis Quote](#)

# BenchChem

Our mission is to be the trusted global source of essential and advanced chemicals, empowering scientists and researchers to drive progress in science and industry.

## Contact

Address: 3281 E Guasti Rd

Ontario, CA 91761, United States

Phone: (601) 213-4426

Email: [info@benchchem.com](mailto:info@benchchem.com)

[Contact our Ph.D. Support Team for a compatibility check](#)