

Technical Guide: MS Fragmentation Pattern of 8-Bromo-4-chloroquinoline-2-carbaldehyde

Author: BenchChem Technical Support Team. **Date:** April 2026

Compound of Interest

Compound Name: 8-bromo-4-chloroquinoline-2-carbaldehyde

CAS No.: 904369-77-3

Cat. No.: B6195543

[Get Quote](#)

Executive Summary & Structural Context[1][2][3]

- Target Molecule: **8-bromo-4-chloroquinoline-2-carbaldehyde**
- Molecular Formula: C₁₀H₅BrClNO
- Monoisotopic Mass: 268.92 Da (calculated for ⁷⁹Br, ³⁵Cl)
- Application: Key scaffold for antimalarial and anticancer kinase inhibitors.
- Analytical Challenge: Distinguishing the tri-substituted core from mono-halogenated impurities (e.g., des-bromo or des-chloro byproducts) during synthesis.

Comparison of Ionization "Performance"

The choice of ionization method dictates the visible spectral landscape.

Feature	Electron Ionization (EI)	Electrospray Ionization (ESI)
Energy Regime	Hard Ionization (70 eV)	Soft Ionization
Primary Signal	Fragment ions (Structural Fingerprint)	Molecular Ion [M+H] ⁺
Key Utility	Structural Elucidation: Confirms position of halogens via fragmentation hierarchy.	Purity Assay: Best for quantifying the intact parent molecule without inducing breakdown.
Detection Limit	Moderate (Nanogram range)	High (Picogram range)

The Isotopic Fingerprint (Pre-Fragmentation)

Before analyzing fragmentation, the Molecular Ion (M⁺) cluster provides the primary validation of the di-halogenated state. Unlike simple organic molecules, the interaction between Bromine and Chlorine isotopes creates a unique 3:4:1 intensity ratio.

Theoretical Isotope Distribution (M⁺ Cluster)

- ⁷⁹Br: ~50.7% | ⁸¹Br: ~49.3% (Approx 1:1)
- ³⁵Cl: ~75.8% | ³⁷Cl: ~24.2% (Approx 3:1)

m/z Peak	Composition	Relative Intensity (Approx)	Diagnostic Value
269 (M)	⁷⁹ Br + ³⁵ Cl	75%	Base Peak (Nominal Mass)
271 (M+2)	(⁸¹ Br + ³⁵ Cl) + (⁷⁹ Br + ³⁷ Cl)	100%	Dominant Peak (Overlap of isotopes)
273 (M+4)	⁸¹ Br + ³⁷ Cl	25%	Confirms presence of both halogens



Critical Check: If your spectrum shows a 1:1 doublet (M, M+2), you have lost the Chlorine. If you see a 3:1 ratio, you have lost the Bromine. Only a 3:4:1 pattern confirms the 8-bromo-4-chloro motif.

Fragmentation Pathways (EI Mode)

In Electron Ionization (70 eV), the molecule undergoes predictable bond scission. The fragmentation hierarchy is governed by bond dissociation energies (BDE):

- C-C (Aldehyde) < C-Br < C-Cl < C-N (Ring)

Step-by-Step Fragmentation Logic

- Primary Loss (Aldehyde): The aldehyde group at C2 is the most labile. It typically ejects CO (28 Da) or CHO• (29 Da).
 - Transition: m/z 269 → m/z 241 (Loss of CO).
- Secondary Loss (Halogen 1): The C-Br bond is weaker than the C-Cl bond. The fragmentation prefers losing the Bromine radical (Br•, 79/81 Da) first.
 - Transition: m/z 241 → m/z 162.
 - Note: The resulting ion (m/z 162) will now display a 3:1 isotope pattern (characteristic of the remaining Chlorine).
- Tertiary Loss (Halogen 2): Loss of the Chlorine radical (Cl•, 35/37 Da).
 - Transition: m/z 162 → m/z 127.
 - Result: The bare quinoline fragment (C₉H₅N⁺).
- Ring Collapse: The quinoline ring typically ejects HCN (27 Da).

- Transition: m/z 127 \rightarrow m/z 100.

Visualized Pathway (DOT Diagram)

The following diagram maps the specific mass transitions.

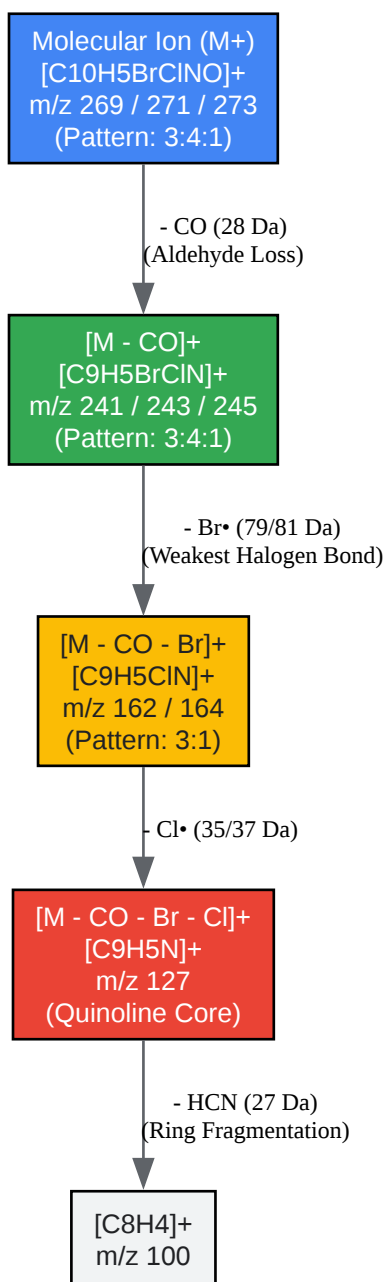

[Click to download full resolution via product page](#)

Caption: Predicted fragmentation pathway for **8-bromo-4-chloroquinoline-2-carbaldehyde** in EI-MS.

Experimental Protocol for Validation

To reproduce these results, use the following standardized acquisition parameters.

Method: GC-MS (Electron Ionization)

This protocol is optimized to detect the molecular ion while inducing sufficient fragmentation for structural confirmation.

- Sample Preparation:
 - Dissolve 1 mg of sample in 1 mL Dichloromethane (DCM) (HPLC Grade).
 - Why DCM? High solubility for halogenated quinolines; low boiling point ensures rapid solvent venting.
- Inlet Conditions:
 - Temperature: 250°C.
 - Mode: Splitless (0.5 min) then 20:1 Split.
- Column:
 - Type: 5% Phenyl-methylpolysiloxane (e.g., HP-5ms or DB-5ms).
 - Dimensions: 30m × 0.25mm × 0.25µm.
- Oven Program:
 - Initial: 100°C (Hold 1 min).
 - Ramp: 20°C/min to 280°C.
 - Hold: 5 min.
 - Rationale: High ramp rate prevents thermal degradation of the aldehyde prior to ionization.
- MS Source:

- Temp: 230°C.
- Energy: 70 eV.
- Scan Range: m/z 50 – 400.

Comparative Data Table

Use this table to interpret your specific spectral peaks.

Fragment Ion	m/z (Monoisotopic)	Expected Isotope Pattern	Structural Assignment
[M] ⁺	268.9	3:4:1 (Br + Cl)	Parent Molecule
[M - H] ⁺	267.9	3:4:1	Aldehyde proton loss (Minor)
[M - CO] ⁺	240.9	3:4:1 (Br + Cl)	Decarbonylation (Base Peak candidate)
[M - CO - Br] ⁺	162.0	3:1 (Cl only)	Loss of Bromine (8-pos)
[M - CO - Cl] ⁺	206.0	1:1 (Br only)	Loss of Chlorine (4-pos) - Less likely than Br loss
[M - CO - Br - Cl] ⁺	127.0	None	Quinoline radical cation
[C ₈ H ₄] ⁺	100.0	None	Loss of HCN from quinoline core

References

- NIST Mass Spectrometry Data Center. "Mass spectrum of 4-Chloroquinoline." NIST Chemistry WebBook, SRD 69. [[Link](#)]

- Save My Exams. "Mass Spectrometry Fragmentation Patterns: Halogenated Compounds." IB Chemistry Revision. [[Link](#)]
- Chemistry LibreTexts. "Fragmentation Patterns of Aldehydes and Aromatics." [[Link](#)]
- To cite this document: BenchChem. [Technical Guide: MS Fragmentation Pattern of 8-Bromo-4-chloroquinoline-2-carbaldehyde]. BenchChem, [2026]. [Online PDF]. Available at: [<https://www.benchchem.com/product/b6195543/docs#technical-guide-ms-fragmentation-pattern-of-8-bromo-4-chloroquinoline-2-carbaldehyde>]

Disclaimer & Data Validity:

The information provided in this document is for Research Use Only (RUO) and is strictly not intended for diagnostic or therapeutic procedures. While BenchChem strives to provide accurate protocols, we make no warranties, express or implied, regarding the fitness of this product for every specific experimental setup.

Technical Support: The protocols provided are for reference purposes. Unsure if this reagent suits your experiment?

Need Industrial/Bulk Grade? [Request Custom Synthesis Quote](#)

BenchChem

Our mission is to be the trusted global source of essential and advanced chemicals, empowering scientists and researchers to drive progress in science and industry.

Contact

Address: 3281 E Guasti Rd
Ontario, CA 91761, United States
Phone: (601) 213-4426
Email: info@benchchem.com

[Contact our Ph.D. Support Team for a compatibility check](#)

