

# Technical Support Center: 1-Fluoro-2-Iodopropane Stability & Handling

**Author:** BenchChem Technical Support Team. **Date:** May 2026

## Compound of Interest

Compound Name: 1-fluoro-2-iodopropane

CAS No.: 154874-10-9

Cat. No.: B6171701

[Get Quote](#)

## Executive Summary: The "Fragile Link" Architecture

### 1-Fluoro-2-iodopropane (

) represents a unique challenge in organic synthesis.<sup>[1]</sup> Structurally, it combines a robust C–F bond with a labile secondary C–I bond.<sup>[1]</sup> This duality makes it a valuable intermediate (often in radiochemistry or fluorinated drug synthesis) but introduces significant stability issues.<sup>[1]</sup>

The iodine atom, attached to a secondary carbon, is an exceptional leaving group.<sup>[1]</sup> While this promotes desired nucleophilic substitutions, it simultaneously lowers the activation energy for unwanted elimination (dehydroiodination) and homolytic cleavage (radical formation).<sup>[1]</sup>

This guide addresses the three primary failure modes encountered by researchers: Discoloration (Iodine liberation), Pressure Buildup (Elimination), and Yield Loss (Hydrolysis/Competition).<sup>[1]</sup>

## Part 1: Diagnostic Troubleshooting Guide

Issue 1: The Reagent has turned purple or dark brown.

Diagnosis: Photolytic/Thermal Homolysis (Radical Decomposition) The carbon-iodine bond is weak (~50–55 kcal/mol).[1] Exposure to UV light or ambient heat causes homolytic cleavage, generating alkyl radicals and iodine radicals.[1] The iodine radicals recombine to form molecular iodine (

), which acts as an autocatalyst for further decomposition.[1]

Corrective Action:

- Immediate Assessment: If the liquid is opaque brown, purity is likely <90%.[1] Distillation is required.[1]
- Purification Protocol: Perform a vacuum distillation. Do not distill at atmospheric pressure, as the boiling point (~128°C) is high enough to accelerate thermal decomposition.[1]
- Stabilization: Once purified, store over activated copper turnings (stabilizer) to scavenge free iodine.[1]

## Issue 2: Pressure buildup in storage vessels or sealed reaction vials.

Diagnosis: Spontaneous Dehydroiodination (Elimination) Even in the absence of strong bases, secondary alkyl iodides can undergo slow elimination of hydrogen iodide (HI), especially if acidic impurities are present.[1] The resulting products are volatile fluoropropenes (gases at room temperature), which pressurize the headspace.[1]

Reaction:

[1]

Corrective Action:

- Venting: Carefully vent the vessel in a fume hood.
- Acid Neutralization: Wash the organic layer with cold, dilute  
or  
(sodium thiosulfate) to remove HI and

before use.[\[1\]](#)

- Cold Storage: Store at 2–8°C. Elimination rates drop significantly below 10°C.

### Issue 3: Low yields during nucleophilic substitution ( )

Diagnosis: Competition from E2 Elimination Because the iodine is on a secondary carbon, basic nucleophiles (e.g., alkoxides, amines) often act as bases rather than nucleophiles, triggering E2 elimination.[\[1\]](#)

Corrective Action:

- Solvent Switch: Switch to polar aprotic solvents (DMF, DMSO, Acetonitrile) to enhance nucleophilicity over basicity.[\[1\]](#)
- Temperature Control: Lower the reaction temperature. Elimination ( is higher) is favored by heat; Substitution is favored by lower temperatures.[\[1\]](#)
- Nucleophile Selection: Use "soft" nucleophiles (e.g., thiols, azides) rather than "hard" bases if possible.[\[1\]](#)

## Part 2: Deep Dive – Decomposition Pathways

The degradation of **1-fluoro-2-iodopropane** is governed by two competing mechanisms: Homolysis (radical) and Heterolysis (ionic elimination).[\[1\]](#)

### Mechanism 1: Thermal/Photolytic Homolysis

This is the primary storage failure mode.[\[1\]](#)

- Initiation:
- Propagation:
- Autocatalysis:

can act as a Lewis acid, weakening C-I bonds in remaining molecules.[\[1\]](#)

## Mechanism 2: Dehydroiodination (Elimination)

This is the primary reaction failure mode.[1] The loss of HI can yield two isomers via Zaitsev or Hofmann orientation.[1]

- Path A (Thermodynamic): Loss of H from C1 ( ) is electronically disfavored due to the electronegative fluorine, but if it occurs, it forms 1-fluoropropene.[1]
- Path B (Kinetic): Loss of H from C3 ( ) is statistically more likely (3 hydrogens vs 2) and less sterically/electronically hindered, forming 3-fluoropropene (Allyl fluoride).[1]

### Pathway Visualization

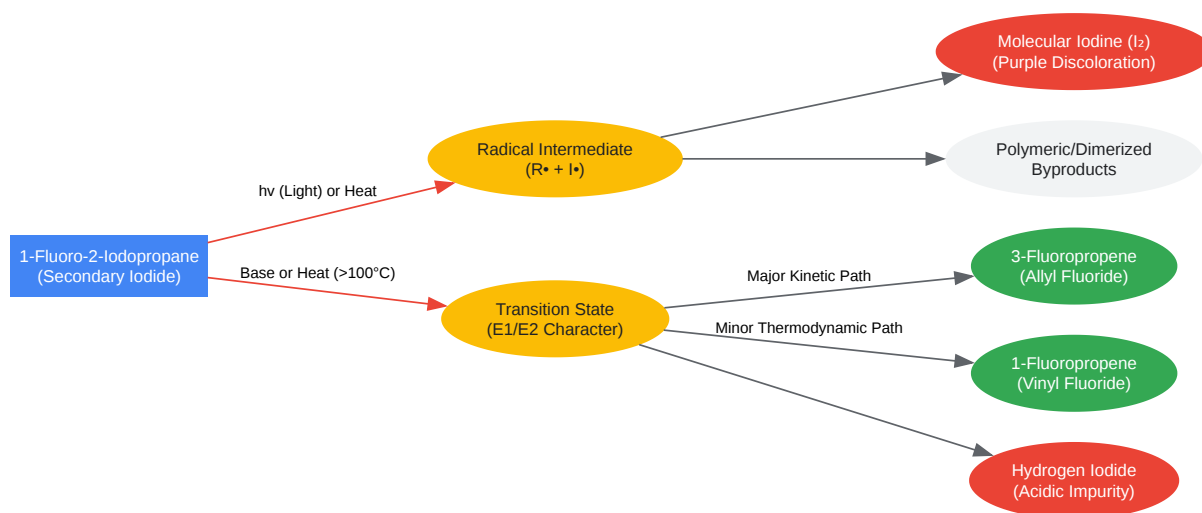

[Click to download full resolution via product page](#)

Figure 1: Divergent decomposition pathways showing the split between radical degradation (storage instability) and elimination (reaction instability).[1]

## Part 3: Experimental Protocols

### Protocol A: Purification via Vacuum Distillation

Required when reagent shows significant discoloration (

decomposition).<sup>[1]</sup>

Parameter	Specification	Notes
Apparatus	Short-path distillation head	Minimize surface area to reduce thermal stress. <sup>[1]</sup>
Pressure	15–20 mmHg (Water aspirator or pump)	Crucial: Do not distill at atm pressure (128°C). <sup>[1]</sup>
Bath Temp	50–60°C	Keep as low as possible.
Collection	40–45°C (at 20 mmHg)	Discard first 5% (forerun) containing volatile fluoropropenes. <sup>[1]</sup>
Receiver	Cooled (-78°C or Ice/Salt)	Prevents loss of product to vacuum trap. <sup>[1]</sup>

### Protocol B: Chemical Stabilization (Copper Method)

Standard industry practice for long-term storage of alkyl iodides.<sup>[1]</sup>

- Preparation: Obtain high-surface-area copper (turnings or powder).<sup>[1]</sup>
- Activation: Wash copper with dilute HCl to remove oxide layer, rinse with water, then acetone, and dry under vacuum.<sup>[1]</sup>
- Addition: Add activated copper to the storage vial (approx. 1-2% by weight of the iodide).
- Mechanism:  
  
. The copper reacts with free iodine, preventing the autocatalytic cycle described in Mechanism 1.<sup>[1]</sup>

## Part 4: Troubleshooting Logic Tree

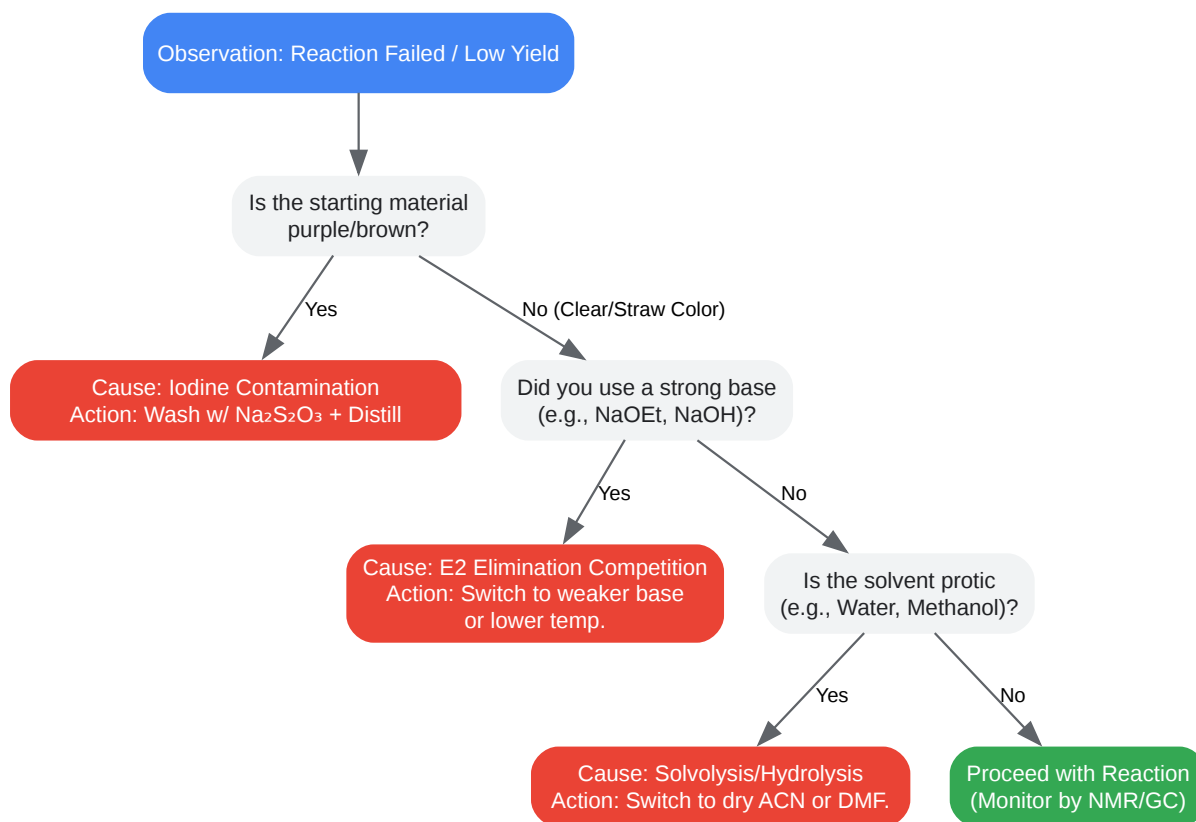

[Click to download full resolution via product page](#)

Figure 2: Decision matrix for diagnosing reaction failures involving **1-fluoro-2-iodopropane**.

## References

- Tokyo Chemical Industry (TCI). (2024).[1] Product Specification: 1-Fluoro-3-iodopropane (Stabilized with Copper chip).[1][2][3][4] (Note: Analogous stability data for fluoro-iodopropanes).[1] [Link](#)
- PubChem. (2024).[1][5] Compound Summary: **1-Fluoro-2-iodopropane**.[1][5] National Center for Biotechnology Information.[1] [Link](#)[1]

- Clark, J. (2023).[1] Elimination Reactions of Halogenoalkanes.[1] Chemistry LibreTexts.[1] (Mechanistic grounding for secondary iodide elimination). [Link](#)
- P2 InfoHouse. (1995).[1] Thermal Stabilities of Fluoroiodocarbons (FICs).[1][6] (Data on C-I bond instability in fluorinated chains). [Link](#)

### Need Custom Synthesis?

BenchChem offers custom synthesis for rare earth carbides and specific isotopic labeling.

Email: [info@benchchem.com](mailto:info@benchchem.com) or [Request Quote Online](#).

## Sources

- 1. [m.youtube.com](https://m.youtube.com) [[m.youtube.com](https://m.youtube.com)]
- 2. [chembk.com](https://chembk.com) [[chembk.com](https://chembk.com)]
- 3. 1-Fluoro-3-iodopropane | 462-40-8 | Tokyo Chemical Industry UK Ltd. [[tcichemicals.com](https://tcichemicals.com)]
- 4. 1-Fluoro-3-iodopropane | 462-40-8 | TCI AMERICA [[tcichemicals.com](https://tcichemicals.com)]
- 5. 1-Fluoro-2-iodopropane | C<sub>3</sub>H<sub>6</sub>FI | CID 20029253 - PubChem [[pubchem.ncbi.nlm.nih.gov](https://pubchem.ncbi.nlm.nih.gov)]
- 6. Thermal Stabilities of Fluoroiodocarbons (FICs) [[p2infohouse.org](https://p2infohouse.org)]
- To cite this document: BenchChem. [Technical Support Center: 1-Fluoro-2-Iodopropane Stability & Handling]. BenchChem, [2026]. [Online PDF]. Available at: [<https://www.benchchem.com/product/b6171701/docs#technical-support-center-1-fluoro-2-iodopropane-stability-handling>]

### Disclaimer & Data Validity:

The information provided in this document is for Research Use Only (RUO) and is strictly not intended for diagnostic or therapeutic procedures. While BenchChem strives to provide accurate protocols, we make no warranties, express or implied, regarding the fitness of this product for every specific experimental setup.

**Technical Support:** The protocols provided are for reference purposes. Unsure if this reagent suits your experiment?

**Need Industrial/Bulk Grade?** [Request Custom Synthesis Quote](#)

## BenchChem

Our mission is to be the trusted global source of essential and advanced chemicals, empowering scientists and researchers to drive progress in science and industry.

### Contact

Address: 3281 E Guasti Rd  
Ontario, CA 91761, United States  
Phone: (601) 213-4426  
Email: [info@benchchem.com](mailto:info@benchchem.com)

[Contact our Ph.D. Support Team for a compatibility check](#)