

Technical Support Center: Minimizing Side Reactions in Thiazole Alkylation

Author: BenchChem Technical Support Team. **Date:** April 2026

Compound of Interest

Compound Name: 5-(chloromethyl)-2-(difluoromethyl)-1,3-thiazole
CAS No.: 2703780-27-0
Cat. No.: B6170964

[Get Quote](#)

Welcome to the technical support center for thiazole alkylation. This guide is designed for researchers, scientists, and drug development professionals to navigate the complexities of this fundamental reaction. Here, you will find in-depth troubleshooting advice and frequently asked questions to help you minimize side reactions and optimize your synthetic outcomes.

Troubleshooting Guide: Common Issues and Solutions

This section addresses specific problems you may encounter during the alkylation of thiazoles, providing explanations for the underlying chemistry and actionable protocols to resolve these issues.

Problem: Poor Regioselectivity - I'm getting a mixture of N- and C-alkylated products.

Q: Why am I observing both N-alkylation and C-alkylation?

A: The regioselectivity of thiazole alkylation is a classic example of kinetic versus thermodynamic control, dictated by the electronic nature of the thiazole ring.[1][2][3]

- N-Alkylation (Kinetic Product): The nitrogen atom (N-3) is the most nucleophilic site due to its lone pair of electrons, making it the initial site of attack by an electrophile.[4][5] This pathway has a lower activation energy and is generally faster, making the N-alkylated product, a thiazolium salt, the kinetic product.[2][3]
- C-Alkylation (Thermodynamic Product): The proton at the C-2 position of the thiazole ring is the most acidic.[4][6] In the presence of a strong base, this proton can be removed to form a carbanion, which is stabilized by the adjacent sulfur atom and the aromatic ring. This carbanion can then react with an alkylating agent to give the C-2 alkylated product. While the formation of the C-2 carbanion has a higher activation energy, the resulting C-alkylated thiazole can be more stable than the corresponding N-alkylated thiazolium salt under certain conditions, making it the thermodynamic product.

The balance between these two pathways is highly dependent on the reaction conditions.

Q: How can I selectively obtain the N-alkylated product?

A: To favor the formation of the N-alkylated thiazolium salt (the kinetic product), you should employ conditions that promote direct alkylation at the nitrogen atom while minimizing deprotonation at C-2.

Recommended Protocol for Selective N-Alkylation:

- Reagent Selection:
 - Alkylating Agent: Use a reactive alkylating agent such as methyl iodide or dimethyl sulfate. [7] For less reactive thiazoles, a more potent agent like methyl triflate may be necessary. [7]
 - Base: Avoid the use of strong bases that can deprotonate the C-2 position. Often, the reaction can proceed without any added base, as the thiazole itself is sufficiently nucleophilic.[4][5] If a base is required to scavenge the acid byproduct, a non-nucleophilic, weak base like proton sponge can be considered.

- Solvent Choice:
 - Select a polar aprotic solvent such as acetonitrile, DMF, or DMSO to facilitate the SN2 reaction and solubilize the resulting thiazolium salt.[7]
- Temperature Control:
 - Run the reaction at a low to moderate temperature (0 °C to room temperature) to favor the kinetic product.[1][3] Higher temperatures can provide enough energy to overcome the activation barrier for C-2 deprotonation and can also lead to an equilibrium favoring the thermodynamic product.[1][8]
- Step-by-Step Procedure:
 1. Dissolve the thiazole substrate in your chosen anhydrous polar aprotic solvent under an inert atmosphere (e.g., nitrogen or argon).
 2. Add the alkylating agent (1.0-1.2 equivalents) dropwise to the stirred solution at the desired temperature (e.g., 0 °C or room temperature).
 3. Monitor the reaction progress by TLC or LC-MS.
 4. Upon completion, the N-alkylated thiazolium salt may precipitate from the solution and can be collected by filtration.[7] If it remains dissolved, the product can often be precipitated by adding a less polar "anti-solvent" like diethyl ether or ethyl acetate.[7]

Problem: My reaction is producing dialkylated products.

Q: I'm observing over-alkylation. What is the cause and how can I prevent it?

A: Over-alkylation, or the formation of dialkylated products, can occur if the initially formed mono-alkylated product can be further alkylated. In the context of thiazoles, this is less common on the ring itself unless there are other nucleophilic sites on the substituents. However, if you are working with a substrate that has multiple nucleophilic centers, you may see dialkylation. For instance, with aminothiazoles, N-alkylation can occur at both the ring nitrogen and the amino group.

Strategies to Minimize Dialkylation:

- **Stoichiometry Control:** Carefully control the stoichiometry of your alkylating agent. Use of a large excess of the alkylating agent can drive the reaction towards dialkylation. Start with a 1:1 molar ratio of your thiazole to the alkylating agent and adjust as needed based on reaction monitoring.
- **Reaction Time and Temperature:** Monitor the reaction closely and stop it as soon as the desired mono-alkylated product is formed. Prolonged reaction times and elevated temperatures can increase the likelihood of over-alkylation.[9]
- **Slow Addition:** Add the alkylating agent slowly to the reaction mixture to maintain a low instantaneous concentration, which can favor mono-alkylation.
- **Protecting Groups:** If your thiazole has other nucleophilic functional groups (like an amino or hydroxyl group), consider using a protecting group strategy to block these sites before performing the N-alkylation.

Problem: I'm working with a thiazole-2-thiol and getting S-alkylation instead of N-alkylation.

Q: Why is my thiazole-2-thiol alkylating on the sulfur atom?

A: Thiazole-2-thiols exist in a tautomeric equilibrium with their corresponding thione form.[10] This creates an ambident nucleophile with two potential sites for alkylation: the exocyclic sulfur atom and the ring nitrogen atom. The regioselectivity of the alkylation is highly dependent on the reaction conditions. S-alkylation is often favored under basic conditions where the thiolate is the dominant nucleophile.

Q: How can I achieve selective N-alkylation of a thiazole-2-thiol?

A: To favor N-alkylation, you need to employ conditions that either enhance the nucleophilicity of the nitrogen atom or selectively promote reaction at that site.

Protocol for Selective N-Alkylation of Thiazole-2-thiols using Phase-Transfer Catalysis:

Phase-transfer catalysis (PTC) is an effective method for directing the alkylation of ambident nucleophiles towards the nitrogen atom.[10]

- Reagents and Materials:
 - Thiazole-2-thiol substrate
 - Alkylating agent (e.g., methyl iodide, benzyl bromide)
 - Anhydrous potassium carbonate (K_2CO_3) as the base
 - Tetrabutylammonium bromide (TBAB) as the phase-transfer catalyst
 - Anhydrous acetonitrile as the solvent
- Step-by-Step Procedure:[\[10\]](#)
 1. To a dry round-bottom flask, add the thiazole-2-thiol (1.0 eq), anhydrous potassium carbonate (2.0 eq), and tetrabutylammonium bromide (0.1 eq).
 2. Add anhydrous acetonitrile to achieve a concentration of 0.1-0.2 M with respect to the thiol.
 3. Stir the suspension at room temperature and add the alkylating agent (1.2 eq) dropwise.
 4. Heat the reaction mixture to reflux (approx. 82°C for acetonitrile).
 5. Monitor the reaction by TLC. The reaction is typically complete within 4-12 hours.
 6. After completion, cool the mixture to room temperature and filter to remove inorganic salts.
 7. Concentrate the filtrate under reduced pressure.
 8. Dissolve the crude product in a suitable organic solvent (e.g., dichloromethane or ethyl acetate), wash with saturated aqueous sodium bicarbonate solution and then with brine.
 9. Dry the organic layer over anhydrous sodium sulfate, filter, and concentrate to yield the crude N-alkylated product.
 10. Purify by column chromatography on silica gel.

Frequently Asked Questions (FAQs)

Q1: What is the general mechanism of thiazole N-alkylation?

A: The N-alkylation of thiazoles is typically a direct alkylation process. The lone pair of electrons on the sp²-hybridized nitrogen atom of the thiazole ring acts as a nucleophile, attacking the electrophilic carbon of the alkylating agent (e.g., an alkyl halide). This reaction proceeds via an SN₂ (bimolecular nucleophilic substitution) mechanism, resulting in the formation of a positively charged N-alkylated thiazolium cation.^{[4][6][7]}

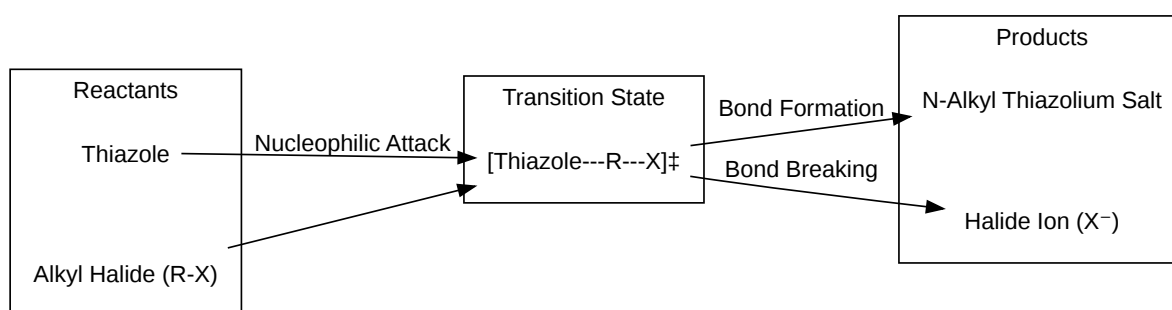

[Click to download full resolution via product page](#)

Caption: General SN₂ mechanism for thiazole N-alkylation.

Q2: How do substituents on the thiazole ring affect the alkylation reaction?

A: Substituents can have a significant impact on the rate and regioselectivity of alkylation through both electronic and steric effects.

- Electron-donating groups (EDGs) at the C2, C4, or C5 positions increase the electron density of the thiazole ring, enhancing the nucleophilicity of the ring nitrogen and thus accelerating the rate of N-alkylation.
- Electron-withdrawing groups (EWGs) decrease the electron density of the ring, making the nitrogen less nucleophilic and slowing down the N-alkylation reaction. In such cases, more

reactive alkylating agents or higher temperatures may be required.

- Steric hindrance from bulky substituents near the N-3 position can impede the approach of the alkylating agent, slowing down the reaction. For instance, a bulky group at the C4 position will have a more pronounced steric effect on N-alkylation than a group at the C5 position.

Substituent Position	Electronic Effect on N-Alkylation Rate	Steric Hindrance
C2	EDG: Increase; EWG: Decrease	Generally low
C4	EDG: Increase; EWG: Decrease	Can be significant
C5	EDG: Increase; EWG: Decrease	Generally low

Q3: What are good general starting conditions for a new thiazole alkylation?

A: For a previously untested thiazole substrate where N-alkylation is the desired outcome, the following conditions provide a robust starting point:

- Substrate: 1.0 equivalent
- Alkylating Agent: Methyl iodide (1.1 equivalents)
- Solvent: Anhydrous acetonitrile or DMF
- Temperature: Room temperature
- Atmosphere: Inert (Nitrogen or Argon)
- Reaction Time: Monitor by TLC or LC-MS, starting checks after 1 hour.

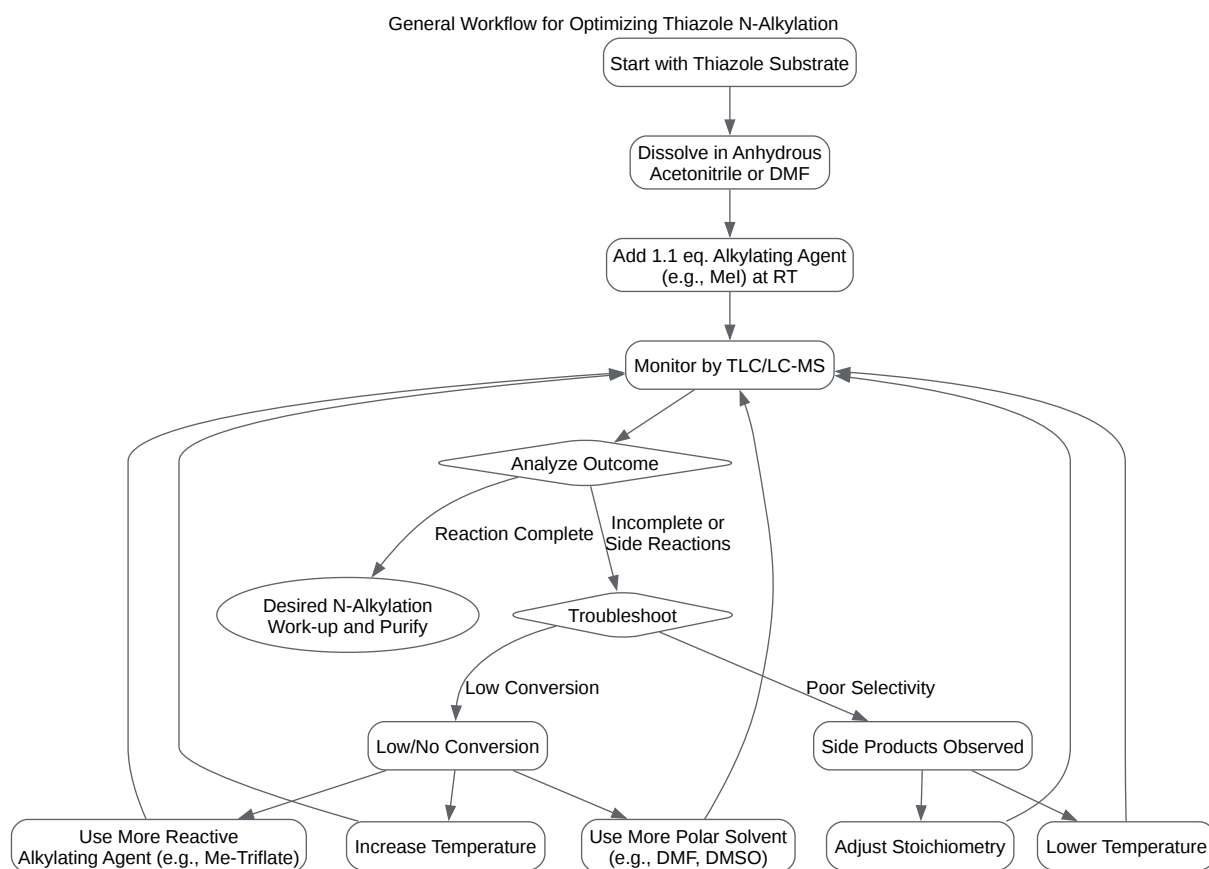

[Click to download full resolution via product page](#)

Caption: Decision workflow for optimizing thiazole N-alkylation reactions.

Q4: How should I work up and purify the resulting thiazolium salts?

A: Thiazolium salts are ionic and often highly polar, which requires different handling compared to neutral organic molecules.[7]

- Isolation: If the thiazolium salt precipitates during the reaction, it can be isolated by simple filtration and washed with a solvent in which it is insoluble (e.g., diethyl ether or cold acetonitrile). If the product is soluble in the reaction solvent, addition of an "anti-solvent" (a less polar solvent in which the salt is insoluble) can induce precipitation.[7]
- Purification:
 - Recrystallization: If a suitable solvent system can be found, recrystallization is an excellent method for purifying solid thiazolium salts.
 - Washing/Trituration: Washing the solid product with a solvent that dissolves impurities but not the salt can be very effective.
 - Chromatography: Standard silica gel chromatography can be challenging due to the high polarity of thiazolium salts. If chromatography is necessary, reversed-phase silica (C18) or specialized polar stationary phases may be required.

Always characterize the final product thoroughly using techniques such as NMR, Mass Spectrometry, and elemental analysis to confirm its structure and purity.

References

- Pharmaguideline. (n.d.). Synthesis, Reactions and Medicinal Uses of Thiazole. Retrieved from [\[Link\]](#)
- Wikipedia. (2023, October 27). Thiazole. Retrieved from [\[Link\]](#)
- Encyclopedia.pub. (2021, March 29). Thiazoles and Bisthiazoles. Retrieved from [\[Link\]](#)
- ResearchGate. (n.d.). Scheme 14. Alkylation of thiazole 24. Reagents and conditions: i. LDA,.... Retrieved from [\[Link\]](#)

- ResearchGate. (n.d.). Synthesis of thiazolium salts and their screening for catalytic activity. Retrieved from [[Link](#)]
- RSC Publishing. (2023). Synthesis and Structure Determination of Substituted Thiazole Derivatives as EGFR/BRAFV600E Dual Inhibitors Endowed with Antiproliferative Activity. Retrieved from [[Link](#)]
- Organic Chemistry Portal. (n.d.). Thiazole synthesis. Retrieved from [[Link](#)]
- Scribd. (n.d.). Thiazole is an aromatic five membered heterocyclic compound having sulphur and ní- trogen at 1 and 3 position. Retrieved from [[Link](#)]
- ResearchGate. (n.d.). General Synthetic Methods for Thiazole and Thiazolium Salts. Retrieved from [[Link](#)]
- ResearchGate. (n.d.). (PDF) Regioselectivity of the alkylation of S-substituted 1,2,4-triazoles with dihaloalkanes. Retrieved from [[Link](#)]
- ResearchGate. (n.d.). Optimizing reaction conditions of N-alkylation reaction | Download Table. Retrieved from [[Link](#)]
- ACS Publications. (2022, July 6). Thiazolium Salts as Chalcogen Bond Donors. Crystal Growth & Design. Retrieved from [[Link](#)]
- University of Saskatchewan Library. (n.d.). A Facile Method for the Synthesis of Thiazolium Salts Using P2S5-Py2 Complex and Their Application in Intermolecular Stetter Reactions. Retrieved from [[Link](#)]
- ChemRxiv. (n.d.). A Purification-Free Method for the Synthesis of Thiazolium Salts Using P2S5-Py2 Complex or P4S10. Retrieved from [[Link](#)]
- Stack Exchange. (2016, September 28). Thermodynamic vs kinetic reaction control with radical substitution. Retrieved from [[Link](#)]
- ResearchGate. (n.d.). N-Alkylation of compounds 166 and 169. Retrieved from [[Link](#)]
- Wikipedia. (n.d.). Thermodynamic versus kinetic reaction control. Retrieved from [[Link](#)]

- National Center for Biotechnology Information. (2026, January 9). Design, synthesis, biological evaluation, and in silico studies of novel 1,3-thiazole derivatives. Retrieved from [\[Link\]](#)
- Dalal Institute. (n.d.). Kinetic and Thermodynamic Control. Retrieved from [\[Link\]](#)
- The University of Queensland. (n.d.). Thiazoles in Peptides and Peptidomimetics. UQ eSpace. Retrieved from [\[Link\]](#)
- ACS Publications. (2025, July 21). Precise N-Alkylation via Cs-LTA Zeolites: Mechanistic Insights and Green Catalytic Synthesis of High-Yield BBIT through Ion-Exchange Optimization. Retrieved from [\[Link\]](#)
- MPG.PuRe. (2021, August 2). Regioselective N-alkylation of the 1H-indazole scaffold. Retrieved from [\[Link\]](#)
- Chemistry LibreTexts. (2024, March 17). 14.3: Kinetic vs. Thermodynamic Control of Reactions. Retrieved from [\[Link\]](#)
- Scribd. (n.d.). Kinetic vs Thermodynamic Control in Reactions | PDF. Retrieved from [\[Link\]](#)
- University College Cork. (n.d.). Regioselective N-alkylation of the 1H-indazole scaffold; ring substituent and N-alkylating reagent effects on regioisomeric distribution. Retrieved from [\[Link\]](#)
- Google Patents. (n.d.). US20040019219A1 - N-alkylated thiazolium salts and process for their preparation.
- National Center for Biotechnology Information. (2025, May 13). Versatile Direct (Hetero)Arylation Polymerization of Electro-Deficient Unsubstituted Thiazolo[5,4-d]Thiazole: A Tool to Lower the LUMO Level. Retrieved from [\[Link\]](#)
- National Center for Biotechnology Information. (n.d.). Controlling Regioselectivity in the Enantioselective N-Alkylation of Indole Analogs Catalyzed by Dinuclear Zinc-ProPhenol. Retrieved from [\[Link\]](#)
- FABAD Journal of Pharmaceutical Sciences. (2024, September 21). An Overview of Synthetic Derivatives of Thiazole and Their Role in Therapeutics. Retrieved from [\[Link\]](#)

- National Center for Biotechnology Information. (2025, December 8). Insights on Regioselective Synthesis of Fused Thiazoles: Density Functional Theory Calculations, Local Reactivity Indices, and Molecular Electrostatic Potential Analysis. Retrieved from [\[Link\]](#)
- PubMed. (2014, November 7). Synthesis by direct arylation of thiazole-derivatives: regioisomer configurations-optical properties relationship investigation. Retrieved from [\[Link\]](#)
- Frontiers. (2025, May 6). Design, synthesis, and biological investigation of new thiazole-based derivatives as multi-targeted inhibitors endowed with antiproliferative, antioxidant, and antibacterial properties. Retrieved from [\[Link\]](#)
- MDPI. (2022, June 21). Thiazole: A Versatile Standalone Moiety Contributing to the Development of Various Drugs and Biologically Active Agents. Retrieved from [\[Link\]](#)
- Taylor & Francis Online. (2020, December 6). Review of the synthesis and biological activity of thiazoles. Retrieved from [\[Link\]](#)

Need Custom Synthesis?

BenchChem offers custom synthesis for rare earth carbides and specific isotopic labeling.

Email: info@benchchem.com or [Request Quote Online](#).

Sources

- [1. Thermodynamic and kinetic reaction control - Wikipedia \[en.wikipedia.org\]](#)
- [2. dalalinstitute.com \[dalalinstitute.com\]](#)
- [3. chem.libretexts.org \[chem.libretexts.org\]](#)
- [4. Synthesis, Reactions and Medicinal Uses of Thiazole | Pharmaguideline \[pharmaguideline.com\]](#)
- [5. courseware.cutm.ac.in \[courseware.cutm.ac.in\]](#)
- [6. Thiazole - Wikipedia \[en.wikipedia.org\]](#)
- [7. pdf.benchchem.com \[pdf.benchchem.com\]](#)
- [8. chemistry.stackexchange.com \[chemistry.stackexchange.com\]](#)
- [9. researchgate.net \[researchgate.net\]](#)

- [10. pdf.benchchem.com \[pdf.benchchem.com\]](https://pdf.benchchem.com)
- To cite this document: BenchChem. [Technical Support Center: Minimizing Side Reactions in Thiazole Alkylation]. BenchChem, [2026]. [Online PDF]. Available at: [<https://www.benchchem.com/product/b6170964/docs#technical-support-center-minimizing-side-reactions-in-thiazole-alkylation>]

Disclaimer & Data Validity:

The information provided in this document is for Research Use Only (RUO) and is strictly not intended for diagnostic or therapeutic procedures. While BenchChem strives to provide accurate protocols, we make no warranties, express or implied, regarding the fitness of this product for every specific experimental setup.

Technical Support: The protocols provided are for reference purposes. Unsure if this reagent suits your experiment?

Need Industrial/Bulk Grade? [Request Custom Synthesis Quote](#)

BenchChem

Our mission is to be the trusted global source of essential and advanced chemicals, empowering scientists and researchers to drive progress in science and industry.

Contact

Address: 3281 E Guasti Rd
Ontario, CA 91761, United States
Phone: (601) 213-4426
Email: info@benchchem.com

[Contact our Ph.D. Support Team for a compatibility check](#)