

Technical Support Center: Methoxy Group Stability with Lewis Acids

Author: BenchChem Technical Support Team. **Date:** April 2026

Compound of Interest

Compound Name: *2-chloro-5-methoxy-1,8-naphthyridine*

CAS No.: *1781605-96-6*

Cat. No.: *B6158575*

[Get Quote](#)

Welcome to the technical support center for navigating the complexities of methoxy group stability in the presence of Lewis acids. This guide is designed for researchers, medicinal chemists, and process development scientists who encounter aryl methyl ethers in their synthetic routes. Here, we move beyond simple statements of fact to explore the underlying principles, helping you to make informed decisions, troubleshoot unexpected outcomes, and design robust experimental protocols.

Part 1: Frequently Asked Questions (FAQs) & Foundational Concepts

This section addresses the most common questions regarding the interaction of methoxy groups with Lewis acids.

Q1: Is the methoxy group generally considered stable under Lewis acid conditions?

A: Broadly speaking, the methoxy group (especially on an aromatic ring) is considered a relatively robust functional group. However, its stability is highly conditional and not absolute.

The outcome depends on a delicate balance between the strength of the Lewis acid, temperature, reaction time, and the substrate's electronic and steric properties. While it can withstand many milder Lewis acids, stronger ones are routinely used for its intentional cleavage.[1][2]

Q2: What is the primary mechanism for Lewis acid-mediated methoxy group cleavage?

A: The cleavage of an aryl methyl ether by a Lewis acid (LA) is initiated by the coordination of the electron-deficient Lewis acid to the lone pair of electrons on the methoxy oxygen.[3] This coordination makes the ether oxygen a better leaving group. The subsequent step involves a nucleophilic attack on the methyl group, typically by a halide counter-ion from the Lewis acid, in a process resembling an SN2 reaction.[1][3] This displaces the aryloxy-Lewis acid complex and generates a methyl halide. The final phenol is liberated upon aqueous workup.[3]

Q3: Which Lewis acids are known to cleave methoxy groups, and which are generally considered safe?

A: This is a critical question.

- **Strong Cleaving Agents:** Boron tribromide (BBr_3) is the most notorious and efficient reagent for demethylating aryl methyl ethers, often working at or below room temperature.[4][5][6] Strong Lewis acids like aluminum chloride (AlCl_3) and trimethylsilyl iodide (TMSI, often generated in situ) are also very effective, though they may require higher temperatures.
- **Potentially Cleaving Agents (Condition Dependent):** Lewis acids like boron trichloride (BCl_3), titanium tetrachloride (TiCl_4), and ferric chloride (FeCl_3) can cause demethylation, especially at elevated temperatures or with prolonged reaction times. Their reactivity is often substrate-dependent.
- **Generally Milder/Safer Agents:** Lewis acids like zinc chloride (ZnCl_2), tin tetrachloride (SnCl_4), and indium(III) salts are often used for reactions like Friedel-Crafts acylations on activated rings (like anisole) with minimal cleavage, provided the conditions are carefully controlled (e.g., low temperature, short reaction time).[7][8]

Q4: How does the substrate's structure affect the stability of the methoxy group?

A: Substrate structure plays a significant role:

- **Electronic Effects:** Electron-donating groups on the aromatic ring can increase the electron density on the methoxy oxygen, potentially enhancing its coordination to the Lewis acid and making it more susceptible to cleavage.
- **Steric Hindrance:** Bulky groups ortho to the methoxy group can sterically hinder the approach of the Lewis acid, making the ether linkage more stable.
- **Multiple Methoxy Groups:** In polymethoxyarenes, selective demethylation can sometimes be achieved. The methoxy group that is cleaved is often the one whose cleavage leads to the most stabilized intermediate or is sterically most accessible.

Part 2: Mechanistic Deep Dive: The Demethylation Pathway

Understanding the mechanism is key to controlling the reaction. The cleavage of an aryl methyl ether by a strong Lewis acid like BBr_3 is a classic example.

The process begins with the formation of a Lewis acid-base adduct between the ether oxygen and the boron atom.^{[3][9]} This activates the C-O bond. A bromide ion then acts as a nucleophile, attacking the methyl carbon in an $\text{S}_{\text{N}}2$ fashion to cleave the methyl-oxygen bond.^[3] Recent computational studies suggest a more complex mechanism where one equivalent of BBr_3 can cleave up to three equivalents of anisole through various charged intermediates and bimolecular pathways before final hydrolysis.^{[4][9]}

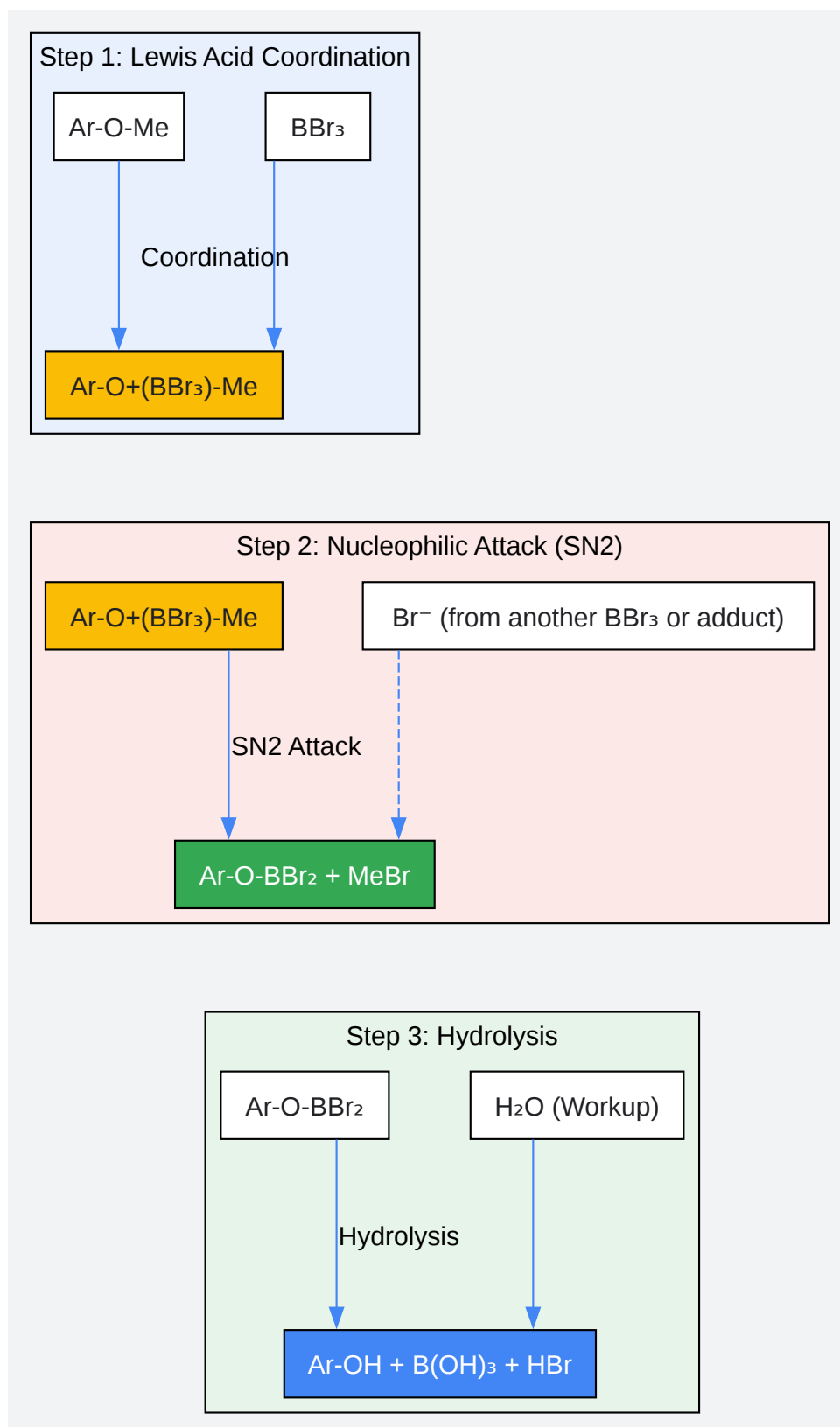

[Click to download full resolution via product page](#)

Caption: Mechanism of BBr₃-mediated ether cleavage.

Part 3: Troubleshooting Guide

Unexpected demethylation can lead to yield loss and purification challenges. This guide helps diagnose and solve common issues.

Observed Problem	Potential Cause(s)	Recommended Action(s)
Partial or complete demethylation of the desired product.	<ol style="list-style-type: none">1. Lewis acid is too strong: The chosen Lewis acid (e.g., AlCl_3) is too harsh for the substrate under the reaction conditions. [2]2. High temperature: Reaction temperature is promoting ether cleavage.3. Prolonged reaction time: Extended exposure to the Lewis acid is causing the side reaction.	<ol style="list-style-type: none">1. Switch to a milder Lewis acid: Try SnCl_4, ZnCl_2, or InCl_3. [7]2. Lower the reaction temperature: Run the reaction at $0\text{ }^\circ\text{C}$ or even $-78\text{ }^\circ\text{C}$ if possible.3. Optimize reaction time: Monitor the reaction by TLC or LC-MS to determine the minimum time required for completion.
Reaction fails to proceed or is very sluggish after switching to a milder Lewis acid.	<ol style="list-style-type: none">1. Insufficient activation: The milder Lewis acid is not strong enough to promote the desired primary reaction (e.g., Friedel-Crafts). [10]2. Poor quality Lewis acid: The Lewis acid may be hydrated or decomposed.	<ol style="list-style-type: none">1. Gradually increase temperature: Cautiously warm the reaction and monitor for product formation vs. demethylation.2. Consider a moderately stronger Lewis acid: Try FeCl_3 or a slight excess of the current Lewis acid.3. Use freshly opened or purified Lewis acid.
Formation of complex mixtures and/or polymer-like material.	<ol style="list-style-type: none">1. Excessive Lewis acid: A large excess of a strong Lewis acid can cause multiple side reactions, including polymerization, especially with activated aromatics like anisole. [6]2. High concentration: Concentrated reaction mixtures can favor intermolecular side reactions.	<ol style="list-style-type: none">1. Reduce Lewis acid stoichiometry: Use catalytic amounts if possible, or reduce the excess to 1.1-1.5 equivalents.2. Dilute the reaction mixture.3. Use inverse addition: Add the Lewis acid to the solution of the substrate and electrophile to maintain a low instantaneous concentration of the acid.

Part 4: Lewis Acid Selection Guide

Choosing the right Lewis acid from the start is crucial for success. This decision tree can guide your selection process.

Caption: Decision tree for Lewis acid selection.

Lewis Acid Reactivity Summary

Lewis Acid	Common Form	Relative Reactivity towards Methoxy Group	Typical Conditions for Preservation	Notes
BBr_3	1.0 M in CH_2Cl_2	Very High (Cleaving Agent)	Not Recommended	The go-to reagent for efficient demethylation. [4] [6]
AlCl_3	Anhydrous solid	High	Risky; use at low temp ($< 0\text{ }^\circ\text{C}$) with short times	Often used in Friedel-Crafts but can easily cause demethylation. [11]
FeCl_3	Anhydrous solid	Moderate	$0\text{ }^\circ\text{C}$ to RT	A milder alternative to AlCl_3 for some acylations. [8]
TiCl_4	Neat liquid or in CH_2Cl_2	Moderate	$\leq 0\text{ }^\circ\text{C}$	Reactivity can be tuned by solvent and temperature. [12]
SnCl_4	Neat liquid or in CH_2Cl_2	Low to Moderate	$\leq 0\text{ }^\circ\text{C}$	Generally a safe choice for Friedel-Crafts on sensitive substrates.
$\text{InCl}_3, \text{In}(\text{OTf})_3$	Solid	Low	RT	Effective and mild catalyst for various transformations. [7]

ZnCl ₂	Anhydrous solid	Very Low	RT to moderate heat	A weak Lewis acid, useful when very mild conditions are required.
-------------------	-----------------	----------	---------------------	---

Part 5: Experimental Protocols

Protocol 1: Methoxy Group Preservation - Friedel-Crafts Acylation of Anisole

This protocol uses a milder Lewis acid to minimize the risk of demethylation during the acylation of anisole.[8]

Objective: Synthesize 4-methoxyacetophenone while preserving the methoxy group.

Materials:

- Anisole
- Acetyl Chloride
- Anhydrous Iron(III) Chloride (FeCl₃)
- Dichloromethane (DCM), anhydrous
- Ice-cold water
- Saturated aqueous NaHCO₃ solution
- Brine
- Anhydrous MgSO₄

Procedure:

- Reaction Setup: To a flame-dried, three-neck round-bottom flask equipped with a magnetic stir bar, nitrogen inlet, and a dropping funnel, add anhydrous FeCl₃ (1.1 eq).

- Add anhydrous DCM via syringe and cool the resulting suspension to 0 °C in an ice bath.
- Add acetyl chloride (1.05 eq) to the suspension and stir for 10 minutes.
- Addition of Anisole: Dissolve anisole (1.0 eq) in a small amount of anhydrous DCM and add it to the dropping funnel. Add the anisole solution dropwise to the reaction mixture over 20-30 minutes, maintaining the internal temperature at 0 °C.
- Reaction Monitoring: Stir the mixture at 0 °C. Monitor the reaction progress by TLC (e.g., 9:1 Hexanes:EtOAc). The reaction is typically complete within 1-2 hours.
- Work-up: Once the reaction is complete, quench it by slowly pouring the mixture into a beaker of vigorously stirred ice-cold water.
- Transfer the mixture to a separatory funnel, separate the layers, and extract the aqueous layer twice with DCM.
- Combine the organic layers and wash sequentially with saturated NaHCO₃ solution (caution: gas evolution), water, and brine.
- Dry the organic layer over anhydrous MgSO₄, filter, and concentrate under reduced pressure to yield the crude product.
- Purification: Purify the crude 4-methoxyacetophenone by recrystallization or flash column chromatography.

Protocol 2: Intentional Methoxy Group Cleavage - Demethylation of 4-Methoxyacetophenone

This protocol uses the standard, highly effective BBr₃ reagent for demethylation.^[6]

Objective: Convert 4-methoxyacetophenone to 4-hydroxyacetophenone.

Materials:

- 4-Methoxyacetophenone
- Boron Tribromide (BBr₃), 1.0 M solution in DCM

- Dichloromethane (DCM), anhydrous
- Methanol
- Deionized Water
- Saturated aqueous NaHCO_3 solution
- 1 M HCl solution

Procedure:

- Reaction Setup: Dissolve 4-methoxyacetophenone (1.0 eq) in anhydrous DCM in a flame-dried, round-bottom flask under a nitrogen atmosphere.
- Cooling: Cool the solution to $-78\text{ }^\circ\text{C}$ using a dry ice/acetone bath.
- Addition of BBr_3 : Slowly add BBr_3 solution (1.2 eq) dropwise via syringe. A color change and/or precipitate may be observed.
- Reaction: Allow the reaction to stir at $-78\text{ }^\circ\text{C}$ for 1 hour, then let it warm slowly to room temperature and stir for an additional 2-4 hours, or until TLC analysis indicates complete consumption of the starting material.
- Quenching: Cool the reaction mixture back down to $0\text{ }^\circ\text{C}$ in an ice bath. Quench the reaction by the very slow, dropwise addition of methanol to destroy excess BBr_3 , followed by the slow addition of water.
- Work-up: Dilute the mixture with additional DCM. Transfer to a separatory funnel and separate the layers. Extract the aqueous layer twice with DCM.
- Combine the organic layers and wash with brine.
- Extract the desired phenol from the organic layer into an aqueous base (e.g., 1 M NaOH).
- Wash the aqueous layer with DCM to remove any non-phenolic impurities.

- Isolation: Acidify the aqueous layer with 1 M HCl until the pH is ~2. The product will often precipitate or can be extracted with ethyl acetate.
- Dry the organic extracts over anhydrous MgSO₄, filter, and concentrate under reduced pressure to yield the purified 4-hydroxyacetophenone.

References

- Lord, R. L., Korich, A. L., et al. (2015). Ether Cleavage Re-Investigated: Elucidating the Mechanism of BBr₃-Facilitated Demethylation of Aryl Methyl Ethers. *European Journal of Organic Chemistry*, 2015(34), 7460-7467. [[Link](#)]
- Lord, R. L., & Korich, A. L. (2015). Supporting Information for Ether Cleavage Re-Investigated: Elucidating the Mechanism of BBr₃-Facilitated Demethylation of Aryl Methyl Ethers. Grand Valley State University ScholarWorks@GVSU. [[Link](#)]
- Westin, J. Cleavage of Ethers. *Organic Chemistry*, Jack Westin. [[Link](#)]
- Common Organic Chemistry. Boron Tribromide (BBr₃) Mechanism - Demethylation of Methyl Ethers. [[Link](#)]
- Campeau, L. C., et al. (2016). Lewis Acid Accelerated Aryl Ether Bond Cleavage with Ni: Orders of Magnitude Rate Enhancement by AlMe₃. *Angewandte Chemie International Edition*, 55(48), 17173-17176. [[Link](#)]
- Ashenhurst, J. (2014). Acidic Cleavage of Ethers. *Master Organic Chemistry*. [[Link](#)]
- Campeau, L. C., et al. (2016). Lewis Acid Accelerated Aryl Ether Bond Cleavage with Nickel: Orders of Magnitude Rate Enhancement Using AlMe₃. *Chemistry – A European Journal*, 22(48), 17173-17176. [[Link](#)]
- Wikipedia. Ether cleavage. [[Link](#)]
- Lee, P. H., Lee, K., & Kim, S. (2008). Remarkably Mild and Efficient Intramolecular Friedel-Crafts Cyclization Catalyzed by In(III). *Organic Letters*, 10(9), 1609-1612. [[Link](#)]
- Sciencemadness Discussion Board. (2014). What is the mechanism for catalytic cleavage of ethers by Lewis Acid's?. [[Link](#)]

- Ale-Kabab, S. (2017). Studies on the Effect of Lewis Acids on Fmoc Deprotection in Solution and Solid-Phase. Electronic Theses and Dissertations. [\[Link\]](#)
- Ashenhurst, J. (2018). Friedel-Crafts Acylation and Alkylation. Master Organic Chemistry. [\[Link\]](#)
- González, C. C., et al. (2006). Selective Cleavage of Methoxy Protecting Groups in Carbohydrates. The Journal of Organic Chemistry, 71(5), 1938-1948. [\[Link\]](#)
- Student Submission. (2006). Friedel-Crafts Acylation of Anisole. Course Hero. [\[Link\]](#)
- Gignac, M. G., & Gagné, M. R. (2013). Selective demethylation of O-aryl glycosides by iridium-catalyzed hydrosilylation. Chemical Communications, 49(59), 6668-6670. [\[Link\]](#)
- ResearchGate. (2019). Lewis Acid Catalyzed Friedel—Crafts Acylation Reaction Using Carboxylic Acids as Acylating Agents. [\[Link\]](#)
- Finnegan, R. A., & Mueller, W. H. (1978). Selective demethylation of polymethoxyxanthenes with aqueous piperidine. Journal of Pharmaceutical Sciences, 67(9), 1321-1322. [\[Link\]](#)
- Wikipedia. Lewis acids and bases. [\[Link\]](#)
- ResearchGate. (2016). Lewis Acid Accelerated Aryl Ether Bond Cleavage with Ni: Orders of Magnitude Rate Enhancement by AlMe₃. [\[Link\]](#)
- González, C. C., et al. (2006). Selective Cleavage of Methoxy Protecting Groups in Carbohydrates. Figshare. [\[Link\]](#)
- Blucher Proceedings. (2013). Study of the ortho-methoxy substituent group effect in selective demethylation reactions of methoxybenzoic acids. [\[Link\]](#)
- ResearchGate. (2019). Orienting methoxy group-carbocation conjugation effects explaining the... [\[Link\]](#)
- ResearchGate. (2006). Efficient and Selective Removal of Methoxy Protecting Groups in Carbohydrates. [\[Link\]](#)

- Ramachandran, P. V., Alawaed, A. A., & Hamann, H. J. (2023). Balancing Lewis Acidity and Carbocation Stability for the Selective Deoxyhalogenation of Aryl Carbonyls and Carbinols. Organic Chemistry Portal. [[Link](#)]
- Hanson, J. T. (2010). Preparation and Applications of 4-Methoxybenzyl Esters in Organic Synthesis. Molecules, 15(4), 2663-2673. [[Link](#)]
- Gignac, M. G., & Gagné, M. R. (2013). Selective demethylation of O-aryl glycosides by iridium-catalyzed hydrosilylation. Chemical Communications, 49(59), 6668-6670. [[Link](#)]
- Google Patents. (2006). Process for regioselective demethylation of p-methoxy group in phenolic ester and diaryl ketone moieties.
- Patsnap Eureka. (2025). Lewis Acid Stability in Extreme Reaction Conditions. [[Link](#)]
- Humadi, S. A. J., Mohammed, L. A., & Hassan, E. A. (2018). Further Evidence of the Relative Stability Evaluation of Lewis Acid Base Complexes. Diyala Journal of Pure Science, 14(2), 88-103. [[Link](#)]
- Zhang, Y., et al. (2020). Lewis-Acid Mediated Reactivity in Single-Molecule Junctions. Journal of the American Chemical Society, 142(30), 13028-13036. [[Link](#)]

Need Custom Synthesis?

BenchChem offers custom synthesis for rare earth carbides and specific isotopic labeling.

Email: info@benchchem.com or [Request Quote Online](#).

Sources

- [1. jackwestin.com](http://jackwestin.com) [jackwestin.com]
- [2. masterorganicchemistry.com](http://masterorganicchemistry.com) [masterorganicchemistry.com]
- [3. pdf.benchchem.com](http://pdf.benchchem.com) [pdf.benchchem.com]
- [4. Ether Cleavage Re-Investigated: Elucidating the Mechanism of BBr₃-Facilitated Demethylation of Aryl Methyl Ethers - PubMed](https://pubmed.ncbi.nlm.nih.gov/) [pubmed.ncbi.nlm.nih.gov]
- [5. Boron Tribromide \(BBr₃\) Mechanism - Demethylation of Methyl Ethers](http://commonorganicchemistry.com) [commonorganicchemistry.com]

- [6. chemistry.mdma.ch \[chemistry.mdma.ch\]](#)
- [7. Remarkably Mild and Efficient Intramolecular Friedel-Crafts Cyclization Catalyzed by In\(III\) - PMC \[pmc.ncbi.nlm.nih.gov\]](#)
- [8. pdf.benchchem.com \[pdf.benchchem.com\]](#)
- [9. "Ether Cleavage Re-Investigated: Elucidating the Mechanism of BBr₃- Fac" by Richard L. Lord, Andrew L. Korich et al. \[scholarworks.gvsu.edu\]](#)
- [10. masterorganicchemistry.com \[masterorganicchemistry.com\]](#)
- [11. condor.depaul.edu \[condor.depaul.edu\]](#)
- [12. Balancing Lewis Acidity and Carbocation Stability for the Selective Deoxyhalogenation of Aryl Carbonyls and Carbinols \[organic-chemistry.org\]](#)
- To cite this document: BenchChem. [Technical Support Center: Methoxy Group Stability with Lewis Acids]. BenchChem, [2026]. [Online PDF]. Available at: [\[https://www.benchchem.com/product/b6158575/docs#technical-support-center-methoxy-group-stability-with-lewis-acids\]](https://www.benchchem.com/product/b6158575/docs#technical-support-center-methoxy-group-stability-with-lewis-acids)

Disclaimer & Data Validity:

The information provided in this document is for Research Use Only (RUO) and is strictly not intended for diagnostic or therapeutic procedures. While BenchChem strives to provide accurate protocols, we make no warranties, express or implied, regarding the fitness of this product for every specific experimental setup.

Technical Support: The protocols provided are for reference purposes. Unsure if this reagent suits your experiment?

Need Industrial/Bulk Grade? [Request Custom Synthesis Quote](#)

BenchChem

Our mission is to be the trusted global source of essential and advanced chemicals, empowering scientists and researchers to drive progress in science and industry.

Contact

Address: 3281 E Guasti Rd
Ontario, CA 91761, United States
Phone: (601) 213-4426
Email: info@benchchem.com

Contact our Ph.D. Support Team for a compatibility check