

# avoiding polymerization of reactive chloromethyl heterocycles

**Author:** BenchChem Technical Support Team. **Date:** April 2026

## Compound of Interest

Compound Name: *4-(chloromethyl)pyridazine hydrochloride*  
CAS No.: *50901-48-9*  
Cat. No.: *B6151622*

[Get Quote](#)

Welcome to the Heterocycle Process Safety & Stability Center. Ticket ID: #POLY-CL-HET-001 | Status: Open | Priority: Critical

Subject: Preventing Polymerization of Reactive Chloromethyl Heterocycles Assigned Specialist: Dr. A. V. Thorne, Senior Application Scientist

## Executive Summary

You are encountering "black tar" formation because chloromethyl heterocycles (e.g., 4-(chloromethyl)pyridine, 2-(chloromethyl)thiazoles) are "Janus" molecules: they contain both a nucleophile (the ring nitrogen) and an electrophile (the chloromethyl group).

In their free-base form, they undergo intermolecular self-quaternization, creating an autocatalytic polymerization cascade. This guide provides the protocols to break this cycle by managing protonation states and concentration kinetics.

## Module 1: The Mechanism of Failure

Understanding why your reagent turns into a brick.

The root cause is a bimolecular nucleophilic substitution (

) where one molecule attacks another. This forms a dimer, which is still nucleophilic, leading to an "ionene" polymer (a polyelectrolyte).

Key Risk Factor: The reaction is second-order with respect to concentration.

Implication: Doubling the concentration quadruples the polymerization rate.

## Visualizing the Polymerization Pathway

The following diagram illustrates the self-quaternization of 4-(chloromethyl)pyridine.

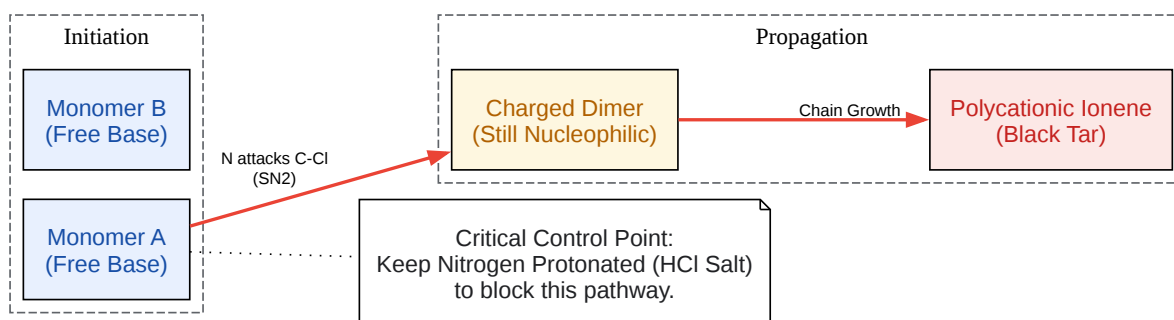

[Click to download full resolution via product page](#)

Figure 1: Mechanism of self-quaternization leading to insoluble ionene polymers.

## Module 2: Storage & Stability Protocols

### The Golden Rule: Store as the Salt

Never store reactive chloromethyl heterocycles as free bases.

- Stable Form: Hydrochloride salt (e.g., 4-(chloromethyl)pyridine·HCl). The protonated nitrogen is non-nucleophilic, rendering the molecule inert to itself [1].

- **Storage Conditions:** Desiccator at  $<4^{\circ}\text{C}$ . These salts are hygroscopic; moisture can induce hydrolysis to the alcohol (hydroxymethyl), releasing HCl and potentially triggering autocatalysis.

Reagent Form	Stability	Handling Recommendation
HCl Salt	High (Years)	Store dry at $4^{\circ}\text{C}$ . Handle freely on the bench.
Free Base (Solid)	Critical ( $<1$ hour)	Do not isolate. Polymerizes exothermically.
Free Base (Solution)	Moderate (Hours)	Keep dilute ( $<0.1$ M) in non-polar solvents at $-20^{\circ}\text{C}$ .

## Module 3: Experimental Workflows

### Protocol A: The "In-Situ" Neutralization (Recommended)

Use this for coupling reactions (e.g., reacting chloromethylpyridine with amines, thiols, or phenols).

**Concept:** You generate the unstable free base only in the presence of the target nucleophile. The target nucleophile (present in excess or higher reactivity) intercepts the chloromethyl species before it can find another chloromethyl molecule.

Step-by-Step:

- **Suspension:** Suspend the Chloromethyl Heterocycle·HCl salt in the reaction solvent (e.g., DMF,  $\text{CH}_3\text{CN}$ ).
- **Target Addition:** Add your Target Nucleophile (1.0 - 1.2 equivalents).
- **Controlled Deprotonation:** Add a non-nucleophilic base (e.g., DIPEA, TEA, or  $\text{K}_2\text{CO}_3$ ) dropwise or in portions.
  - **Why?** This releases the free base slowly. The concentration of "Free Chloromethyl Heterocycle" never spikes, favoring the cross-reaction over self-polymerization.

## Protocol B: The Cold-Trap Isolation (High Risk)

Use this ONLY if your subsequent reaction cannot tolerate the amine base salts formed in Protocol A.

- Cooling: Chill a biphasic mixture of DCM (Dichloromethane) and saturated aq. NaHCO<sub>3</sub> to 0°C.
- Neutralization: Add the Chloromethyl·HCl salt to the mixture with vigorous stirring.
- Extraction: Separate layers quickly. Wash organic layer with cold brine.
- Drying: Dry over MgSO<sub>4</sub> at 0°C for <10 mins.
- Storage: Do not rotary evaporate to dryness. The concentration step is where polymerization explodes. Use the solution directly or concentrate only partially (keep >5 volumes of solvent).

## Workflow Visualization

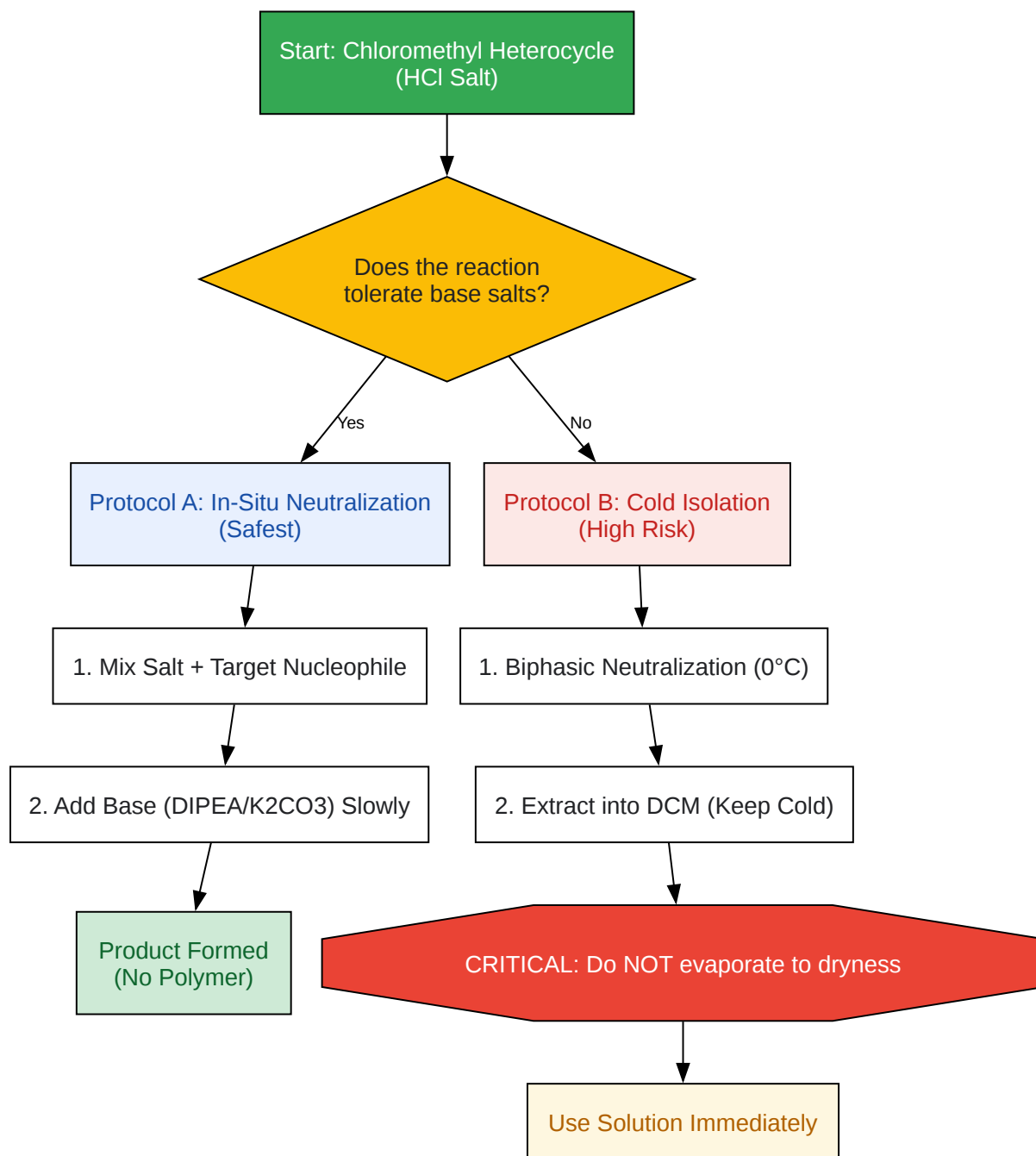

[Click to download full resolution via product page](#)

Figure 2: Decision tree for handling reactive chloromethyl heterocycles.

## Module 4: Troubleshooting & FAQs

Q1: I followed the protocol, but my yield is low and the product is purple/black. Why? A: You likely have trace moisture or high temperature.

- **Diagnosis:** Even if you avoid polymerization, these compounds hydrolyze easily to the alcohol (hydroxymethyl), which is often an oil that oxidizes to colored impurities.
- **Fix:** Use anhydrous solvents. Keep the reaction  $<25^{\circ}\text{C}$ . If heating is required for the coupling, ensure the "Target Nucleophile" is in large excess (2-3 equivalents) to outcompete self-reaction.

Q2: Can I use 2-(chloromethyl)pyridine instead of the 4-isomer? A: Yes, but be aware of the electronic differences.

- **4-isomer:** Nitrogen is highly nucleophilic; polymerization is very fast.
- **2-isomer:** Steric hindrance near the nitrogen slightly slows down dimerization, but it is still unstable.
- **3-isomer:** The nitrogen is not conjugated to the chloromethyl group in the same way, making the C-Cl bond less labile (slower reaction), but the nitrogen is still nucleophilic.
- **Rule of Thumb:** Treat all chloromethyl pyridines/quinolines as "bomb threats" regarding polymerization [2].

Q3: Which solvent is best to suppress polymerization? A: Non-polar solvents (DCM, Toluene, Ether). Polymerization involves the formation of charged species (ions) from neutral molecules.

- **Polar solvents (DMF, DMSO, Water):** Stabilize the transition state (charge separation), accelerating polymerization.
- **Non-polar solvents:** Destabilize the charged transition state, slowing polymerization.
- **Tip:** If you must use DMF for solubility, keep the temperature strictly controlled ( $0^{\circ}\text{C}$ ).

Q4: Is the "black tar" dangerous? A: It is generally non-explosive but is a potent alkylating agent. The polymer (poly-vinylpyridinium or similar) effectively traps chloride ions. It is difficult

to clean.

- Cleaning Tip: The tar is often insoluble in organic solvents but soluble in strong aqueous acid (re-protonating the polymer backbone) or oxidizing cleaning baths (Piranha solution - use extreme caution).

## References

- Sigma-Aldrich. (n.d.). 4-(Chloromethyl)pyridine hydrochloride Product Sheet. Retrieved from
- PubChem. (2025).[1] 4-(Chloromethyl)pyridine Compound Summary. National Library of Medicine. Retrieved from
- Milbank, B. J., et al. (2009).[2] Synthesis and evaluation of stable bidentate transition metal complexes.... Journal of Medicinal Chemistry. (Discusses stability of chloromethyl intermediates). Retrieved from
- Santa Cruz Biotechnology. (n.d.).[3] 4-(Chloromethyl)pyridine hydrochloride Safety Data Sheet. Retrieved from

### Need Custom Synthesis?

BenchChem offers custom synthesis for rare earth carbides and specific isotopic labeling.

Email: [info@benchchem.com](mailto:info@benchchem.com) or [Request Quote Online](#).

## Sources

- 1. 4-(Chloromethyl)pyridine | C6H6ClN | CID 74571 - PubChem [[pubchem.ncbi.nlm.nih.gov](https://pubchem.ncbi.nlm.nih.gov)]
- 2. Synthesis and evaluation of stable bidentate transition metal complexes of 1-(chloromethyl)-5-hydroxy-3-(5,6,7-trimethoxyindol-2-ylcarbonyl)-2,3-dihydro-1H-pyrrolo[3,2-f]quinoline (seco-6-azaCBI-TMI) as hypoxia selective cytotoxins - PubMed [[pubmed.ncbi.nlm.nih.gov](https://pubmed.ncbi.nlm.nih.gov)]
- 3. 4-(Chloromethyl)pyridine hydrochloride | CAS 1822-51-1 | SCBT - Santa Cruz Biotechnology [[scbt.com](https://scbt.com)]
- To cite this document: BenchChem. [avoiding polymerization of reactive chloromethyl heterocycles]. BenchChem, [2026]. [Online PDF]. Available at:

[<https://www.benchchem.com/product/b6151622/docs#avoiding-polymerization-of-reactive-chloromethyl-heterocycles>]

### Disclaimer & Data Validity:

The information provided in this document is for Research Use Only (RUO) and is strictly not intended for diagnostic or therapeutic procedures. While BenchChem strives to provide accurate protocols, we make no warranties, express or implied, regarding the fitness of this product for every specific experimental setup.

**Technical Support:** The protocols provided are for reference purposes. Unsure if this reagent suits your experiment?

**Need Industrial/Bulk Grade?** [Request Custom Synthesis Quote](#)

## BenchChem

Our mission is to be the trusted global source of essential and advanced chemicals, empowering scientists and researchers to drive progress in science and industry.

### Contact

Address: 3281 E Guasti Rd  
Ontario, CA 91761, United States  
Phone: (601) 213-4426  
Email: [info@benchchem.com](mailto:info@benchchem.com)

[Contact our Ph.D. Support Team for a compatibility check](#)