

Spectroscopic Analysis and Comparison of Fluorinated Pyridine Isomers

Author: BenchChem Technical Support Team. **Date:** April 2026

Compound of Interest

Compound Name: 2-fluoro-5-(fluoromethyl)pyridine

CAS No.: 1613417-64-3

Cat. No.: B6151442

[Get Quote](#)

Executive Summary

Fluorinated pyridines are critical pharmacophores in modern medicinal chemistry, widely utilized to modulate pKa, lipophilicity (

), and metabolic stability of drug candidates. The strategic placement of a fluorine atom on the pyridine ring—at the 2-, 3-, or 4-position—drastically alters the molecule's electronic landscape, reactivity, and spectroscopic signature.

This guide provides a technical comparison of 2-fluoropyridine, 3-fluoropyridine, and 4-fluoropyridine. It is designed for analytical chemists and synthetic researchers requiring precise data on spectroscopic differentiation (NMR, MS, IR) and physicochemical performance.

Part 1: Chemical Profile & Physicochemical Comparison[1]

The three isomers exhibit distinct physical properties driven by the inductive (

) and mesomeric (

) interplay between the fluorine atom and the nitrogen heterocycle.

Comparative Data Table

Property	2-Fluoropyridine	3-Fluoropyridine	4-Fluoropyridine
CAS Number	372-48-5	372-47-4	694-52-0
Structure	Ortho-substituted	Meta-substituted	Para-substituted
Boiling Point	126 °C	107–108 °C	104–105 °C
Basicity ()	-0.44 (Very Weak Base)	2.97 (Weak Base)	~4.15 (Predicted)*
Stability	Stable liquid	Stable liquid	Unstable (Polymerizes/Hydrolyzes); often stored as HCl salt
Dipole Moment	High (Vectors additive)	Moderate	Low (Vectors opposing)
Reactivity	High susceptibility	Lithiation/Benzyne chemistry	High susceptibility

> Note on 4-Fluoropyridine: The free base is thermally unstable and prone to self-polymerization or hydrolysis to 4-pyridone. Analytical samples should be generated in situ from the hydrochloride salt or handled at low temperatures.

Part 2: Spectroscopic Analysis

Nuclear Magnetic Resonance (NMR) Spectroscopy

NMR is the definitive tool for distinguishing these isomers. The electronegativity of fluorine (

) and the pyridine nitrogen (

) creates unique shielding/deshielding patterns.

NMR Signatures

Fluorine chemical shifts are highly sensitive to the electron density of the ring position relative to the nitrogen.

- Reference:

(

0.0 ppm).^[1]^[2]^[3]

- Trend: The 2-position is most deshielded due to the direct inductive effect of the adjacent nitrogen.

Isomer	Shift (ppm)	Multiplicity (-coupled)	Coupling Constants ()
2-Fluoropyridine	-71.0	dddd	0-2 Hz (small)
3-Fluoropyridine	-123.0	dddd	8-10 Hz
4-Fluoropyridine	-94.0	tt (triplet of triplets)	6-8 Hz

and

NMR Trends

- Coupling: Large one-bond couplings () are characteristic.
 - for 2-F.
 - for 3-F and 4-F.
- Deshielding: Protons ortho to the fluorine are shifted downfield. In 2-fluoropyridine, the H3 proton appears as a doublet of doublets with a large

coupling.

Mass Spectrometry (MS) Fragmentation

Under Electron Ionization (EI, 70 eV), the isomers show a molecular ion

at m/z 97. However, their fragmentation pathways differ based on the stability of the intermediates.

- Common Pathway: Loss of HCN (27 Da) to form

(m/z 70).
- Differentiation:
 - 2-Fluoropyridine: Shows a prominent loss of HF (20 Da) to form the

ion (m/z 77) due to the proximity of F to the Nitrogen lone pair, facilitating elimination.
 - 3-Fluoropyridine: Predominantly loses HCN first. The HF loss is less favorable compared to the 2-isomer.
 - 4-Fluoropyridine: Fragmentation is often dominated by the instability of the parent ion, leading to rapid degradation peaks if the inlet temperature is too high.

Vibrational Spectroscopy (IR)[1][5]

- C-F Stretch: Strong band in the 1150–1250 cm^{-1} region.
- Ring Breathing: Pyridine ring breathing modes ($\sim 990 \text{ cm}^{-1}$) are shifted and split by fluorine substitution.
- Differentiation: 2-fluoropyridine exhibits a distinct doublet in the C=N stretching region ($\sim 1590 \text{ cm}^{-1}$) due to Fermi resonance or coupling with ring vibrations, which is less pronounced in the symmetrical 4-isomer.

Part 3: Mechanism & Reactivity Visualization

The following diagram illustrates the electronic effects governing the reactivity and spectroscopic shifts of the isomers.

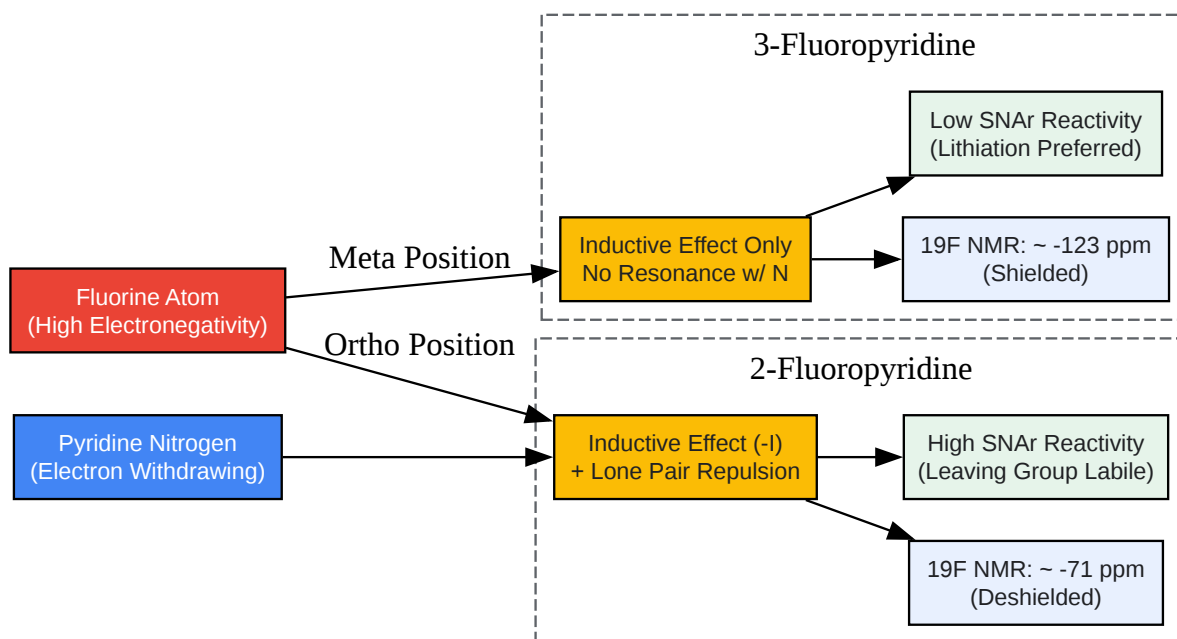

[Click to download full resolution via product page](#)

Caption: Electronic influence of nitrogen and fluorine placement on NMR chemical shifts and chemical reactivity.

Part 4: Experimental Protocol

Standardized GC-MS Analysis for Isomer Identification

Objective: To separate and identify fluoropyridine isomers in a mixed sample.

Reagents:

- Sample: 1 mg/mL in Dichloromethane (DCM).
- Internal Standard: Fluorobenzene (optional).

Instrument Parameters:

- Column: DB-5ms or equivalent (30 m x 0.25 mm, 0.25 μm film).

- Carrier Gas: Helium at 1.0 mL/min (constant flow).
- Inlet: Split 50:1, Temperature 250 °C. Note: For 4-fluoropyridine, lower inlet temp to 200 °C to prevent degradation.
- Oven Program:
 - Hold at 40 °C for 2 min.
 - Ramp 10 °C/min to 150 °C.
 - Ramp 25 °C/min to 280 °C.

Protocol Steps:

- Preparation: Dissolve 10 µL of the fluoropyridine isomer in 1.5 mL of HPLC-grade DCM.
- Injection: Inject 1.0 µL of the solution.
- Detection: Set MS scan range m/z 35–200.
- Analysis:
 - 2-Fluoropyridine: Elutes last (highest BP). Look for m/z 77 fragment (loss of HF).
 - 3-Fluoropyridine: Elutes mid-range. Look for dominant HCN loss.
 - 4-Fluoropyridine: Elutes first (lowest BP). Check peak shape; tailing indicates degradation.

References

- PubChem. (n.d.).^[4] 2-Fluoropyridine Compound Summary. National Library of Medicine. Retrieved from [\[Link\]](#)
- PubChem. (n.d.).^[4] 3-Fluoropyridine Compound Summary. National Library of Medicine. Retrieved from [\[Link\]](#)
- Dolbier, W. R. (2009). Guide to Fluorine NMR for Organic Chemists. Wiley. (General reference for ¹⁹F shift trends).

- Reich, H. J. (2023). Bordwell pKa Table (Acidity in DMSO). University of Wisconsin-Madison. (Reference for heterocyclic basicity trends).

Need Custom Synthesis?

BenchChem offers custom synthesis for rare earth carbides and specific isotopic labeling.

Email: info@benchchem.com or [Request Quote Online](#).

Sources

- [1. colorado.edu \[colorado.edu\]](https://colorado.edu)
- [2. 19F \[nmr.chem.ucsb.edu\]](https://nmr.chem.ucsb.edu)
- [3. alfa-chemistry.com \[alfa-chemistry.com\]](https://alfa-chemistry.com)
- [4. 4-Fluoropyridine | C5H4FN | CID 136504 - PubChem \[pubchem.ncbi.nlm.nih.gov\]](https://pubchem.ncbi.nlm.nih.gov/compound/4-Fluoropyridine)
- To cite this document: BenchChem. [Spectroscopic Analysis and Comparison of Fluorinated Pyridine Isomers]. BenchChem, [2026]. [Online PDF]. Available at: [\[https://www.benchchem.com/product/b6151442/docs#spectroscopic-analysis-and-comparison-of-fluorinated-pyridine-isomers\]](https://www.benchchem.com/product/b6151442/docs#spectroscopic-analysis-and-comparison-of-fluorinated-pyridine-isomers)

Disclaimer & Data Validity:

The information provided in this document is for Research Use Only (RUO) and is strictly not intended for diagnostic or therapeutic procedures. While BenchChem strives to provide accurate protocols, we make no warranties, express or implied, regarding the fitness of this product for every specific experimental setup.

Technical Support: The protocols provided are for reference purposes. Unsure if this reagent suits your experiment?

Need Industrial/Bulk Grade? [Request Custom Synthesis Quote](#)

BenchChem

Our mission is to be the trusted global source of essential and advanced chemicals, empowering scientists and researchers to drive progress in science and industry.

Contact

Address: 3281 E Guasti Rd

Ontario, CA 91761, United States

Phone: (601) 213-4426

Email: info@benchchem.com

[Contact our Ph.D. Support Team for a compatibility check](#)