

# Technical Guide: Scalable Synthesis and Application of 3-(Methoxymethoxy)azetidine

**Author:** BenchChem Technical Support Team. **Date:** April 2026

## Compound of Interest

Compound Name: 3-(methoxymethoxy)azetidine

CAS No.: 1697121-19-9

Cat. No.: B6146523

[Get Quote](#)

## Executive Summary

**3-(Methoxymethoxy)azetidine** (often isolated as the hydrochloride salt) is a high-value heterocyclic building block in medicinal chemistry.<sup>[1]</sup> It offers a protected hydroxyl group on a strained four-membered ring, allowing for the introduction of the azetidine motif—known for lowering lipophilicity (

) and improving metabolic stability—without exposing the reactive alcohol functionality during early-stage synthesis.

This guide outlines the technical synthesis of this core, prioritizing Process Safety and Scalability. We present two distinct routes:

- The "Gold Standard" Laboratory Route: Utilizing Methoxymethyl Chloride (MOM-Cl) for rapid, high-yield synthesis on a gram scale.<sup>[1]</sup>
- The "Green" Process Route: Utilizing Dimethoxymethane (Methylal) and solid acid catalysis to avoid the use of carcinogenic MOM-Cl, suitable for larger scale-up (100g+).

## Part 1: Retrosynthetic Analysis & Strategy

To access the target **3-(methoxymethoxy)azetidine (1)**, we must address two main challenges: the high ring strain of the azetidine (~26 kcal/mol) which makes the ring susceptible to opening under harsh nucleophilic conditions, and the potential toxicity of reagents used to install the methoxymethyl (MOM) ether.

The most logical disconnection is the removal of the nitrogen protecting group (PG), followed by the O-alkylation of the secondary alcohol.

### Strategic Disconnection (Graphviz Diagram)

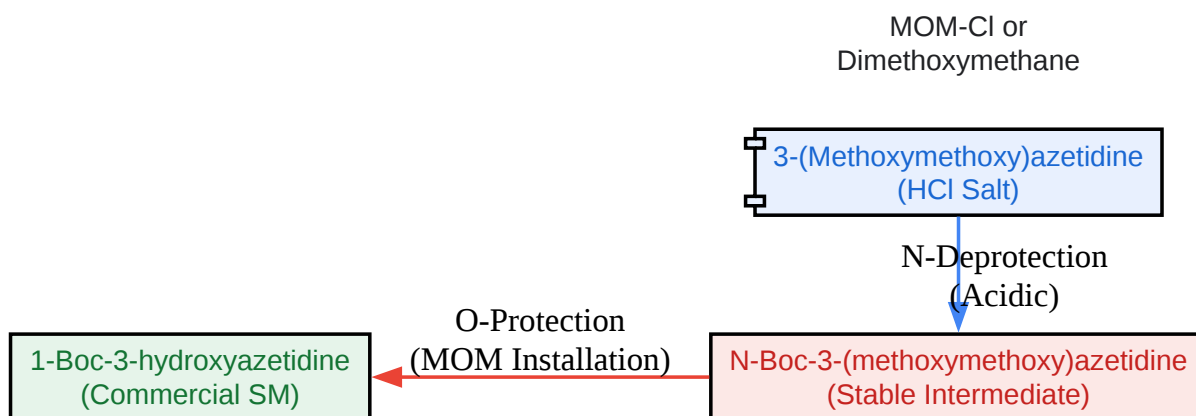

[Click to download full resolution via product page](#)

Figure 1: Retrosynthetic strategy focusing on the functionalization of the commercially available 1-Boc-3-hydroxyazetidine.

## Part 2: Experimental Protocols

### Route A: The "Gold Standard" Laboratory Synthesis

Best for: Small scale (1g – 10g), rapid throughput. Critical Hazard: Requires handling MOM-Cl (OSHA Carcinogen).[1]

#### Step 1: O-Protection of 1-Boc-3-hydroxyazetidine

This step utilizes Hunig's base (DIPEA) to scavenge HCl generated during the substitution.[1]

The reaction is run in DCM at

to control exothermicity.[1]

Reagents & Stoichiometry:

Reagent	Equiv.	Role
1-Boc-3-hydroxyazetidine	1.0	Substrate
MOM-Cl	1.5	Electrophile (Carcinogen)
DIPEA	2.0	Base / Proton Scavenger

| DCM (Anhydrous) | 0.2 M | Solvent |[1]

Protocol:

- Setup: Flame-dry a round-bottom flask and purge with  
. Add 1-Boc-3-hydroxyazetidine (1.0 equiv) and anhydrous DCM.
- Base Addition: Add DIPEA (2.0 equiv) and cool the solution to  
using an ice bath.
- Alkylation: In a fume hood, add MOM-Cl (1.5 equiv) dropwise via syringe over 15 minutes.[1]
  - Note: The solution may turn slightly cloudy due to amine-HCl salt formation.[1]
- Reaction: Allow to warm to Room Temperature (RT) and stir for 12–16 hours. Monitor by TLC (30% EtOAc/Hexanes; Stain: KMnO<sub>4</sub>).[1] Product  
.[1]
- Workup: Quench with saturated [ngcontent-ng-c2977031039="" \\_ngghost-ng-c1310870263="" class="inline ng-star-inserted">](#)

- Extract with DCM ( )<sup>[1]</sup><sup>[2]</sup> Wash combined organics with brine, dry over , and concentrate.<sup>[2]</sup>
- Purification: Flash column chromatography (0 30% EtOAc in Hexanes) yields 1-Boc-**3-(methoxymethoxy)azetidine** as a colorless oil.<sup>[1]</sup>

## Step 2: N-Deprotection to Hydrochloride Salt

Removal of the Boc group must be done under anhydrous acidic conditions to prevent hydrolysis of the MOM acetal, although MOM is generally stable to basic and mild acidic conditions.

Protocol:

- Dissolve the intermediate from Step 1 in or -Dioxane.<sup>[1]</sup>
- Cool to and add (5.0 equiv).
- Stir at RT for 4 hours. A white precipitate should form.<sup>[1]</sup>
- Isolation: Filter the solid under (hygroscopic). Wash with cold .<sup>[1]</sup>
- Product:**3-(methoxymethoxy)azetidine** hydrochloride (White solid).<sup>[1]</sup>

## Route B: The "Green" Process Synthesis (MOM-Cl Free)

Best for: Scale-up (>50g), safety-critical environments.[1] Mechanism: Acid-catalyzed acetal exchange using Dimethoxymethane (Methylal).[1]

This route avoids bis(chloromethyl)ether (a byproduct of MOM-Cl synthesis).[1] We utilize Phosphorus Pentoxide (

) or a solid acid catalyst to generate the reactive oxonium species in situ.[1]

Reagents & Stoichiometry:

Reagent	Equiv.	Role
1-Boc-3-hydroxyazetidine	1.0	Substrate
Dimethoxymethane	10-20	Reagent & Solvent

|

| 0.5-1.0 | Dehydrating Agent / Catalyst [[1]

Protocol:

- Slurry Formation: In a reactor, suspend 1-Boc-3-hydroxyazetidine in Dimethoxymethane (Methylal).
- Catalyst Addition: Add portion-wise at RT.[1] Caution: Exothermic.[1]
- Reaction: Stir vigorously at RT for 24 hours. The will eventually form a gummy phosphoric acid residue.[1]
- Quench: Decant the liquid into a saturated solution (slowly, gas evolution).
- Extraction: Extract the aqueous layer with EtOAc.[1]

- Purification: Distillation or filtration through a silica plug is usually sufficient due to the cleanliness of the acetal exchange.[\[1\]](#)

## Part 3: Analytical Characterization[\[1\]](#)

To validate the synthesis, the following analytical data should be obtained.

### 3-(Methoxymethoxy)azetidine Hydrochloride

- Physical State: White, hygroscopic solid.[\[1\]](#)

- (

- ):

- (s, 2H,

- )

- (m, 1H,

- )

- (dd, 2H,

- )

- (dd, 2H,

- )

- (s, 3H,

- )

- : Distinct signals for the acetal carbon (

- ) and the methoxy group (

- ).

- Mass Spectrometry (ESI): Calculated for

; Found:

[1]

## Workflow Visualization

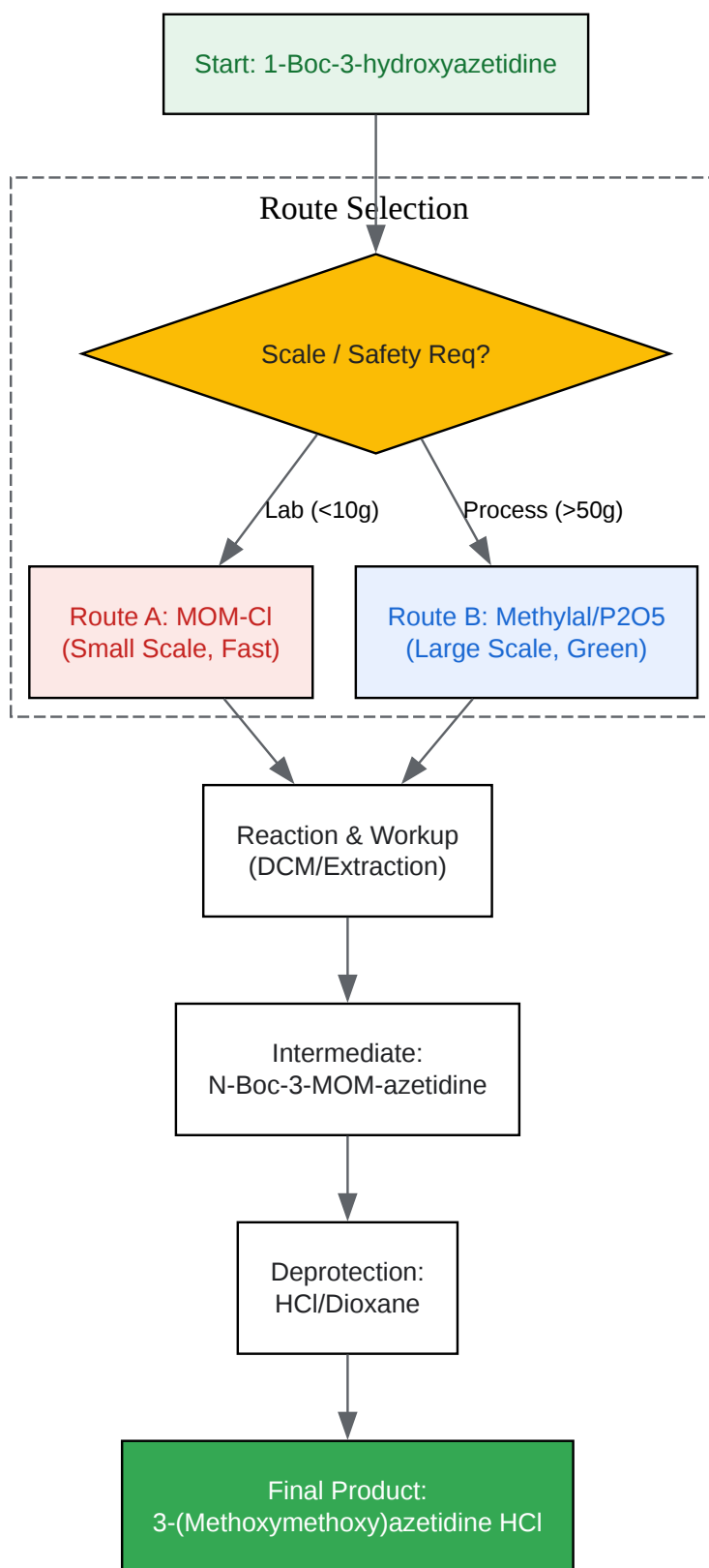

[Click to download full resolution via product page](#)

Figure 2: Decision tree for selecting the synthesis route based on scale and safety constraints.

## Part 4: Safety & Handling (E-E-A-T)

### MOM-Cl Toxicity

Chloromethyl methyl ether (MOM-Cl) is a potent alkylating agent and a regulated carcinogen (OSHA 1910.1006).[1]

- Engineering Controls: Must be handled in a certified fume hood with a sash face velocity >100 fpm.
- Destruction: Quench excess MOM-Cl with aqueous ammonia or concentrated ammonium hydroxide to form the safer hexamethylenetetramine or simple amines before disposal.[1]

### Azetidine Stability

The free base of **3-(methoxymethoxy)azetidine** is a strained secondary amine.[1]

- Storage: Store as the Hydrochloride salt at  
  
. The free base is prone to polymerization and ring-opening if left neat at room temperature.  
[1]
- Handling: When using the salt in subsequent reactions (e.g., amide coupling), liberate the free base in situ using a tertiary amine (TEA or DIPEA) rather than isolating it.

### References

- Wuts, P. G. M., & Greene, T. W. (2006).[1] Greene's Protective Groups in Organic Synthesis. Wiley-Interscience.[1] (Standard reference for MOM protection conditions and stability).
- BenchChem. (2025).[1][3] Technical Support Center: Methoxymethyl (MOM) Ether Protecting Group.[1][2] (Detailed protocols for MOM-Cl and Dimethoxymethane methods).
- Sigma-Aldrich. (2025).[1] 1-Boc-3-hydroxyazetidine Product Information. (Physical properties and safety data for the starting material).
- Fujioka, H., et al. (2009).[1][4] One-Pot Synthesis of MOM Ethers from Acetals. Organic Letters, 11(22), 5138–5141. (Primary literature for "Green" acetal exchange methodology).

- National Institutes of Health (NIH). (2023).[1] Synthesis of New Azetidine Amino Acid Derivatives. (Validation of N-Boc-3-hydroxyazetidine usage in synthesis).

### Need Custom Synthesis?

BenchChem offers custom synthesis for rare earth carbides and specific isotopic labeling.

Email: [info@benchchem.com](mailto:info@benchchem.com) or [Request Quote Online](#).

## Sources

- 1. 1-Boc-3-hydroxyazetidine 97 141699-55-0 [[sigmaaldrich.com](https://www.sigmaaldrich.com)]
- 2. [pdf.benchchem.com](https://pdf.benchchem.com) [[pdf.benchchem.com](https://pdf.benchchem.com)]
- 3. [pdf.benchchem.com](https://pdf.benchchem.com) [[pdf.benchchem.com](https://pdf.benchchem.com)]
- 4. [organic-chemistry.org](https://www.organic-chemistry.org) [[organic-chemistry.org](https://www.organic-chemistry.org)]
- To cite this document: BenchChem. [Technical Guide: Scalable Synthesis and Application of 3-(Methoxymethoxy)azetidine]. BenchChem, [2026]. [Online PDF]. Available at: [<https://www.benchchem.com/product/b6146523/docs#technical-guide-scalable-synthesis-and-application-of-3-methoxymethoxy-azetidine>]

---

### Disclaimer & Data Validity:

The information provided in this document is for Research Use Only (RUO) and is strictly not intended for diagnostic or therapeutic procedures. While BenchChem strives to provide accurate protocols, we make no warranties, express or implied, regarding the fitness of this product for every specific experimental setup.

**Technical Support:** The protocols provided are for reference purposes. Unsure if this reagent suits your experiment?

**Need Industrial/Bulk Grade?** [Request Custom Synthesis Quote](#)

# BenchChem

Our mission is to be the trusted global source of essential and advanced chemicals, empowering scientists and researchers to drive progress in science and industry.

## Contact

Address: 3281 E Guasti Rd

Ontario, CA 91761, United States

Phone: (601) 213-4426

Email: [info@benchchem.com](mailto:info@benchchem.com)

[Contact our Ph.D. Support Team for a compatibility check](#)