

Technical Support Center: S-Trityl Deprotection of Homocysteine

Author: BenchChem Technical Support Team. **Date:** May 2026

Compound of Interest

Compound Name: *Boc-S-trityl-L-homocysteine*

CAS No.: 201419-16-1

Cat. No.: B613626

[Get Quote](#)

This guide provides detailed troubleshooting advice, frequently asked questions (FAQs), and experimental protocols for the successful S-trityl deprotection of homocysteine residues in peptides and other molecules.

Frequently Asked Questions (FAQs)

Q1: What is the primary role of a scavenger in S-trityl deprotection?

Scavengers are essential for ensuring the complete and irreversible removal of the trityl protecting group. During acid-catalyzed cleavage (typically with Trifluoroacetic Acid - TFA), a stable trityl carbocation is generated. This cation is highly reactive and can re-attach to the newly freed nucleophilic thiol group of homocysteine, leading to an incomplete reaction.^[1] Scavengers are added to the cleavage cocktail to "trap" or "quench" these trityl cations as they form, thus preventing this re-attachment and driving the reaction to completion.^[1]

Q2: Why is my S-trityl deprotection incomplete? I see the protected starting material in my analysis.

Incomplete deprotection is a common issue and is almost always due to the reversible nature of the acid-mediated cleavage.[1] Without a sufficient concentration of an effective scavenger, the liberated trityl cation will simply re-protect the homocysteine thiol.[1] The solution is to use an adequate amount of a potent scavenger like Triisopropylsilane (TIS).

Q3: What are the most effective scavengers for S-trityl deprotection?

Silane-based scavengers are highly effective because they irreversibly reduce the trityl cation to the inert hydrocarbon triphenylmethane.[1][2]

- Triisopropylsilane (TIS): Considered one of the most effective and widely used scavengers for this purpose.[1][3]
- Triethylsilane (TES): Also very effective and functions similarly to TIS.[4]
- 1,2-Ethanedithiol (EDT): A good scavenger for trityl cations that also helps prevent the oxidation of the free thiol to form disulfide bonds.[5]

Q4: I'm observing significant disulfide bond formation (dimerization) in my product. How can I prevent this?

The free thiol of homocysteine is susceptible to oxidation, which leads to the formation of disulfide-linked dimers or oligomers.[1] This can be minimized by:

- Adding a reducing agent to the cleavage cocktail, such as 1,2-Ethanedithiol (EDT) or Dithiothreitol (DTT).[1][6]
- Working under an inert atmosphere (e.g., nitrogen or argon) where possible.
- Keeping the work-up and purification steps as brief as possible.

Q5: Can scavengers cause side reactions with other amino acids?

Yes, scavengers must be chosen carefully based on the peptide sequence. For example, trialkylsilanes (TIS, TES) in TFA can reduce the indole ring of tryptophan.[4][7] For peptides containing sensitive residues like Cys, Met, or Trp, a more complex and protective cocktail like Reagent K is often recommended.[1][5]

Troubleshooting Guide

This guide addresses common problems encountered during the S-trityl deprotection of homocysteine.

Problem	Potential Cause	Recommended Solution
Incomplete Deprotection (Significant starting material remains)	1. Insufficient or no scavenger used.[1] 2. Reaction time is too short.	1. Use an effective scavenger like TIS or TES at 2.5-5% (v/v) in the cleavage cocktail.[1][5] 2. Extend the reaction time to 2-4 hours at room temperature. [1]
Disulfide Formation (Presence of dimers/oligomers)	The free homocysteine thiol is oxidizing.[1]	Add a reducing agent like 1,2-ethanedithiol (EDT) (2.5% v/v) to the cleavage cocktail.[1][5]
Unexpected Side Products (Unidentified peaks in HPLC/LC-MS)	Alkylation of sensitive residues (e.g., Trp, Met) by carbocations from other protecting groups (e.g., t-butyl).[5]	Use a scavenger cocktail designed for sensitive residues, such as Reagent K. [1][6] Ensure appropriate protecting groups were used during synthesis, like Boc for Trp.[5]
Low Yield of Precipitated Peptide	The deprotected peptide has some solubility in the precipitation solvent (e.g., cold diethyl ether).	Ensure the ether is ice-cold. Minimize the volume of TFA before precipitation. Try a different precipitation solvent if issues persist.

Cleavage Cocktails & Scavengers

The choice of cleavage cocktail is critical for successful deprotection and depends on the other amino acid residues present in your molecule.

Cocktail Name	Composition (v/v/v)	Primary Use & Features
Standard Cocktail	95% TFA / 2.5% TIS / 2.5% H ₂ O	A general-purpose and highly effective cocktail for most sequences that do not contain highly sensitive residues like tryptophan or methionine.[1][5]
Reagent K	82.5% TFA / 5% Phenol / 5% H ₂ O / 5% Thioanisole / 2.5% EDT	Recommended for peptides containing multiple sensitive residues such as Cys, Met, or Trp, as it minimizes alkylation and oxidation side reactions.[1][5]
TFA / EDT	95% TFA / 2.5% H ₂ O / 2.5% EDT	A good choice when the primary concern is preventing disulfide formation and the sequence is not sensitive to other side reactions.

Experimental Protocols

Protocol 1: General S-Trityl Deprotection from a Resin-Bound Peptide

This protocol describes the standard procedure for cleaving a peptide from the resin while simultaneously deprotecting the S-trityl group on a homocysteine residue.

- **Resin Preparation:** Place the dry, peptide-bound resin in a suitable reaction vessel (e.g., a fritted syringe).
- **Reagent Preparation:** Prepare the chosen cleavage cocktail (see tables above) in a fume hood. For 100 mg of resin, you will typically need 2-3 mL of the cocktail.
- **Cleavage Reaction:** Add the cleavage cocktail to the resin. Ensure the resin is fully wetted. Gently agitate the mixture at room temperature for 2-4 hours.[1]

- **Peptide Collection:** After the incubation period, filter the solution containing the cleaved peptide away from the resin beads. Collect the filtrate.
- **Resin Wash:** Wash the resin beads with a small, fresh volume of TFA (0.5 mL) and combine the filtrate with the collection from the previous step.
- **TFA Removal:** Reduce the volume of the combined TFA filtrate by approximately 80-90% under a gentle stream of nitrogen or using a rotary evaporator. Caution: Do not evaporate to complete dryness.
- **Peptide Precipitation:** Add the concentrated peptide solution dropwise into a centrifuge tube containing ice-cold diethyl ether (typically 10-15 mL). A white precipitate should form.
- **Isolation and Wash:** Centrifuge the mixture to pellet the crude peptide. Carefully decant the ether. Wash the pellet with another portion of cold diethyl ether to remove residual scavengers and organic impurities, then centrifuge and decant again.
- **Drying:** Dry the final peptide pellet under a high vacuum to remove all traces of solvent. The peptide is now ready for purification (e.g., by HPLC).

Visualized Workflows and Mechanisms

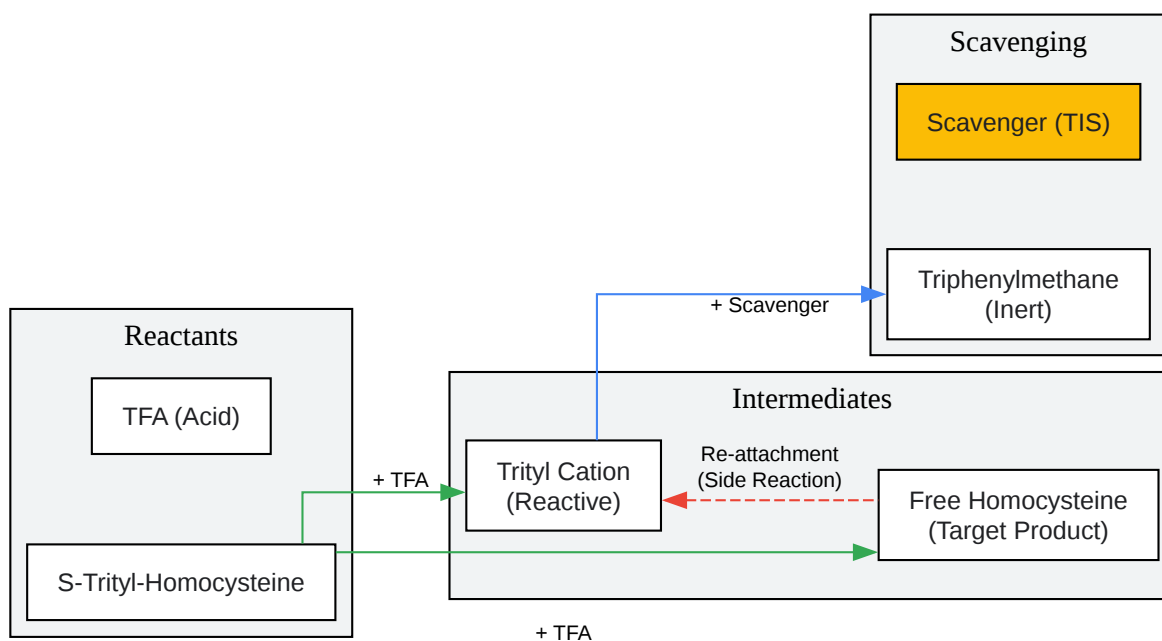

[Click to download full resolution via product page](#)

Caption: S-Tryl deprotection mechanism showing the role of a scavenger.

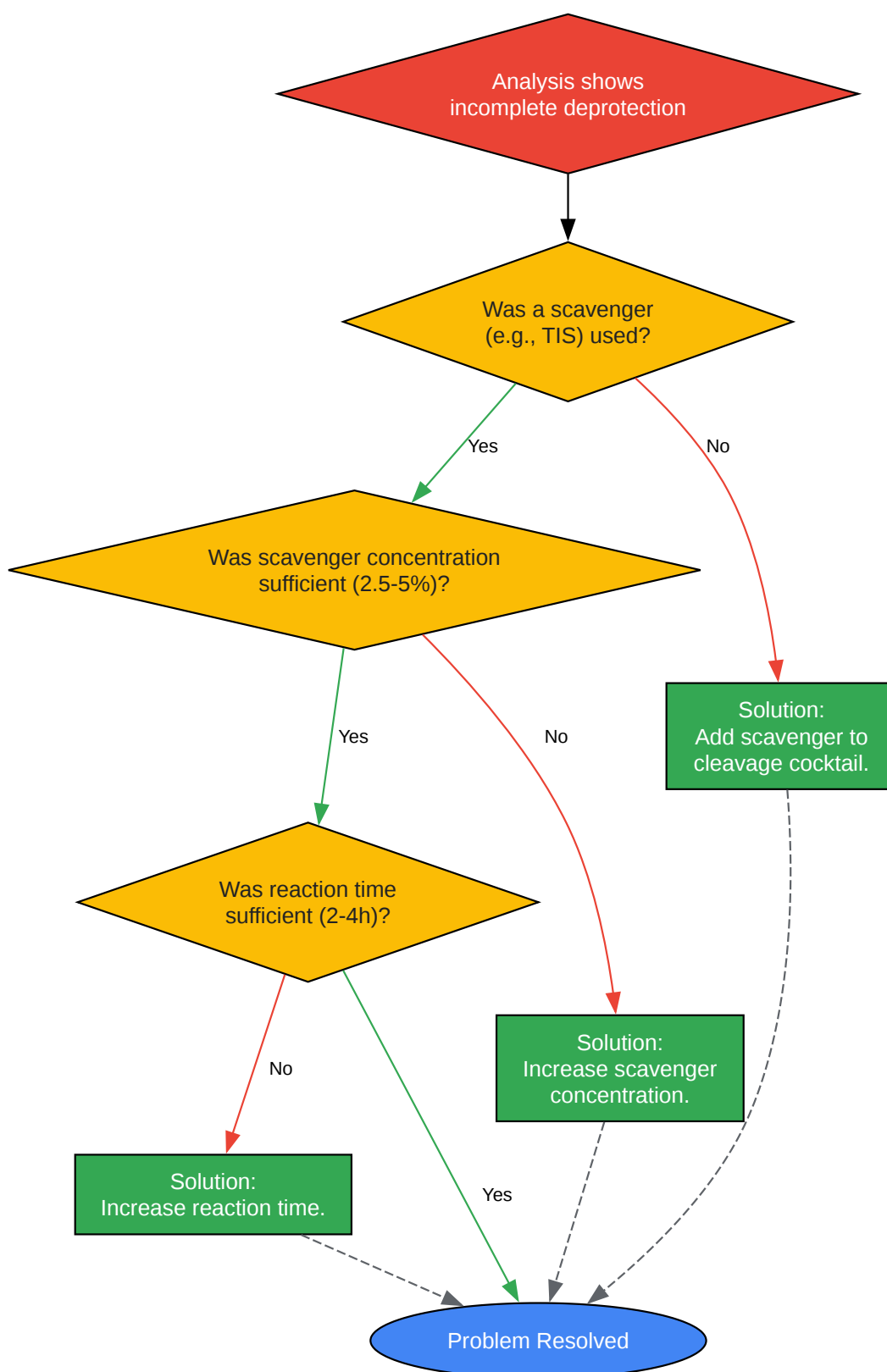

[Click to download full resolution via product page](#)

Caption: Troubleshooting workflow for incomplete S-Trityl deprotection.

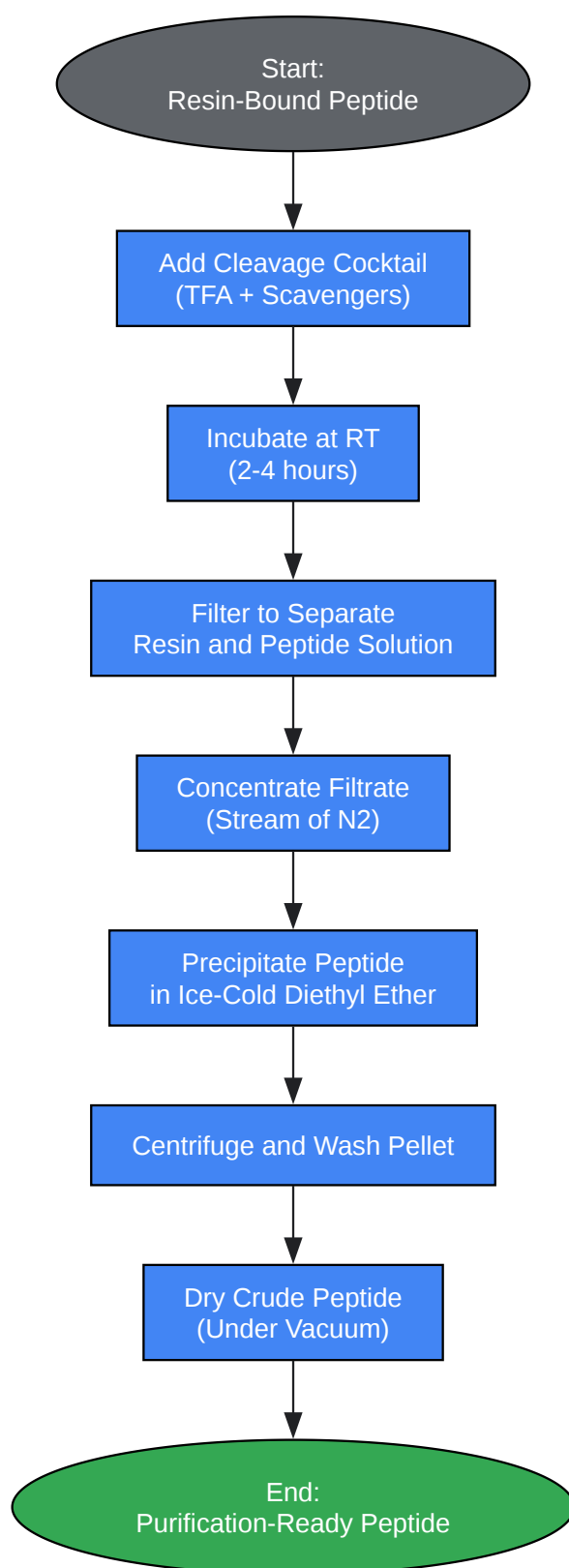

[Click to download full resolution via product page](#)

Caption: Standard experimental workflow for cleavage and deprotection.

Need Custom Synthesis?

BenchChem offers custom synthesis for rare earth carbides and specific isotopic labeling.

Email: info@benchchem.com or [Request Quote Online](#).

References

- [1. benchchem.com \[benchchem.com\]](https://www.benchchem.com)
- [2. bachem.com \[bachem.com\]](https://www.bachem.com)
- [3. Reduction of cysteine-S-protecting groups by triisopropylsilane - PMC \[pmc.ncbi.nlm.nih.gov\]](https://pubmed.ncbi.nlm.nih.gov/12345678/)
- [4. researchgate.net \[researchgate.net\]](https://www.researchgate.net)
- [5. Fmoc Resin Cleavage and Deprotection \[sigmaaldrich.com\]](https://www.sigmaaldrich.com)
- [6. benchchem.com \[benchchem.com\]](https://www.benchchem.com)
- [7. researchgate.net \[researchgate.net\]](https://www.researchgate.net)
- To cite this document: BenchChem. [Technical Support Center: S-Trityl Deprotection of Homocysteine]. BenchChem, [2026]. [Online PDF]. Available at: [\[https://www.benchchem.com/product/b613626/docs#technical-support-center-s-trityl-deprotection-of-homocysteine\]](https://www.benchchem.com/product/b613626/docs#technical-support-center-s-trityl-deprotection-of-homocysteine)

Disclaimer & Data Validity:

The information provided in this document is for Research Use Only (RUO) and is strictly not intended for diagnostic or therapeutic procedures. While BenchChem strives to provide accurate protocols, we make no warranties, express or implied, regarding the fitness of this product for every specific experimental setup.

Technical Support: The protocols provided are for reference purposes. Unsure if this reagent suits your experiment?

Need Industrial/Bulk Grade? [Request Custom Synthesis Quote](#)

BenchChem

Our mission is to be the trusted global source of essential and advanced chemicals, empowering scientists and researchers to drive progress in science and industry.

Contact

Address: 3281 E Guasti Rd

Ontario, CA 91761, United States

Phone: (601) 213-4426

Email: info@benchchem.com

[Contact our Ph.D. Support Team for a compatibility check](#)