

# Technical Guide: Mass Spectrometry of Peptides with S-Sulfonate Modification

**Author:** BenchChem Technical Support Team. **Date:** May 2026

## Compound of Interest

Compound Name: 163558-30-3

CAS No.: 163558-30-3

Cat. No.: B613541

[Get Quote](#)

## Executive Summary

S-sulfonation (S-sulfocysteine,

) is a reversible post-translational modification (PTM) critical in two primary contexts: protein refolding (sulfitolysis to resolve scrambled disulfide bonds in monoclonal antibodies) and oxidative stress biomarkers (irreversible oxidation of cysteine).

Unlike standard alkylation (e.g., carbamidomethylation, +57.02 Da), S-sulfonation (+79.96 Da) is chemically labile and highly acidic. This guide compares analytical strategies for characterizing S-sulfonated peptides, demonstrating why standard "bottom-up" proteomics workflows often fail and establishing Electron Transfer Dissociation (ETD) and High-Resolution MS as the requisite standards for accurate validation.

## Part 1: The Physicochemical Challenge

The analysis of S-sulfonated peptides presents three distinct challenges compared to standard alkylated peptides:

- **Lability:** The S-S bond connecting the sulfonate group to the cysteine thiol is fragile. Standard Collision-Induced Dissociation (CID) energy preferentially cleaves this bond before the peptide backbone, causing a "neutral loss" that obscures sequence information.
- **Isobaric Interference:** The mass shift of S-sulfonation ( ) is +79.9568 Da. This is nearly isobaric with Phosphorylation ( , +79.9663 Da). Low-resolution instruments cannot distinguish these modifications (Difference 0.01 Da).
- **Negative Charge:** The sulfonic acid group is strongly acidic ( ), introducing a negative charge that alters ionization efficiency in positive mode ESI.

## Table 1: Mass Shift Comparison

Modification	Formula Added	Monoisotopic Mass Shift (Da)	Stability (Reducing Conditions)	Stability (CID Fragmentation )
Carbamidomethylation		+57.0215	Stable	Stable
S-Sulfonation		+79.9568	Unstable (Reverts to thiol)	Unstable (Neutral Loss)
Phosphorylation		+79.9663	Stable	Labile (Neutral Loss)

## Part 2: Comparative Workflow Analysis

This section evaluates the three primary fragmentation methodologies for characterizing S-sulfonated peptides.

### Method A: Beam-Type CID / HCD (Screening)

Best for: Detecting the presence of the modification.

In Higher-energy Collisional Dissociation (HCD), the vibrational energy distributes rapidly. The weakest bond—the S-S bond of the sulfonate—breaks first.

- Outcome: The spectrum is dominated by a single intense peak corresponding to the precursor mass minus 80 Da ( ).
- Pros: High sensitivity; the "neutral loss" pattern acts as a diagnostic signature.
- Cons: "Catastrophic" loss of the modification means the backbone b- and y-ions are often too weak to sequence the peptide or localize the site if multiple cysteines are present.

## Method B: Electron Transfer Dissociation (ETD) (Characterization)

Best for: Site localization and Sequence Validation.

ETD uses radical ion chemistry to cleave the

bond of the peptide backbone. This process is non-ergodic, meaning bond cleavage occurs faster than energy randomization.

- Outcome: The labile S-sulfonate side chain remains intact. The spectrum shows a rich series of c- and z-ions carrying the +80 Da modification.
- Pros: Unambiguous site localization; preserves the PTM.
- Cons: Lower sensitivity for doubly charged precursors; requires specific instrumentation (e.g., Orbitrap Fusion/Eclipse or similar).

## Method C: Negative Ion Mode (Validation)

Best for: Confirmation of Sulfonate vs. Phosphate.

Because the sulfonate group is negatively charged, analyzing the peptide in negative ion mode can improve ionization efficiency for acidic peptides.

- Outcome: Generation of specific diagnostic ions, such as

(  
80) or  
(  
81).

- Pros: High specificity.
- Cons: Most proteomics software pipelines are not optimized for negative mode sequencing.

## Visualization: Fragmentation Pathways

The following diagram illustrates the divergent pathways of HCD vs. ETD for an S-sulfonated precursor.

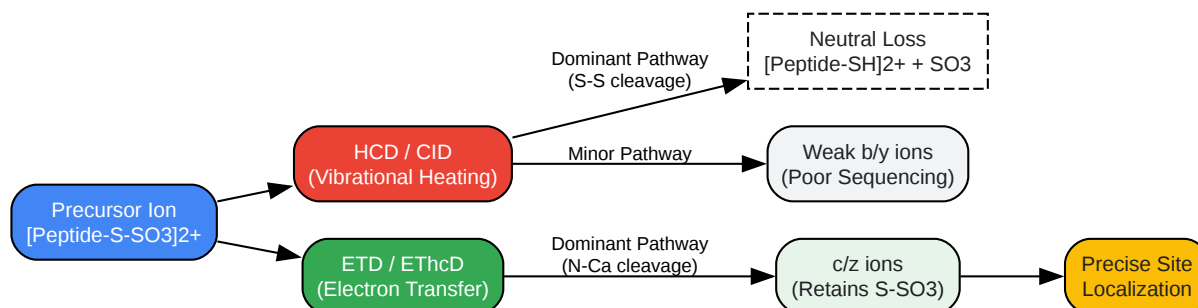

[Click to download full resolution via product page](#)

Caption: Comparative fragmentation pathways. HCD results in neutral loss of the sulfonate group, while ETD preserves the modification for sequence mapping.

## Part 3: Experimental Protocol (The Non-Reducing Workflow)

To successfully analyze S-sulfonated peptides, one must deviate from the standard proteomics workflow. Reducing agents (DTT, TCEP,

-ME) must be strictly avoided after the sulfitolysis step, as they will strip the sulfonate group and revert the cysteine to a free thiol.

## Reagents

- Sulfitolysis Buffer: 0.1M Na<sub>2</sub>SO<sub>3</sub> (Sodium Sulfite) + 10mM Na<sub>2</sub>S<sub>4</sub>O<sub>6</sub> (Sodium Tetrathionate) in 8M Urea, pH 8.0.
- Digestion Buffer: 50mM Ammonium Bicarbonate (pH 7.8).
- Protease: Trypsin (Sequencing Grade) or Glu-C.

## Step-by-Step Methodology

- Sulfitolysis (Generation):
  - Dissolve protein in Sulfitolysis Buffer.
  - Incubate at room temperature for 3-4 hours. Mechanism: Sulfite cleaves disulfides; Tetrathionate acts as an oxidant to drive the equilibrium toward S-sulfonate formation.
  - CRITICAL: Do not add Iodoacetamide (IAM). The cysteine is already "capped" by the sulfonate.
- Buffer Exchange (Cleanup):
  - The high salt (sulfite) content will suppress ionization. Use molecular weight cutoff (MWCO) spin filters or desalting columns (e.g., Zeba) to exchange into the Digestion Buffer.
  - Note: Maintain pH < 8.5. S-sulfonates are stable in mild acid/base but can hydrolyze at extreme pH.
- Digestion (Non-Reducing):
  - Add Trypsin (1:50 enzyme-to-protein ratio).
  - Incubate overnight at 37°C.

- Stop Reaction: Acidify with Formic Acid to pH 2–3. S-sulfonates are highly stable in acidic conditions (unlike standard disulfides which can scramble, sulfonates are robust in acid).
- LC-MS Acquisition:
  - Column: C18 Reverse Phase.
  - Mobile Phase: Water/Acetonitrile with 0.1% Formic Acid.
  - MS Method:
    - Survey Scan: 120k Resolution (Orbitrap) to distinguish from Phospho.
    - Fragmentation: Decision Tree.
      - If charge state  
3: Trigger ETD.
      - If charge state = 2: Trigger EThcD (hybrid) or HCD with low collision energy.

## Workflow Diagram

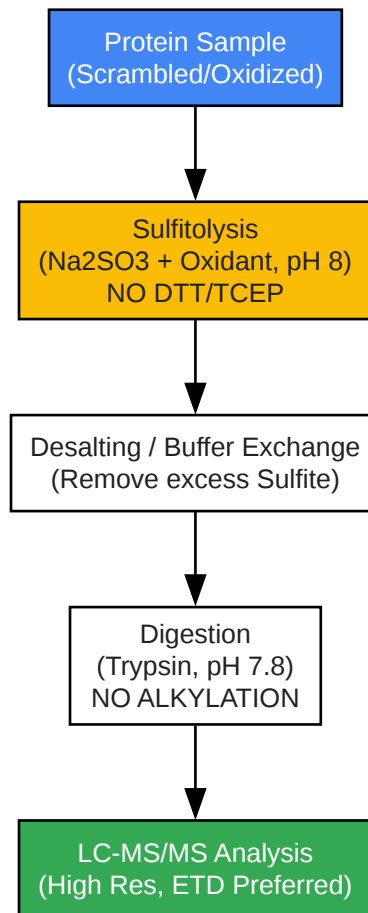

[Click to download full resolution via product page](#)

Caption: The "Non-Reducing" workflow ensures the S-sulfonate modification remains intact prior to injection.

## Part 4: Data Interpretation & Quality Control

### Distinguishing S-Sulfonate from Phosphorylation

As noted, the mass difference is ~10 mDa.

- Requirement: An MS1 resolution of >60,000 at 400 m/z is required to baseline separate these peaks.
- Check: If you see a "mixed" spectrum or broad peak, check the mass error.
  - : Mass defect is lower (+79.9568).

- : Mass defect is higher (+79.9663).

## The "Neutral Loss" Artifact

If you are limited to HCD/CID instruments (e.g., Q-TOF or standard Orbitrap), you must search for the neutral loss.

- Search Parameter: Variable Modification on Cys: +79.9568 Da.
- Validation: Look for the "diagnostic doublet" in the MS/MS spectrum:
  - The Precursor Ion.
  - The Precursor Ion minus 80 Da (often the base peak). If this doublet is absent, the identification is likely a false positive.

## False Discovery Rate (FDR)

S-sulfonation increases the hydrophilicity of the peptide, causing it to elute earlier than its unmodified or alkylated counterpart on C18 columns. Use this retention time shift as a secondary validation metric.

## References

- Kishikawa, M., et al. (2000).[1] "Detection by mass spectrometry of highly increased amount of S-sulfonated transthyretin in serum from a patient with molybdenum cofactor deficiency." Pediatric Research.
- Chowdhury, S. M., et al. (2011). "Collision Induced Dissociation Versus Electron Transfer Dissociation for the Analysis of Protein Ubiquitination and Sulfonation." Journal of Proteome Research. (Contextualizes ETD superiority for labile mods).
- Thermo Fisher Scientific. "Protein Sample Preparation for Mass Spectrometry." (General guidelines on lysis and buffer compatibility).
- NIST. "Mass Spectrometry Data Center." (Reference for atomic masses and isotopic distributions).

### Need Custom Synthesis?

BenchChem offers custom synthesis for rare earth carbides and specific isotopic labeling.

Email: [info@benchchem.com](mailto:info@benchchem.com) or [Request Quote Online](#).

## Sources

- [1. Detection by mass spectrometry of highly increased amount of S-sulfonated transthyretin in serum from a patient with molybdenum cofactor deficiency - PubMed](#) [pubmed.ncbi.nlm.nih.gov]
- To cite this document: BenchChem. [Technical Guide: Mass Spectrometry of Peptides with S-Sulfonate Modification]. BenchChem, [2026]. [Online PDF]. Available at: [https://www.benchchem.com/product/b613541/docs#technical-guide-mass-spectrometry-of-peptides-with-s-sulfonate-modification]

### Disclaimer & Data Validity:

The information provided in this document is for Research Use Only (RUO) and is strictly not intended for diagnostic or therapeutic procedures. While BenchChem strives to provide accurate protocols, we make no warranties, express or implied, regarding the fitness of this product for every specific experimental setup.

**Technical Support:** The protocols provided are for reference purposes. Unsure if this reagent suits your experiment?

**Need Industrial/Bulk Grade?** [Request Custom Synthesis Quote](#)

## BenchChem

Our mission is to be the trusted global source of essential and advanced chemicals, empowering scientists and researchers to drive progress in science and industry.

### Contact

Address: 3281 E Guasti Rd  
Ontario, CA 91761, United States  
Phone: (601) 213-4426  
Email: [info@benchchem.com](mailto:info@benchchem.com)

Contact our Ph.D. Support Team for a compatibility check