

# How to avoid racemization during fluorescent amino acid coupling

**Author:** BenchChem Technical Support Team. **Date:** May 2026

## Compound of Interest

Compound Name: *Fmoc-Lys(Dansyl)-OH*

CAS No.: 118584-90-0

Cat. No.: B613415

[Get Quote](#)

## Technical Support Center: Fluorescent Amino Acid Coupling

A Senior Application Scientist's Guide to Preventing Racemization

Welcome to the Technical Support Center. This guide is designed for researchers, scientists, and drug development professionals who are incorporating fluorescent amino acids into their peptide synthesis workflows. Fluorescent labeling is a powerful tool, but the unique steric and electronic properties of these amino acids can increase the risk of racemization—a critical loss of stereochemical integrity that can compromise the biological activity and purity of your final peptide.

This document provides in-depth troubleshooting advice, preventative strategies, and validated protocols to help you maintain chiral purity during this crucial coupling step.

## Understanding the Core Problem: Racemization

Before troubleshooting, it's essential to understand the primary mechanism of racemization during peptide synthesis. For N $\alpha$ -protected amino acids (like Fmoc or Boc derivatives), the main pathway is through the formation of a 5(4H)-oxazolone intermediate.[1][2]

Here's the breakdown:

- Activation: The carboxylic acid of the fluorescent amino acid is activated by a coupling reagent.
- Oxazolone Formation: The activated carboxyl group is susceptible to intramolecular attack by the protecting group's carbonyl oxygen, forming a planar oxazolone ring.
- Loss of Chirality: The  $\alpha$ -proton on this planar intermediate is now acidic and can be easily removed by a base. Re-protonation can occur from either side of the planar ring, resulting in a mixture of L- and D-isomers (a racemic mixture).[1][2][3]

A secondary, less common mechanism involves the direct abstraction of the  $\alpha$ -proton by a strong base, which is why base selection is critical.[2][3] Fluorescent amino acids, often bulky and sterically hindered, can slow down the desired coupling reaction, giving the oxazolone intermediate more time to form and racemize.[4][5]

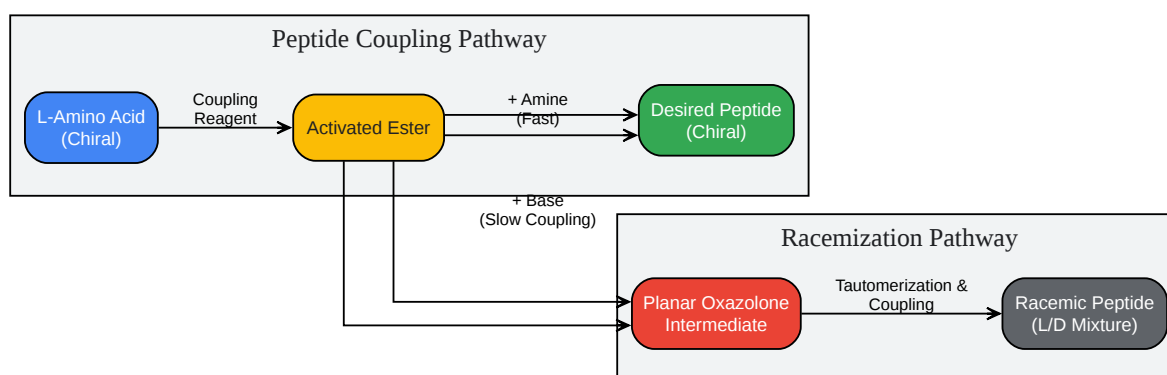

[Click to download full resolution via product page](#)

Caption: Primary racemization pathway via the oxazolone intermediate.

## Troubleshooting Guide (Q&A Format)

This section addresses specific issues you might encounter.

Q1: My final peptide has a significant diastereomeric impurity detected by HPLC. Could this be racemization from my fluorescent amino acid coupling step?

A1: Yes, this is a classic sign of racemization. The bulky nature of many fluorescent probes can hinder the coupling reaction, increasing the lifetime of the activated amino acid.<sup>[4]</sup> This extended lifetime provides a larger window for oxazolone formation and subsequent racemization.

Troubleshooting Steps:

- **Re-evaluate Your Coupling Reagent:** Standard carbodiimide reagents like Dicyclohexylcarbodiimide (DCC) or Diisopropylcarbodiimide (DIC) are often insufficient for sterically hindered couplings and can lead to high levels of racemization.<sup>[5][6]</sup>
  - **Solution:** Switch to a more potent aminium/uronium or phosphonium salt reagent. Reagents like HATU, HBTU, and PyBOP are generally more effective.<sup>[5][6][7]</sup> For extremely difficult couplings, COMU has shown superior performance in maintaining chiral purity.<sup>[6][8]</sup>
- **Check Your Additive:** If you are using a carbodiimide, an additive is essential to suppress racemization.<sup>[9][10]</sup>
  - **Solution:** Additives like 1-Hydroxybenzotriazole (HOBt) or Ethyl 2-cyano-2-(hydroxyimino)acetate (OxymaPure) react with the activated intermediate to form a more stable active ester, which is less prone to racemization.<sup>[1][8][11]</sup> OxymaPure and its derivatives are generally considered superior to HOBt in suppressing racemization.<sup>[1][8][9][11]</sup>
- **Analyze Your Base:** The choice and amount of base are critical.
  - **Problem:** Strong, sterically unhindered bases (like triethylamine) can directly abstract the  $\alpha$ -proton, causing racemization.<sup>[9]</sup> Excess base also accelerates oxazolone formation.

- Solution: Use a weaker, sterically hindered base like N,N-Diisopropylethylamine (DIPEA) or 2,4,6-Collidine (TMP).[6][9][12] Use the minimum amount necessary—typically 1-2 equivalents.

Q2: The coupling of my Fmoc-Trp(dansyl)-OH is very slow and gives a low yield. I'm worried that increasing the reaction time or temperature will cause racemization.

A2: Your concern is valid. Both prolonged reaction times and elevated temperatures increase the risk of racemization.[2] The goal is to accelerate the desired coupling event so it outcompetes the racemization pathway.

Troubleshooting Steps:

- Switch to a High-Reactivity Reagent: This is the most effective solution.
  - Solution: Use HATU or COMU. These reagents form highly reactive esters that can overcome the steric hindrance of bulky fluorescent amino acids, leading to faster, more efficient coupling with minimal racemization.[4][6][7][8]
- Optimize Pre-activation Time: Pre-activating the amino acid with the coupling reagent before adding it to the resin can be beneficial, but prolonged pre-activation can be detrimental.
  - Solution: Keep pre-activation times short (1-5 minutes).[4][5] This ensures the activated species is generated but doesn't have excessive time to racemize before the amine is available for coupling.
- Consider Microwave-Assisted Peptide Synthesis (MA-SPPS): Microwave energy can dramatically accelerate coupling reactions.
  - Solution: Use a microwave synthesizer. However, be cautious with temperature. For racemization-prone residues like derivatives of Cys and His, it may be necessary to lower the coupling temperature (e.g., from 75°C to 50°C) or perform that specific coupling step at room temperature.[4][12]

Q3: I need to couple a fluorescent phenylalanine derivative. Are certain amino acids more prone to racemization?

A3: Yes. While any amino acid can racemize under suboptimal conditions, some are particularly susceptible. Histidine (His) and Cysteine (Cys) are notoriously prone to racemization.[12][13] Phenylalanine can also be problematic.[2] The risk is amplified when these residues are modified with bulky fluorescent tags.

Preventative Strategy:

- For His derivatives: Ensure the imidazole side chain is appropriately protected (e.g., with a Trityl (Trt) group).[14]
- For Cys derivatives: Use milder activation conditions and consider coupling at a lower temperature.[12]
- General Strategy: For any sensitive fluorescent amino acid, using a combination of a high-efficiency coupling reagent (e.g., COMU) with an Oxyma-based additive and a hindered base (DIPEA) is the gold standard for preventing racemization.[8]

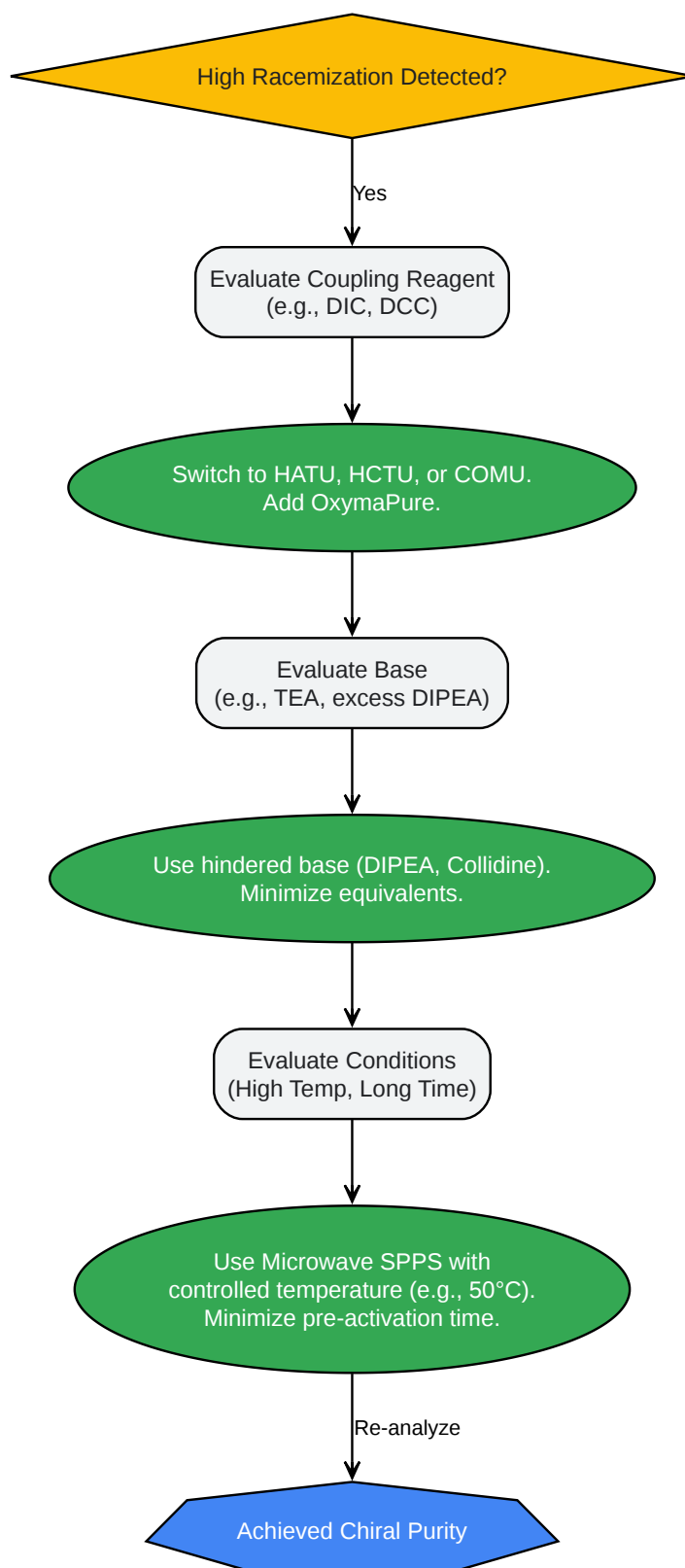

[Click to download full resolution via product page](#)

Caption: Decision workflow for troubleshooting high racemization.

## Quantitative Data: Comparison of Coupling Reagents

The choice of coupling reagent and additive has the most significant impact on racemization levels. The following table provides a comparative overview.

Coupling Method	Relative Reactivity	Racemization Risk	Key Advantages	Considerations
DIC / HOBt	Medium	Medium	Cost-effective, widely used.	Can be insufficient for hindered amino acids; HOBt has safety/shipping restrictions.[7][15]
DIC / OxymaPure	Medium-High	Low	Excellent racemization suppression, safer than HOBt.[8][9][15]	Superior modern alternative to HOBt.
HBTU / DIPEA	High	Medium-Low	Fast and efficient for standard couplings.[4][6][7]	Can still cause racemization in sensitive cases; risk of guanidinylation side reaction.[13]
HATU / DIPEA	Very High	Low	Highly effective for hindered amino acids, low racemization.[4][5][7]	Higher cost. Based on HOAt, which has safety concerns.
COMU / DIPEA	Very High	Very Low	Considered one of the best for suppressing racemization, especially for difficult couplings. Safe (non-explosive).[6][8]	Highest cost, but often justified for critical steps.

---

Acyl Fluoride	High	Very Low	Excellent for extremely hindered couplings where other methods fail. <a href="#">[5]</a> <a href="#">[16]</a>	Requires a two-step process to form the acyl fluoride first.
---------------	------	----------	---	--

---

Note: This data is illustrative. Results can vary based on the specific amino acid, solvent, and base used.[\[2\]](#)

## Experimental Protocols

### Protocol 1: High-Efficiency, Low-Racemization Coupling using COMU

This protocol is recommended for coupling bulky, fluorescent, or otherwise racemization-prone amino acids during Fmoc-based Solid-Phase Peptide Synthesis (SPPS).

#### Materials:

- Fmoc-protected fluorescent amino acid
- Peptide-resin with free N-terminal amine
- COMU (1-(1-Cyano-2-ethoxy-2-oxoethylideneaminoxy)dimethylamino-morpholinocarbenium hexafluorophosphate)
- DIPEA (N,N-Diisopropylethylamine)
- DMF (N,N-Dimethylformamide), peptide synthesis grade

#### Procedure:

- Resin Preparation: Following standard Fmoc deprotection of the resin-bound peptide, wash the resin thoroughly with DMF (3 x 10 mL/g resin).
- Coupling Solution Preparation (Pre-activation):

- In a separate vessel, dissolve the Fmoc-fluorescent amino acid (3.0 eq. relative to resin loading) in DMF.
- Add COMU (3.0 eq.) to the amino acid solution and mix briefly.
- Add DIPEA (6.0 eq.) to the solution.
- Allow the solution to pre-activate for 2 minutes at room temperature. Do not exceed 5 minutes.
- Coupling Reaction:
  - Add the pre-activated coupling solution to the washed peptide-resin.
  - Agitate the mixture at room temperature for 1-2 hours. For particularly hindered amino acids, the time can be extended, but monitor for completeness.
- Monitoring: Perform a Kaiser test to confirm the absence of free primary amines, indicating reaction completion.[4]
- Post-Coupling Wash: Once the reaction is complete, drain the reaction vessel and wash the resin thoroughly with DMF (3x), DCM (3x), and DMF (3x) to remove all soluble reagents and by-products.

## Frequently Asked Questions (FAQs)

Q1: Why are urethane protecting groups like Fmoc and Boc preferred for minimizing racemization? A1: Urethane-based protecting groups (Fmoc, Boc, Z-group) are specifically designed to suppress racemization. The electronic structure of the urethane bond makes the  $N\alpha$ -proton less acidic and disfavors the formation of the oxazolone intermediate compared to simple acyl protecting groups.[2][6]

Q2: Can the solvent choice affect racemization? A2: Yes. The solvent plays a role in solvating the reactants and intermediates. While DMF is the most common solvent, for particularly aggregation-prone sequences, N-Methylpyrrolidone (NMP) may offer superior solvating properties.[5] In some cases, less polar solvents like Dichloromethane (DCM) may slightly reduce racemization, but this must be balanced with solubility requirements.[2]

Q3: Is it ever acceptable to perform a coupling at an elevated temperature? A3: Elevated temperatures can be very effective for driving difficult couplings to completion, especially with microwave assistance.[5][12] However, it is a trade-off. For amino acids not prone to racemization, temperatures of 75-90°C are common in microwave SPPS. For sensitive fluorescent amino acids (e.g., derivatives of His, Cys, Ser), it is highly advisable to reduce the temperature to 50°C or perform the coupling at room temperature to minimize the risk.[12]

Q4: I'm performing a segment condensation (coupling two peptide fragments), is the risk of racemization higher? A4: Yes, the risk is significantly higher. When activating a peptide fragment, the C-terminal amino acid is no longer protected by a urethane group but by the preceding amino acid (an acyl group). This structure is highly susceptible to racemization via the oxazolone pathway.[6] For fragment condensations, it is absolutely critical to use advanced, low-racemization coupling reagent systems like DIC/Oxyma or COMU.

## References

- Aggregation, Racemization and Side Reactions in Peptide Synthesis. (Source: AAPPTEC) URL: [\[Link\]](#)
- Palasek, S. A., et al. (2007). Limiting racemization and aspartimide formation in microwave-enhanced Fmoc solid phase peptide synthesis. *Journal of Peptide Science*. URL: [\[Link\]](#)
- Due-Hansen, M. E., et al. (2015). A protocol for amide bond formation with electron deficient amines and sterically hindered substrates. *Organic & Biomolecular Chemistry*. URL: [\[Link\]](#)
- Subirós-Funosas, R., et al. (2022). Understanding OxymaPure as a Peptide Coupling Additive: A Guide to New Oxyma Derivatives. *ACS Omega*. URL: [\[Link\]](#)
- Williams, M. W., & Young, G. T. (1964). The Mechanism of Racemisation during the Coupling of Acylpeptides. *Journal of the Chemical Society*. URL: [\[Link\]](#)
- Coupling Reagents for Peptide Synthesis. (Source: AAPPTEC) URL: [\[Link\]](#)
- Jad, Y. E., et al. (2023). Suppression of alpha-carbon racemization in peptide synthesis based on a thiol-labile amino protecting group. *Nature Communications*. URL: [\[Link\]](#)

- Fields, G. B., et al. (1997). Analysis of Racemization During "Standard" Solid Phase Peptide Synthesis: A Multicenter Study. Techniques in Protein Chemistry VIII. URL: [\[Link\]](#)
- The Role of HOBt and HBTU in Peptide Coupling Reactions. (Source: Acade Chemical) URL: [\[Link\]](#)
- Planning a Peptide Synthesis. (Source: AAPPTEC) URL: [\[Link\]](#)
- Del Valle, P., & Goodman, M. (2020). Epimerisation in Peptide Synthesis. Molecules. URL: [\[Link\]](#)
- Subirós-Funosas, R., et al. (2022). Understanding OxymaPure as a Peptide Coupling Additive: A Guide to New Oxyma Derivatives. ACS Omega. URL: [\[Link\]](#)
- Racemization during SPPS coupling step. (Source: ResearchGate) URL: [\[Link\]](#)
- Katritzky, A. R., et al. (2010). Efficient Peptide Coupling Involving Sterically Hindered Amino Acids. The Journal of Organic Chemistry. URL: [\[Link\]](#)
- Del Valle, P., & Goodman, M. (2020). Epimerisation in Peptide Synthesis. National Institutes of Health. URL: [\[Link\]](#)
- Liang, C., et al. (2017). Phenylglycine racemization in Fmoc-based solid-phase peptide synthesis: Stereochemical stability is achieved by choice of reaction conditions. Tetrahedron Letters. URL: [\[Link\]](#)
- Albericio, F., & El-Faham, A. (2018). Choosing the Right Coupling Reagent for Peptides: A Twenty-Five-Year Journey. Organic Process Research & Development. URL: [\[Link\]](#)

### ***Need Custom Synthesis?***

*BenchChem offers custom synthesis for rare earth carbides and specific isotopic labeling.*

*Email: [info@benchchem.com](mailto:info@benchchem.com) or [Request Quote Online](#).*

## Sources

- [1. pdf.benchchem.com](https://pdf.benchchem.com) [[pdf.benchchem.com](https://pdf.benchchem.com)]

- [2. pdf.benchchem.com \[pdf.benchchem.com\]](#)
- [3. mdpi.com \[mdpi.com\]](#)
- [4. pdf.benchchem.com \[pdf.benchchem.com\]](#)
- [5. pdf.benchchem.com \[pdf.benchchem.com\]](#)
- [6. bachem.com \[bachem.com\]](#)
- [7. peptide.com \[peptide.com\]](#)
- [8. Understanding OxymaPure as a Peptide Coupling Additive: A Guide to New Oxyma Derivatives - PMC \[pmc.ncbi.nlm.nih.gov\]](#)
- [9. A Brief Introduction to the Racemization of Amino Acids in Polypeptide Synthesis \[en.highfine.com\]](#)
- [10. The Role of HOBt and HBTU in Peptide Coupling Reactions - Creative Peptides \[creative-peptides.com\]](#)
- [11. pubs.acs.org \[pubs.acs.org\]](#)
- [12. Limiting racemization and aspartimide formation in microwave-enhanced Fmoc solid phase peptide synthesis - PubMed \[pubmed.ncbi.nlm.nih.gov\]](#)
- [13. peptide.com \[peptide.com\]](#)
- [14. peptide.com \[peptide.com\]](#)
- [15. merckmillipore.com \[merckmillipore.com\]](#)
- [16. A protocol for amide bond formation with electron deficient amines and sterically hindered substrates - Organic & Biomolecular Chemistry \(RSC Publishing\) DOI:10.1039/C5OB02129D \[pubs.rsc.org\]](#)
- To cite this document: BenchChem. [How to avoid racemization during fluorescent amino acid coupling]. BenchChem, [2026]. [Online PDF]. Available at: [\[https://www.benchchem.com/product/b613415/docs#how-to-avoid-racemization-during-fluorescent-amino-acid-coupling\]](https://www.benchchem.com/product/b613415/docs#how-to-avoid-racemization-during-fluorescent-amino-acid-coupling)

---

### Disclaimer & Data Validity:

The information provided in this document is for Research Use Only (RUO) and is strictly not intended for diagnostic or therapeutic procedures. While BenchChem strives to provide accurate protocols, we make no warranties, express or implied, regarding the fitness of this product for every specific experimental setup.

**Technical Support:** The protocols provided are for reference purposes. Unsure if this reagent suits your experiment?

**Need Industrial/Bulk Grade?** [Request Custom Synthesis Quote](#)

## BenchChem

Our mission is to be the trusted global source of essential and advanced chemicals, empowering scientists and researchers to drive progress in science and industry.

### Contact

Address: 3281 E Guasti Rd  
Ontario, CA 91761, United States  
Phone: (601) 213-4426  
Email: [info@benchchem.com](mailto:info@benchchem.com)

[Contact our Ph.D. Support Team for a compatibility check](#)