

H-His-NH₂·2HCl chemical properties and structure

Author: BenchChem Technical Support Team. **Date:** December 2025

Compound of Interest

Compound Name: *H-His-NH₂·2HCl*

Cat. No.: *B613043*

[Get Quote](#)

An In-depth Technical Guide to L-Histidinamide Dihydrochloride (H-His-NH₂·2HCl)

For Researchers, Scientists, and Drug Development Professionals

Introduction

L-Histidinamide dihydrochloride (H-His-NH₂·2HCl) is the dihydrochloride salt of L-Histidinamide, an amino acid derivative of L-Histidine. In peptide chemistry, the "H-" prefix denotes a free amino group at the N-terminus, and "-NH₂" signifies a carboxamide group at the C-terminus. This compound is a valuable building block in biochemical research and pharmaceutical development.^[1] It serves as a precursor in the synthesis of peptides and other complex molecules and is utilized in cell culture media formulations.^[1]

It is crucial to distinguish L-Histidinamide dihydrochloride from Histamine dihydrochloride, the decarboxylation product of L-Histidine. While structurally related, they are distinct compounds with different chemical properties and biological activities. This guide will focus exclusively on the properties and structure of L-Histidinamide dihydrochloride.

Chemical Structure and Properties

L-Histidinamide dihydrochloride is characterized by a protonated α -amino group, an imidazole side chain, and a C-terminal amide. The dihydrochloride salt form generally ensures higher solubility in aqueous solutions.^[1]

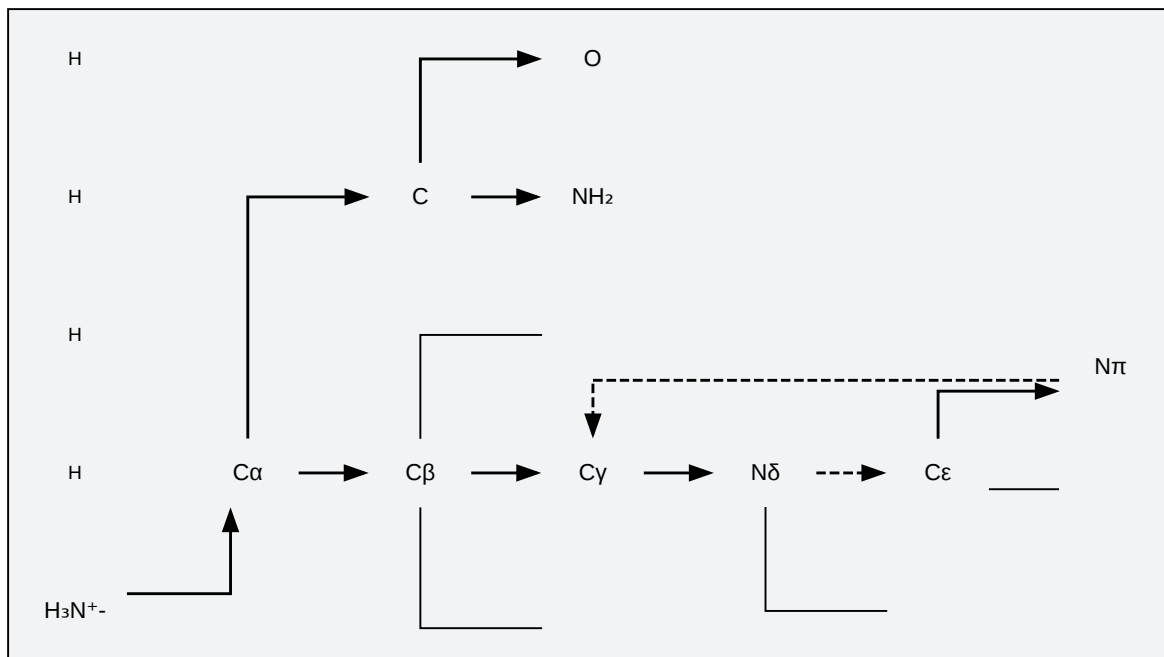

2Cl⁻

[Click to download full resolution via product page](#)

Caption: Chemical Structure of L-Histidinamide Dihydrochloride

Physicochemical Properties

Quantitative data for L-Histidinamide dihydrochloride is not as widely published as for its parent amino acid, L-Histidine. The following table summarizes available data for L-Histidinamide dihydrochloride and related compounds for comparison.

Property	L-Histidinamide Dihydrochloride (H-His-NH ₂ ·2HCl)	L-Histidine (Parent Compound)
CAS Number	71666-95-0	71-00-1
Molecular Formula	C ₆ H ₁₂ Cl ₂ N ₄ O	C ₆ H ₉ N ₃ O ₂
Molecular Weight	227.09 g/mol	155.15 g/mol [2]
Appearance	Solid	White crystalline or crystalline powder[3]
Melting Point	Data not available	~282-288 °C (decomposes)[2] [3]
Solubility	Soluble in DMSO.[4][5]	Soluble in water (4.3 g/100 mL at 25°C); very slightly soluble in ethanol; insoluble in ether.[3]
pKa Values (at 25°C)	Data not available	pKa ₁ (α-carboxyl) = 1.80pKa ₂ (imidazole) = 6.04pKa ₃ (α-amino) = 9.33[6][7]

Biological Activity and Applications

L-Histidinamide dihydrochloride is primarily used as a chemical intermediate and building block in research and development.[1][8]

Role in Drug Delivery

A significant application of L-Histidinamide is in advanced drug delivery systems. Recently, it was used to synthesize an ionizable cholesterol analog, 3β[L-histidinamide-carbamoyl] cholesterol (Hchol).[5][9] When incorporated into lipid nanoparticles (LNPs), Hchol enhances the intracellular delivery of mRNA.[9]

The imidazole side chain of histidine has a pKa near physiological pH, allowing it to act as a proton sponge.[6][7] In the acidic environment of the endosome, the imidazole group becomes protonated. This charge reversal is believed to destabilize the endosomal membrane, facilitating the release of the LNP's cargo (e.g., mRNA) into the cytoplasm. This mechanism,

known as endosomal escape, is a critical step for the efficacy of many nanomedicines.^{[5][9]}
The pKa values of LNPs formulated with Hchol were found to be approximately 6.03 and 6.61, which is optimal for this effect.^[9]

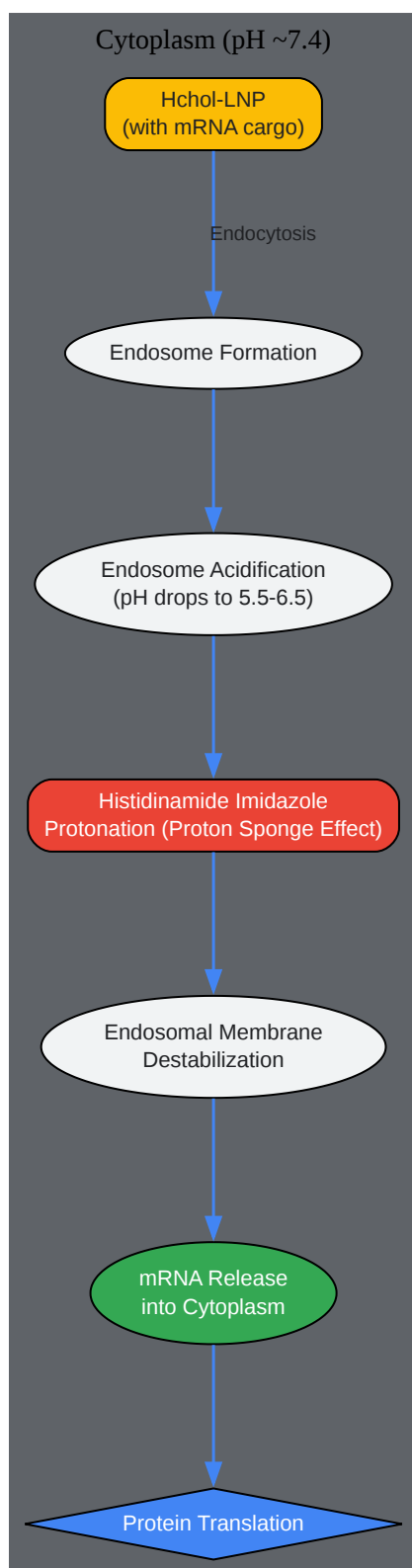

[Click to download full resolution via product page](#)

Caption: Enhanced mRNA delivery via Hchol-LNP endosomal escape.

Other Research Applications

- **Biochemical Research:** It serves as a building block for synthesizing peptides and proteins for studying enzyme functions and cellular processes.[1]
- **Pharmaceutical Development:** The compound is explored for its role as a precursor in the synthesis of various therapeutic agents.[1][8]
- **Cell Culture:** It is used as a component in cell culture media to support cell growth and viability.[1]

Experimental Protocols

Representative Synthesis of L-Histidinamide Dihydrochloride

The synthesis of L-Histidinamide typically involves the protection of the amino and imidazole groups of L-Histidine, followed by the amidation of the carboxylic acid, and subsequent deprotection. A generalized workflow is presented below.

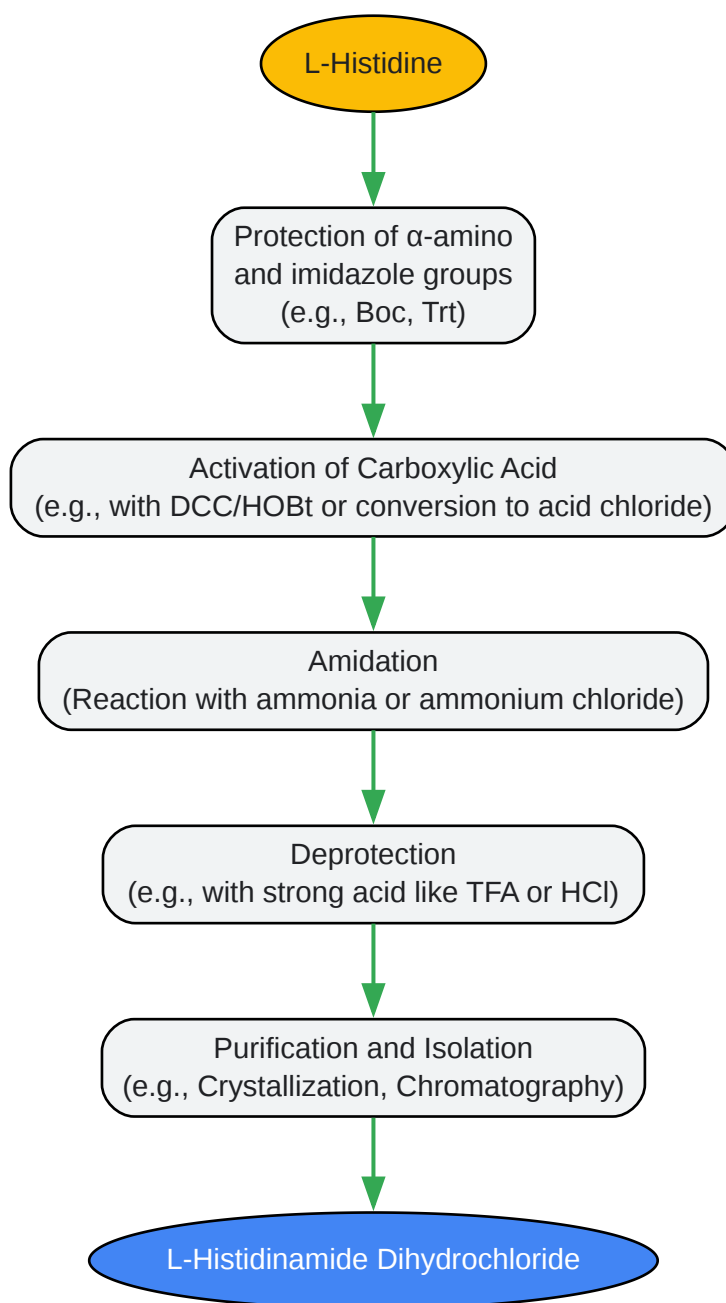

[Click to download full resolution via product page](#)

Caption: Generalized workflow for the synthesis of H-His-NH₂·2HCl.

Methodology Outline:

- Protection: The α-amino group and the imidazole nitrogen of L-Histidine are protected using standard protecting groups (e.g., Boc for the amino group, Trt or DNP for the imidazole ring) to prevent side reactions.

- **Activation & Amidation:** The carboxylic acid group is activated, often by conversion to an active ester or acid chloride. This activated intermediate is then reacted with a source of ammonia to form the amide.
- **Deprotection and Salt Formation:** The protecting groups are removed, typically under acidic conditions (e.g., using trifluoroacetic acid or hydrochloric acid). Treatment with excess hydrochloric acid followed by precipitation from a non-polar solvent (like ether) or crystallization yields the final L-Histidinamide dihydrochloride salt.[10]
- **Purification:** The final product is purified by recrystallization to remove any remaining starting materials or byproducts.[11] The purity can be assessed by techniques like TLC, HPLC, and NMR.

Content Analysis (Titration)

A common method for quantifying L-Histidine derivatives is non-aqueous titration.

Protocol:

- Accurately weigh the sample (approx. 105 mg) after drying.
- Dissolve the sample in 3 mL of formic acid and 50 mL of glacial acetic acid.
- Titrate the solution with 0.1 M perchloric acid.
- Determine the endpoint using a potentiometer.
- A blank titration should be performed for correction. Each mL of 0.1 M perchloric acid is equivalent to 15.52 mg of L-Histidine.[3]

Safety and Handling

L-Histidinamide dihydrochloride should be handled by personnel trained in laboratory procedures. Standard safety precautions should be observed.

- **Hazard Statements:** May cause skin, eye, and respiratory irritation.[4]
- **Precautionary Measures:**

- Avoid breathing dust.
- Wear protective gloves, eye protection, and face protection.[12]
- Use in a well-ventilated area.
- Store in a cool, dry place under an inert atmosphere.[13]

For detailed safety information, always refer to the Safety Data Sheet (SDS) provided by the supplier.

Need Custom Synthesis?

BenchChem offers custom synthesis for rare earth carbides and specific isotopic labeling.

Email: info@benchchem.com or [Request Quote Online](#).

References

- 1. chemimpex.com [chemimpex.com]
- 2. L-Histidine | C₆H₉N₃O₂ | CID 6274 - PubChem [pubchem.ncbi.nlm.nih.gov]
- 3. L-Histidine | 71-00-1 [chemicalbook.com]
- 4. L-Histidinol dihydrochloride | C₆H₁₃Cl₂N₃O | CID 197743 - PubChem [pubchem.ncbi.nlm.nih.gov]
- 5. researchgate.net [researchgate.net]
- 6. sigmaaldrich.com [sigmaaldrich.com]
- 7. sigmaaldrich.com [sigmaaldrich.com]
- 8. nbinno.com [nbinno.com]
- 9. Modulating Lipid Nanoparticles with Histidinamide-Conjugated Cholesterol for Improved Intracellular Delivery of mRNA - PubMed [pubmed.ncbi.nlm.nih.gov]
- 10. L-Histidine synthesis - chemicalbook [chemicalbook.com]
- 11. L-HISTIDINE MONOHYDROCHLORIDE MONOHYDRATE - Ataman Kimya [atamanchemicals.com]

- 12. L-Histidine dihydrochloride | C₆H₁₁Cl₂N₃O₂ | CID 72609 - PubChem [pubchem.ncbi.nlm.nih.gov]
- 13. usbio.net [usbio.net]
- To cite this document: BenchChem. [H-His-NH₂.2HCl chemical properties and structure]. BenchChem, [2025]. [Online PDF]. Available at: [https://www.benchchem.com/product/b613043#h-his-nh2-2hcl-chemical-properties-and-structure]

Disclaimer & Data Validity:

The information provided in this document is for Research Use Only (RUO) and is strictly not intended for diagnostic or therapeutic procedures. While BenchChem strives to provide accurate protocols, we make no warranties, express or implied, regarding the fitness of this product for every specific experimental setup.

Technical Support: The protocols provided are for reference purposes. Unsure if this reagent suits your experiment? [[Contact our Ph.D. Support Team for a compatibility check](#)]

Need Industrial/Bulk Grade? [Request Custom Synthesis Quote](#)

BenchChem

Our mission is to be the trusted global source of essential and advanced chemicals, empowering scientists and researchers to drive progress in science and industry.

Contact

Address: 3281 E Guasti Rd

Ontario, CA 91761, United States

Phone: (601) 213-4426

Email: info@benchchem.com