

FIIN-2: A Comprehensive Technical Guide to Downstream Signaling Pathways

Author: BenchChem Technical Support Team. **Date:** March 2026

Compound of Interest

Compound Name: FIIN-2
Cat. No.: B612009

[Get Quote](#)

For Researchers, Scientists, and Drug Development Professionals

Abstract

FIIN-2 is a potent, irreversible, pan-fibroblast growth factor receptor (FGFR) inhibitor that covalently targets a conserved cysteine residue in the P-loop of FGFRs 1, 2, 3, and 4.^[1] Its mechanism of action extends beyond FGFR inhibition, demonstrating a complex interplay with other signaling networks. This technical guide provides an in-depth analysis of the downstream signaling pathways modulated by **FIIN-2**, supported by quantitative data, detailed experimental methodologies, and visual pathway diagrams. This document is intended to serve as a comprehensive resource for researchers and professionals involved in oncology drug discovery and development.

Core Mechanism of Action: FGFR Inhibition

FIIN-2 exerts its primary anti-tumor effects by irreversibly binding to and inhibiting the kinase activity of all four FGFR family members. This covalent interaction effectively blocks the ATP-binding pocket, preventing receptor autophosphorylation and the subsequent activation of downstream signaling cascades.

Quantitative Inhibition Profile

The inhibitory potency of **FIIN-2** against the wild-type FGFR family and key off-targets has been determined through various biochemical and cellular assays.



FULL PROTOCOL TRUNCATED

To view exact molar ratios, purification steps, and HRP optimization data, please view the interactive version.

[Unlock Full Protocol on Website](#)

Canonical FGFR Downstream Signaling Pathways Modulated by FIIN-2

The inhibition of FGFR by **FIIN-2** leads to the downregulation of several critical signaling pathways involved in cell proliferation, survival, and differentiation.

RAS/RAF/MEK/MAPK Pathway

The MAPK pathway is a central regulator of cell proliferation. **FIIN-2** effectively suppresses this pathway by inhibiting FGFR-mediated activation of FRS2, which in turn prevents the recruitment of the GRB2-SOS complex and subsequent activation of RAS and ERK.



FULL PROTOCOL TRUNCATED

To view exact molar ratios, purification steps, and HRP optimization data, please view the interactive version.

[Unlock Full Protocol on Website](#)

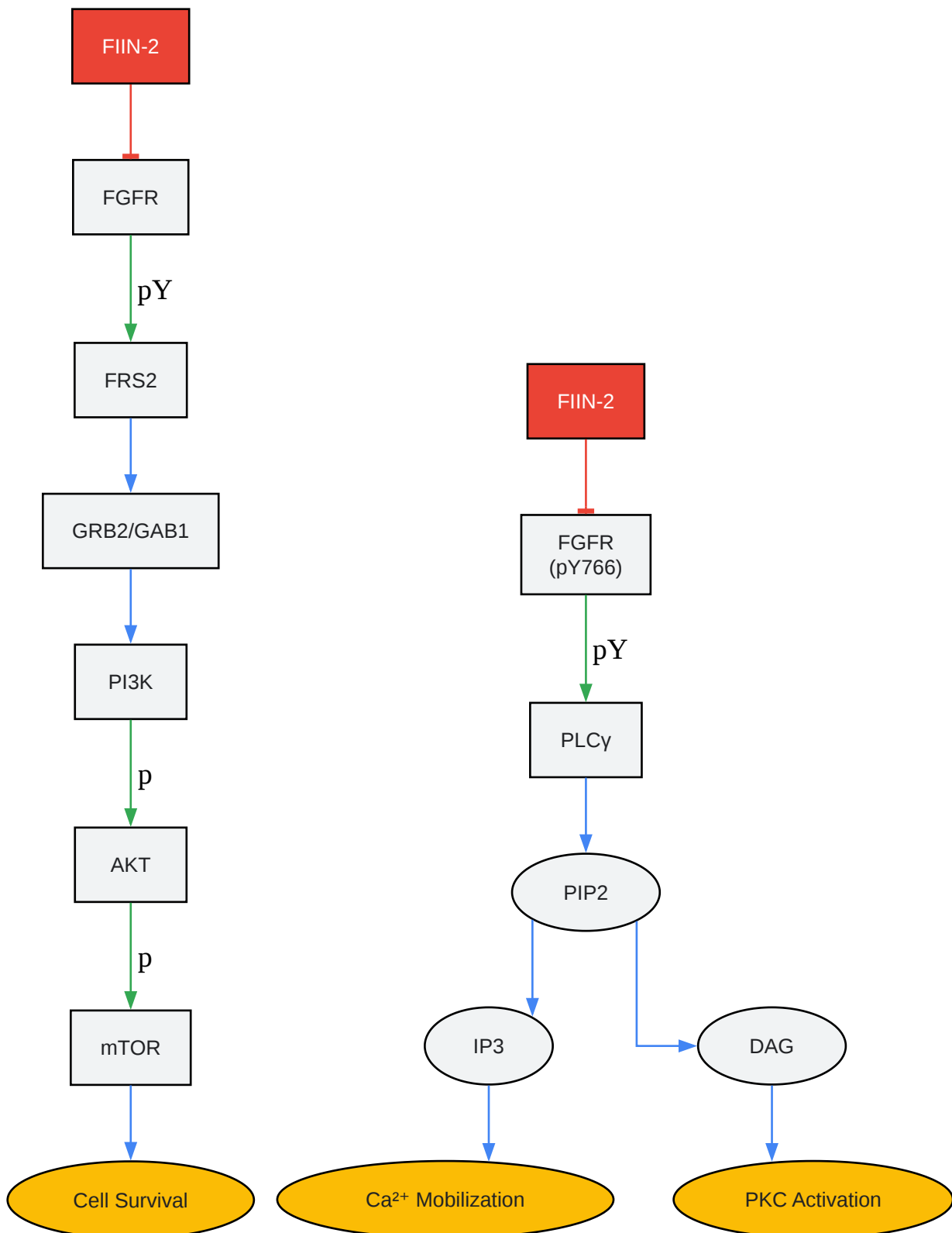

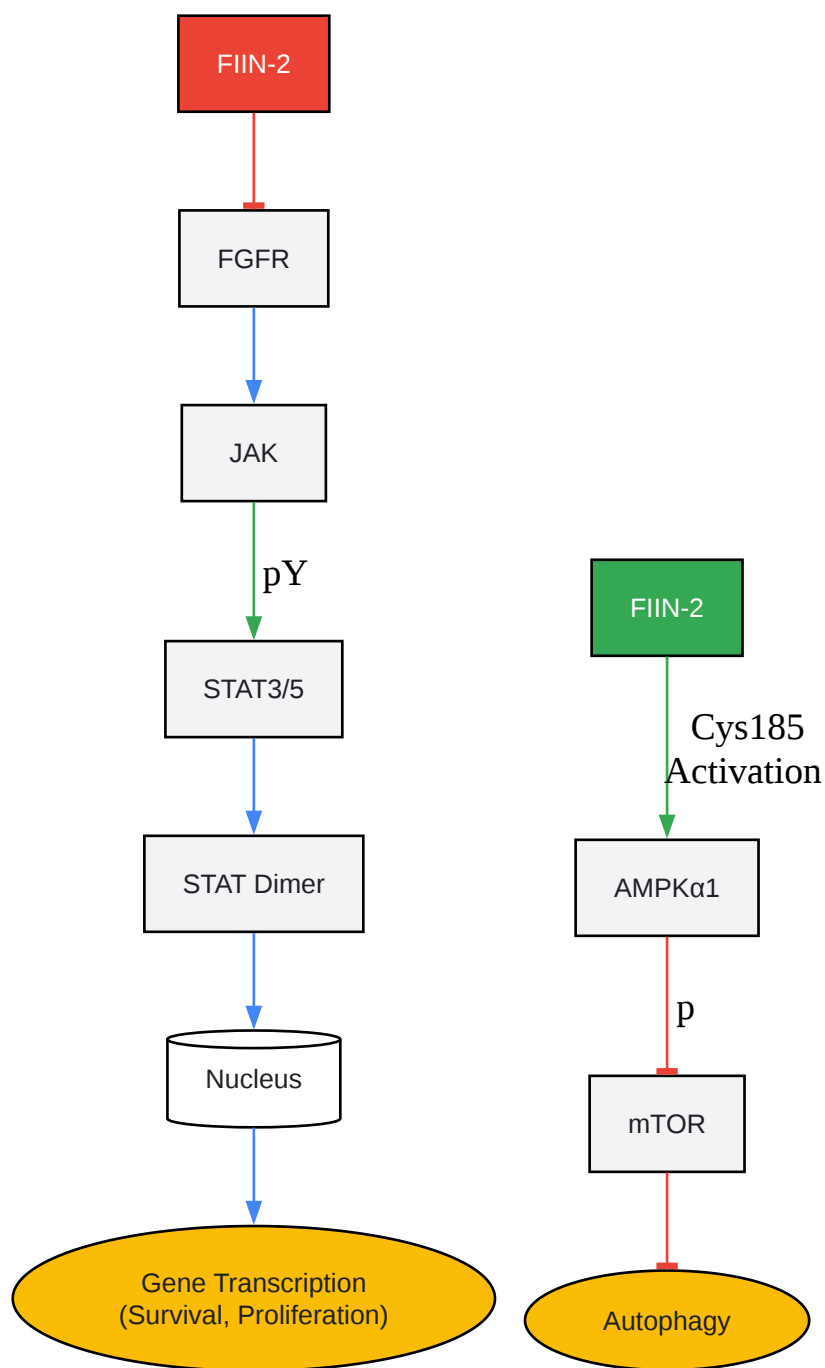

[Click to download full resolution via product page](#)

Need Custom Synthesis?

BenchChem offers custom synthesis for rare earth carbides and specific isotopic labeling.

Email: info@benchchem.com or [Request Quote Online](#).

References

- [1. Integrative Multi-Omics Approaches Reveal Selectivity Profiles and Molecular Mechanisms of FIIN-2, a Covalent FGFR Inhibitor - PMC \[pmc.ncbi.nlm.nih.gov\]](#)
- [2. medchemexpress.com \[medchemexpress.com\]](#)
- [3. In vitro NLK Kinase Assay - PMC \[pmc.ncbi.nlm.nih.gov\]](#)
- To cite this document: BenchChem. [FIIN-2: A Comprehensive Technical Guide to Downstream Signaling Pathways]. BenchChem, [2026]. [Online PDF]. Available at: [<https://www.benchchem.com/product/b612009#fiin-2-downstream-signaling-pathways>]

Disclaimer & Data Validity:

The information provided in this document is for Research Use Only (RUO) and is strictly not intended for diagnostic or therapeutic procedures. While BenchChem strives to provide accurate protocols, we make no warranties, express or implied, regarding the fitness of this product for every specific experimental setup.

Technical Support: The protocols provided are for reference purposes. Unsure if this reagent suits your experiment?

Need Industrial/Bulk Grade? [Request Custom Synthesis Quote](#)

BenchChem

Our mission is to be the trusted global source of essential and advanced chemicals, empowering scientists and researchers to drive progress in science and industry.

Contact

Address: 3281 E Guasti Rd
Ontario, CA 91761, United States
Phone: (601) 213-4426
Email: info@benchchem.com

Contact our Ph.D. Support Team for a compatibility check