

# Application Notes and Protocols: Synthesis of Alisporivir Intermediate-1

**Author:** BenchChem Technical Support Team. **Date:** April 2026

## Compound of Interest

Compound Name: *Alisporivir intermediate-1*

Cat. No.: *B612759*

[Get Quote](#)

For Researchers, Scientists, and Drug Development Professionals

These application notes provide detailed protocols for the synthesis of a key intermediate in the preparation of Alisporivir, a non-immunosuppressive cyclophilin inhibitor with potent antiviral activity. Alisporivir is a semi-synthetic derivative of Cyclosporine A. The following protocols are based on established synthetic routes.

## Introduction

Alisporivir (also known as Debio-025) is a cyclosporine A analog that has been investigated for its therapeutic potential against various viral infections, including hepatitis C. Its mechanism of action involves the inhibition of cyclophilin A, a host protein essential for the replication of several viruses. The synthesis of Alisporivir involves the selective modification of the Cyclosporine A macrocycle. This document details the reaction conditions for the formation of a pivotal intermediate in this process, herein referred to as "**Alisporivir Intermediate-1**".

## Synthetic Pathway Overview

The synthesis of Alisporivir from Cyclosporine A can be summarized in the following key steps. "**Alisporivir Intermediate-1**" is generated in the initial step of this pathway.

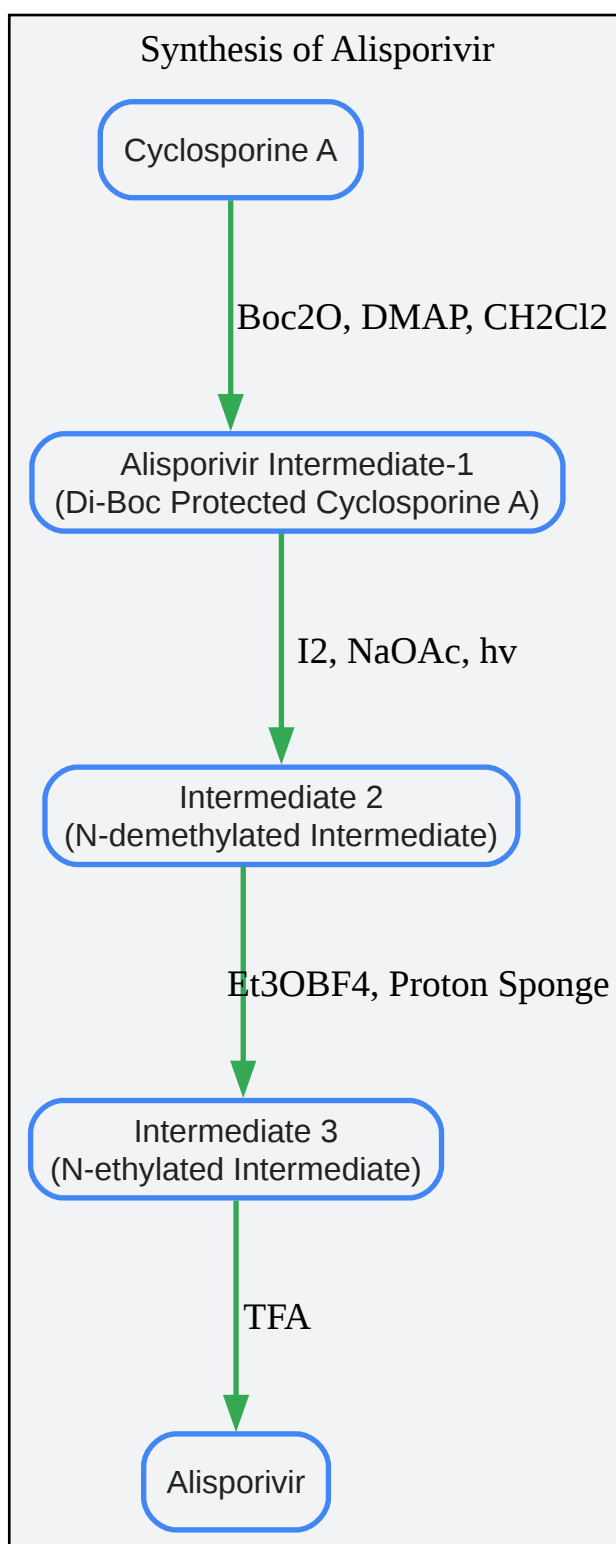

[Click to download full resolution via product page](#)

Caption: Synthetic workflow for Alisporivir from Cyclosporine A.

## Experimental Protocols

### Protocol 1: Synthesis of Alisporivir Intermediate-1 (Di-Boc Protected Cyclosporine A)

This protocol describes the protection of the two hydroxyl groups of Cyclosporine A using di-tert-butyl dicarbonate (Boc<sub>2</sub>O) to yield **Alisporivir Intermediate-1**.

Materials:

- Cyclosporine A
- Di-tert-butyl dicarbonate (Boc<sub>2</sub>O)
- 4-(Dimethylamino)pyridine (DMAP)
- Dichloromethane (CH<sub>2</sub>Cl<sub>2</sub>)
- Saturated aqueous sodium bicarbonate (NaHCO<sub>3</sub>) solution
- Brine (saturated aqueous NaCl solution)
- Anhydrous sodium sulfate (Na<sub>2</sub>SO<sub>4</sub>)
- Silica gel for column chromatography
- Ethyl acetate
- Hexanes

Procedure:

- Dissolve Cyclosporine A (1 equivalent) in dichloromethane (CH<sub>2</sub>Cl<sub>2</sub>).
- To this solution, add 4-(dimethylamino)pyridine (DMAP, catalytic amount) and di-tert-butyl dicarbonate (Boc<sub>2</sub>O, 2.5 equivalents).
- Stir the reaction mixture at room temperature for 12-16 hours.

- Monitor the reaction progress by thin-layer chromatography (TLC).
- Upon completion, quench the reaction by adding saturated aqueous sodium bicarbonate ( $\text{NaHCO}_3$ ) solution.
- Separate the organic layer and wash it sequentially with water and brine.
- Dry the organic layer over anhydrous sodium sulfate ( $\text{Na}_2\text{SO}_4$ ), filter, and concentrate under reduced pressure.
- Purify the crude product by silica gel column chromatography using a gradient of ethyl acetate in hexanes to afford **Alisporivir Intermediate-1** as a white solid.

Quantitative Data Summary:

Parameter	Value
Starting Material	Cyclosporine A
Reagents	$\text{Boc}_2\text{O}$ , DMAP
Solvent	Dichloromethane ( $\text{CH}_2\text{Cl}_2$ )
Reaction Temperature	Room Temperature
Reaction Time	12-16 hours
Typical Yield	90-95%

## Alisporivir's Mechanism of Action: Signaling Pathway

Alisporivir exerts its antiviral effect by targeting the host protein, cyclophilin A (CypA). CypA is a peptidyl-prolyl isomerase that is co-opted by some viruses, such as Hepatitis C virus (HCV), to aid in viral protein folding and replication. Alisporivir binds to the active site of CypA, preventing its interaction with viral proteins like NS5A, thereby inhibiting viral replication.

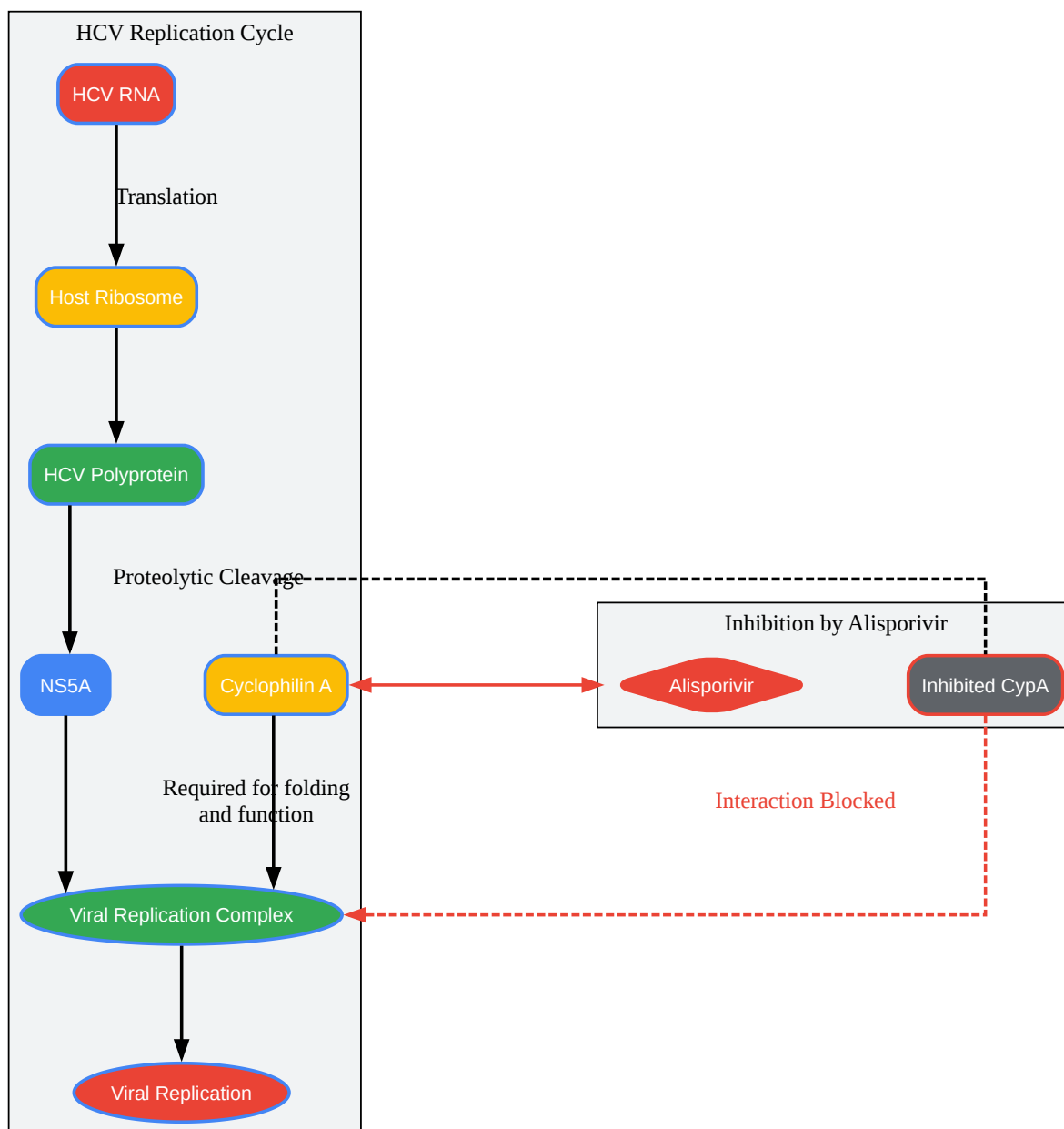

[Click to download full resolution via product page](#)

Caption: Inhibition of HCV replication by Alisporivir.

- To cite this document: BenchChem. [Application Notes and Protocols: Synthesis of Alisporivir Intermediate-1]. BenchChem, [2026]. [Online PDF]. Available at: [<https://www.benchchem.com/product/b612759/docs#application-notes-and-protocols-synthesis-of-alisporivir-intermediate-1>]

---

### Disclaimer & Data Validity:

The information provided in this document is for Research Use Only (RUO) and is strictly not intended for diagnostic or therapeutic procedures. While BenchChem strives to provide accurate protocols, we make no warranties, express or implied, regarding the fitness of this product for every specific experimental setup.

**Technical Support:** The protocols provided are for reference purposes. Unsure if this reagent suits your experiment?

**Need Industrial/Bulk Grade?** [Request Custom Synthesis Quote](#)

## BenchChem

Our mission is to be the trusted global source of essential and advanced chemicals, empowering scientists and researchers to drive progress in science and industry.

### Contact

Address: 3281 E Guasti Rd  
Ontario, CA 91761, United States  
Phone: (601) 213-4426  
Email: [info@benchchem.com](mailto:info@benchchem.com)

[Contact our Ph.D. Support Team for a compatibility check](#)