

# Application Notes & Protocols: Leveraging cef3 Mutants for Enhanced Biofuel Production

**Author:** BenchChem Technical Support Team. **Date:** May 2026

## Compound of Interest

Compound Name: CEF3  
Cat. No.: B612712

[Get Quote](#)

For Researchers, Scientists, and Drug Development Professionals

These application notes provide a comprehensive overview and detailed protocols for utilizing **cef3** (culm easily fragile 3) mutants to improve the efficiency of biofuel production from lignocellulosic biomass. The protocols are based on findings from research on the **cef3** mutant in rice (*Oryza sativa*), which has demonstrated a significant enhancement in enzymatic saccharification, a critical step in converting biomass to biofuels.

## Introduction

The recalcitrance of plant cell walls, particularly the secondary cell walls (SCWs), presents a major obstacle to cost-effective biofuel production. The complex structure of cellulose, hemicellulose, and lignin makes it difficult to break down into fermentable sugars. The **cef3** mutant in rice offers a promising genetic target to address this challenge. The **CEF3** gene encodes a protein homologous to Arabidopsis STOMATAL CYTOKINESIS DEFECTIVE2 (SCD2) and is involved in membrane trafficking, which is essential for the biosynthesis of secondary cell wall components like cellulose.<sup>[1][2][3]</sup> Mutation of the **CEF3** gene leads to altered cell wall composition, specifically a reduction in cellulose content, which in turn enhances the efficiency of enzymatic saccharification.<sup>[1][2]</sup>

## Key Findings and Data Presentation

The primary advantage of using **cef3** mutants is the increased yield of fermentable sugars from biomass. Research has shown that the sugar yields from the lignocellulosic material of **cef3** mutants are significantly higher than that of wild-type (WT) plants.[1]

Parameter	Wild-Type (WT)	cef3 Mutant	Fold Increase	Reference
Relative Glucose Yield	1.0	~1.5	~1.5x	[1]
Relative Xylose Yield	1.0	~1.7	~1.7x	[1]

Note: The exact quantitative values can be found in the supplementary materials of the cited research. The table provides a summary of the reported improvements.

Phenotypically, **cef3** mutants exhibit several characteristic traits, including reduced plant height, smaller panicles, shortened internodes, and easily broken culms.[1] While these agronomic traits need to be considered for large-scale cultivation, the enhanced saccharification efficiency presents a significant advantage for biofuel applications.

## Signaling Pathway and Mechanism of Action

The **CEF3** protein is localized in the Golgi apparatus and is involved in endocytosis and membrane trafficking.[1][2] Its function is crucial for the proper biosynthesis of cellulose and other polysaccharides that constitute the secondary cell wall. A mutation in **CEF3** disrupts these processes, leading to a number of downstream effects:

- **Altered Gene Expression:** The expression of genes related to cellulose and xylan biosynthesis is downregulated in **cef3** mutants.[1]
- **Reduced Cellulose Synthase Abundance:** The mutation affects the abundance of the cellulose synthase catalytic subunit 9 (OsCESA9) in the plasma membrane and endomembrane systems.[1][2][3]

This disruption in the synthesis and deposition of cell wall components results in a modified secondary cell wall structure that is more amenable to enzymatic degradation.

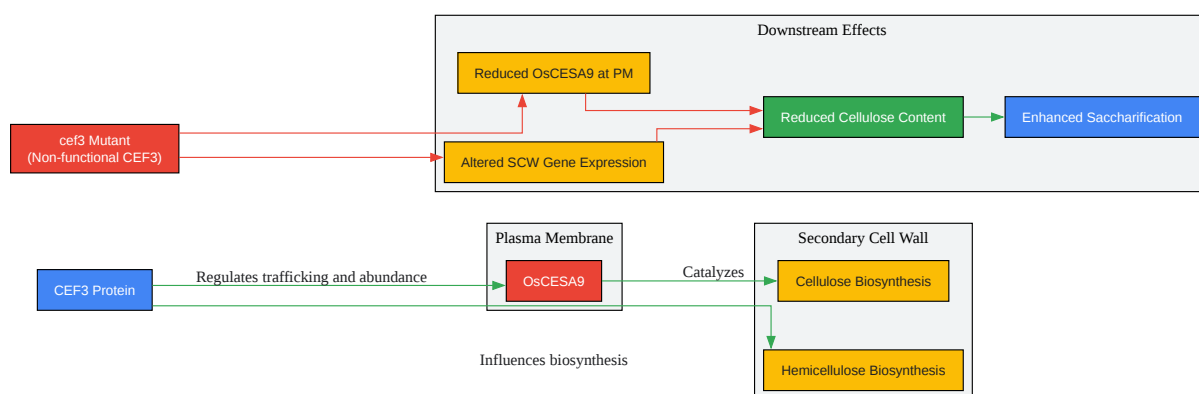

[Click to download full resolution via product page](#)

Caption: The **CEF3** signaling pathway and the effects of its mutation.

## Experimental Protocols

### Generation of **cef3** Mutants using CRISPR/Cas9

This protocol outlines the generation of **cef3** knockout mutants in rice using the CRISPR/Cas9 system.

Materials:

- CRISPR/Cas9 binary vectors (e.g., pYLCRISPR/Cas9Pubi-H for Cas9 and pYLgRNA for sgRNA)
- Agrobacterium tumefaciens strain (e.g., GV3101)
- Rice callus
- Co-cultivation and selection media
- PCR reagents for genotyping
- Sanger sequencing reagents

#### Procedure:

- Target Selection and sgRNA Design:
  - Identify the target gene sequence for **CEF3**.
  - Design a specific single guide RNA (sgRNA) targeting an exon of the **CEF3** gene. A potential target sequence in rice is TCAAACCAGCACGACATTG located in the second exon.<sup>[1]</sup>
  - Synthesize and clone the sgRNA into the sgRNA expression vector.
- Vector Construction and Transformation:
  - Construct the final binary vector containing both the Cas9 expression cassette and the sgRNA expression cassette.
  - Transform the binary vector into Agrobacterium tumefaciens.
- Agrobacterium-mediated Transformation of Rice Callus:
  - Induce callus formation from mature rice embryos.
  - Co-cultivate the rice callus with the transformed Agrobacterium.
  - Select for transformed calli on a selection medium containing an appropriate antibiotic.

- Regenerate whole plants from the transformed calli.
- Genotyping and Mutant Identification:
  - Extract genomic DNA from the regenerated plants (T0 generation).
  - Perform PCR using primers flanking the sgRNA target site.
  - Sequence the PCR products to identify mutations (insertions, deletions) at the target site.
  - Grow the T0 plants to maturity and screen the T1 generation to identify homozygous, transgene-free mutants.[4]

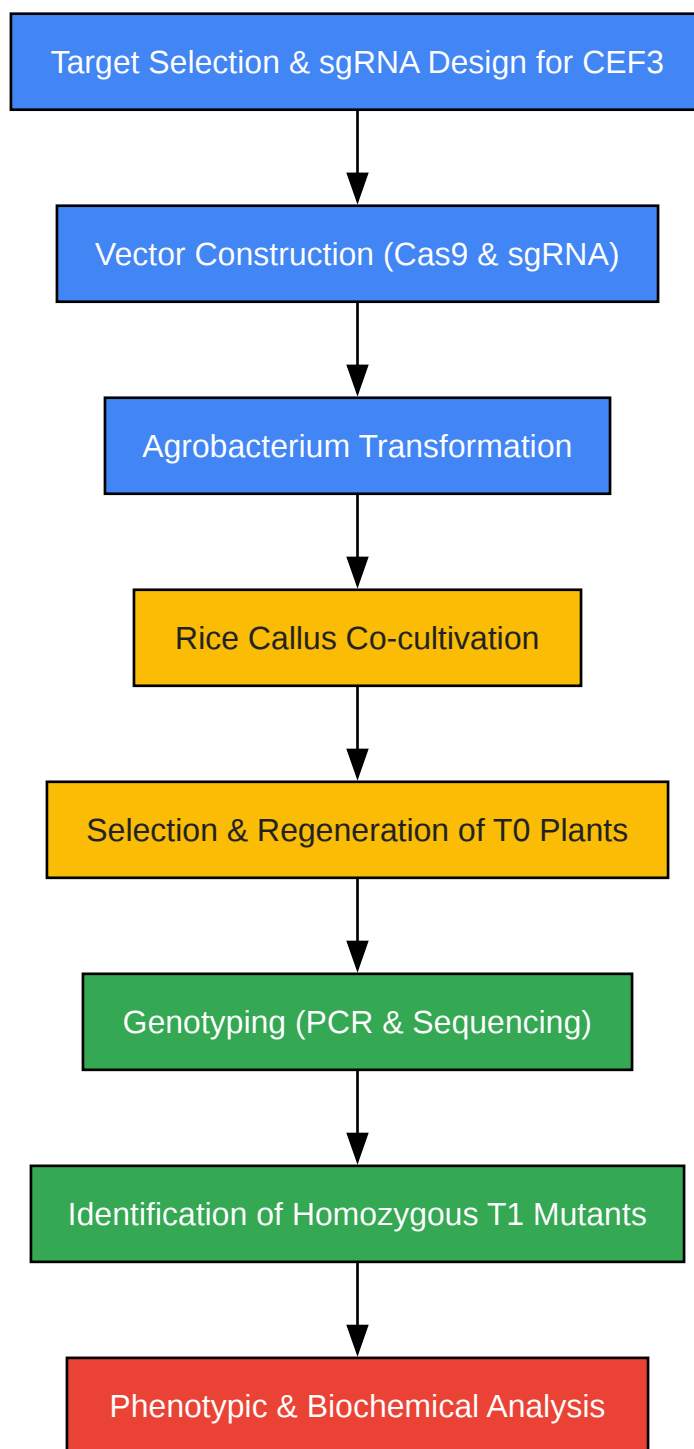

[Click to download full resolution via product page](#)

Caption: Workflow for generating and screening **cef3** mutants.

## Analysis of Enzymatic Saccharification Efficiency

This protocol describes the method to determine the sugar yield from the biomass of **cef3** mutants compared to wild-type plants.

Materials:

- Dried and ground rice straw (from both WT and **cef3** plants)
- Cellulase and xylanase enzyme cocktail
- Sodium acetate buffer (pH 4.8)
- Incubator shaker
- High-Performance Liquid Chromatography (HPLC) system with a refractive index detector
- Glucose and xylose standards

Procedure:

- Biomass Preparation:
  - Harvest mature rice straw, dry it at 60°C to a constant weight, and grind it into a fine powder.
- Enzymatic Hydrolysis:
  - Weigh a precise amount of the dried biomass powder (e.g., 50 mg) into a reaction tube.
  - Add a defined volume of sodium acetate buffer containing a mixture of cellulase and xylanase.
  - Incubate the mixture at a specified temperature (e.g., 50°C) with constant shaking for a set period (e.g., 48 hours).
- Sample Analysis:
  - After incubation, centrifuge the samples to pellet the remaining solids.
  - Filter the supernatant through a 0.22 µm filter.

- Analyze the concentration of glucose and xylose in the supernatant using an HPLC system.
- Data Calculation:
  - Calculate the sugar yield as the amount of sugar released per gram of dry biomass.
  - Compare the sugar yields from **cef3** mutants and WT plants to determine the relative improvement in saccharification efficiency.

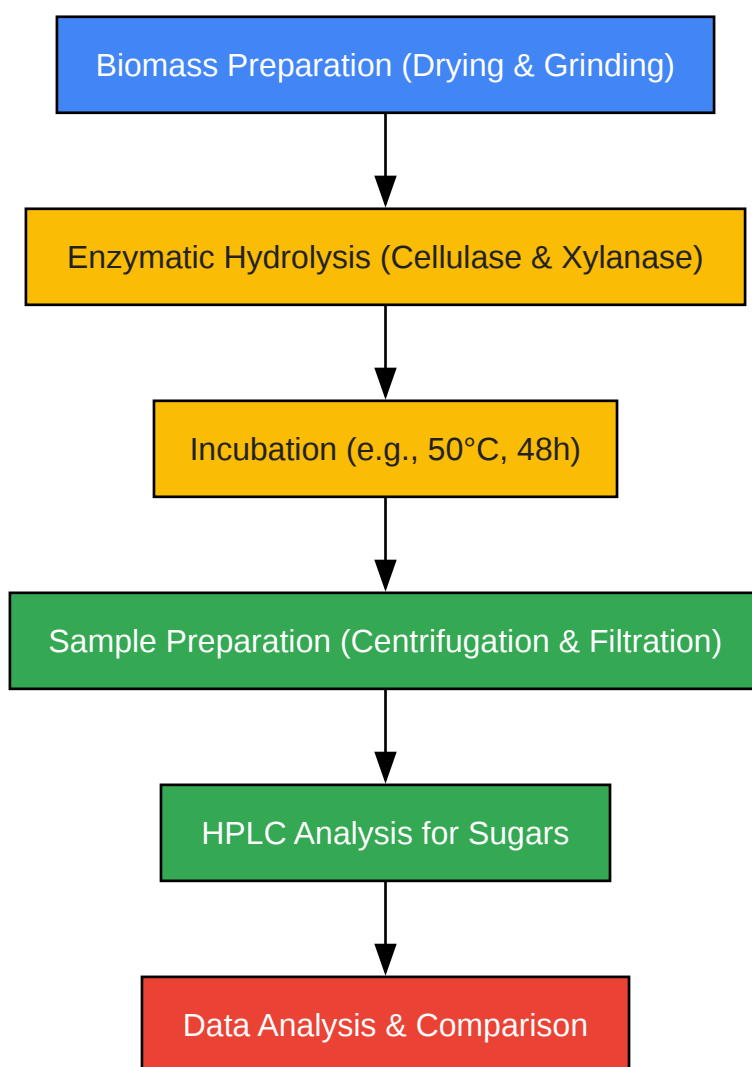

[Click to download full resolution via product page](#)

Caption: Protocol for analyzing enzymatic saccharification efficiency.

## Conclusion

The use of **cef3** mutants represents a promising strategy for improving the efficiency of biofuel production from lignocellulosic feedstocks. By genetically modifying a key component of the secondary cell wall biosynthesis pathway, it is possible to create plants with biomass that is more readily converted into fermentable sugars. The protocols outlined above provide a framework for the generation and analysis of such mutants, paving the way for further research and development in the field of bioenergy.

### Need Custom Synthesis?

BenchChem offers custom synthesis for rare earth carbides and specific isotopic labeling.

Email: [info@benchchem.com](mailto:info@benchchem.com) or [Request Quote Online](#).

## References

- [1. CEF3 is involved in membrane trafficking and essential for secondary cell wall biosynthesis and its mutation enhanced biomass enzymatic saccharification in rice - PMC \[pmc.ncbi.nlm.nih.gov\]](#)
- [2. researchgate.net \[researchgate.net\]](#)
- [3. CEF3 is involved in membrane trafficking and essential for secondary cell wall biosynthesis and its mutation enhanced biomass enzymatic saccharification in rice - PubMed \[pubmed.ncbi.nlm.nih.gov\]](#)
- [4. researchgate.net \[researchgate.net\]](#)
- To cite this document: BenchChem. [Application Notes & Protocols: Leveraging cef3 Mutants for Enhanced Biofuel Production]. BenchChem, [2026]. [Online PDF]. Available at: [\[https://www.benchchem.com/product/b612712/docs#application-notes-protocols-leveraging-cef3-mutants-for-enhanced-biofuel-production\]](https://www.benchchem.com/product/b612712/docs#application-notes-protocols-leveraging-cef3-mutants-for-enhanced-biofuel-production)

---

### Disclaimer & Data Validity:

The information provided in this document is for Research Use Only (RUO) and is strictly not intended for diagnostic or therapeutic procedures. While BenchChem strives to provide accurate protocols, we make no warranties, express or implied, regarding the fitness of this product for every specific experimental setup.

**Technical Support:** The protocols provided are for reference purposes. Unsure if this reagent suits your experiment?

**Need Industrial/Bulk Grade?** [Request Custom Synthesis Quote](#)

## BenchChem

Our mission is to be the trusted global source of essential and advanced chemicals, empowering scientists and researchers to drive progress in science and industry.

### Contact

Address: 3281 E Guasti Rd  
Ontario, CA 91761, United States  
Phone: (601) 213-4426  
Email: [info@benchchem.com](mailto:info@benchchem.com)

[Contact our Ph.D. Support Team for a compatibility check](#)