

# A Comparative Analysis of Seviteronel and Abiraterone on Steroidogenesis

**Author:** BenchChem Technical Support Team. **Date:** December 2025

## Compound of Interest

Compound Name: Seviteronel

Cat. No.: B612235

[Get Quote](#)

For Researchers, Scientists, and Drug Development Professionals

The landscape of therapies for hormone-sensitive cancers, particularly prostate cancer, has been significantly shaped by agents targeting androgen biosynthesis. Abiraterone, a cornerstone in this therapeutic area, and **seviteronel**, a compound with a distinct inhibitory profile, both modulate steroidogenesis but through different mechanisms of action. This guide provides an objective comparison of their effects on steroidogenesis, supported by experimental data, to inform research and drug development endeavors.

## Mechanism of Action: A Tale of Two Inhibitors

Abiraterone acetate is a prodrug of abiraterone, which acts as a potent, irreversible, and non-selective inhibitor of the enzyme 17 $\alpha$ -hydroxylase/17,20-lyase (CYP17A1).[1][2][3] This enzyme is a critical node in the steroidogenesis pathway, catalyzing two key reactions: the 17 $\alpha$ -hydroxylation of pregnenolone and progesterone, and the subsequent 17,20-lyase reaction that converts these hydroxylated products into dehydroepiandrosterone (DHEA) and androstenedione, respectively. By inhibiting both activities, abiraterone effectively shuts down the production of androgens in the testes, adrenal glands, and within the tumor microenvironment.[1]

**Seviteronel**, on the other hand, is a selective inhibitor of the 17,20-lyase activity of CYP17A1.[4][5][6] It exhibits an approximately 10-fold greater selectivity for the 17,20-lyase activity over the 17 $\alpha$ -hydroxylase activity.[4] This selective inhibition is intended to specifically block androgen synthesis while potentially mitigating some of the side effects associated with the

broader inhibition of steroidogenesis seen with non-selective inhibitors. Furthermore, **seviteronel** also functions as a competitive antagonist of the androgen receptor (AR), giving it a dual mechanism of action.[4]

## Impact on Steroidogenesis Pathway

The differential inhibition of CYP17A1 by **seviteronel** and abiraterone leads to distinct alterations in the steroidogenesis cascade. Abiraterone's blockade of both hydroxylase and lyase activities results in a significant reduction of downstream androgens and cortisol. This broad inhibition can lead to a compensatory increase in upstream mineralocorticoids. In contrast, **seviteronel**'s selective inhibition of the 17,20-lyase activity primarily targets the production of androgen precursors, with a lesser impact on cortisol synthesis.

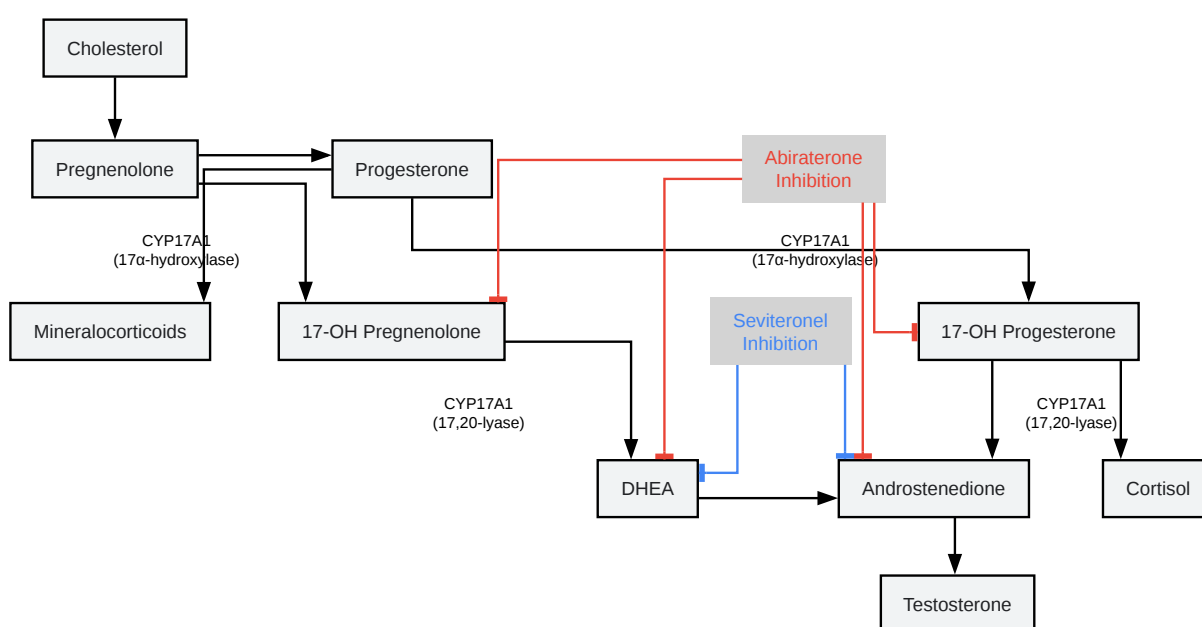

[Click to download full resolution via product page](#)

Steroidogenesis pathway showing inhibition points of Abiraterone and **Seviteronel**.

## Quantitative Comparison of In Vitro Efficacy

The inhibitory potential of abiraterone and the selectivity of **seviteronel** have been characterized in preclinical studies. The following table summarizes the available data on their half-maximal inhibitory concentrations (IC50) against the two activities of CYP17A1.

Compound	CYP17A1 17 $\alpha$ -hydroxylase IC50 (nM)	CYP17A1 17,20-lyase IC50 (nM)	Selectivity (hydroxylase/lyase)
Abiraterone	2.5[1]	15[1]	0.17
Seviteronel	-	-	~10-fold selective for 17,20-lyase[4]

Note: Direct head-to-head IC50 values for **seviteronel** were not available in the reviewed literature.

## Clinical Effects on Steroid Hormone Levels

Clinical trials have provided insights into how the distinct mechanisms of abiraterone and **seviteronel** translate to changes in circulating steroid hormone levels in patients.

Hormone	Seviteronel (NCT02361086) [7]	Abiraterone[8]
Testosterone	18.8% decline from baseline to cycle 2 day 1	90% mean reduction from baseline to week 12
DHEA(S)	12.5% decline in DHEA from baseline to cycle 2 day 1	86% mean reduction in DHEAS from baseline to week 12
Androstenedione	-	92% mean reduction from baseline to week 12
Progesterone	Unchanged from baseline	-
Cortisol	6.4% decline in baseline cortisol at cycle 2 day 1	-

It is important to note that the patient populations, treatment durations, and analytical methods may differ between these studies, warranting caution in direct comparison.

## Experimental Protocols

### In Vitro CYP17A1 Inhibition Assay

A common method to determine the IC50 values for CYP17A1 inhibitors involves a cell-free enzymatic assay.

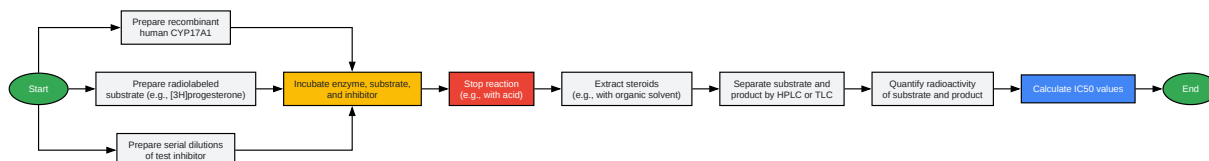

[Click to download full resolution via product page](#)

Workflow for an in vitro CYP17A1 inhibition assay.

Methodology:

- Enzyme Preparation: Recombinant human CYP17A1 is expressed and purified from a suitable system (e.g., E. coli, insect cells).
- Substrate: A radiolabeled steroid substrate, such as [3H]progesterone for the 17 $\alpha$ -hydroxylase activity or [3H]17-hydroxyprogesterone for the 17,20-lyase activity, is used.
- Inhibitor: The test compound (**seviteronel** or abiraterone) is prepared in a series of dilutions.
- Incubation: The enzyme, substrate, and inhibitor are incubated together in a buffer system containing necessary cofactors (e.g., NADPH, cytochrome P450 reductase).
- Reaction Termination: The reaction is stopped at a specific time point, typically by adding a strong acid.
- Extraction and Separation: The steroid products are extracted from the reaction mixture using an organic solvent and then separated from the substrate using high-performance liquid chromatography (HPLC) or thin-layer chromatography (TLC).
- Quantification: The amount of product formed is quantified by measuring its radioactivity.
- IC50 Calculation: The concentration of the inhibitor that causes 50% inhibition of enzyme activity is determined by plotting the percentage of inhibition against the inhibitor concentration.

## Clinical Trial Endocrine Analysis

In clinical studies, the effect of drugs on steroidogenesis is assessed by measuring the levels of various hormones in patient serum or plasma.

Methodology:

- **Sample Collection:** Blood samples are collected from patients at baseline and at specified time points during treatment.[7]
- **Sample Processing:** Serum or plasma is separated from the blood samples.
- **Hormone Measurement:** The concentrations of hormones such as testosterone, DHEA, DHEAS, androstenedione, and cortisol are measured using sensitive and specific analytical methods, most commonly liquid chromatography-tandem mass spectrometry (LC-MS/MS).[7]
- **Data Analysis:** Changes in hormone levels from baseline are calculated and compared between treatment groups or over time.

## Conclusion

**Seviteronel** and abiraterone represent two distinct strategies for targeting the CYP17A1 enzyme in the treatment of hormone-driven cancers. Abiraterone provides a potent and broad inhibition of androgen synthesis by targeting both the 17 $\alpha$ -hydroxylase and 17,20-lyase activities of CYP17A1. This leads to a profound suppression of androgens but can also result in mineralocorticoid excess. **Seviteronel's** selectivity for the 17,20-lyase activity, coupled with its direct AR antagonism, offers a more targeted approach to disrupting androgen signaling. The clinical implications of these different mechanisms, particularly regarding long-term efficacy and safety profiles, continue to be an active area of investigation. This comparative guide provides a foundational understanding of their differential effects on steroidogenesis to aid in the ongoing development of advanced endocrine therapies.

### *Need Custom Synthesis?*

*BenchChem offers custom synthesis for rare earth carbides and specific isotopic labeling.*

*Email: [info@benchchem.com](mailto:info@benchchem.com) or [Request Quote Online](#).*

## References

- 1. researchgate.net [researchgate.net]
- 2. researchgate.net [researchgate.net]

- 3. CYP17 inhibitors--abiraterone, C17,20-lyase inhibitors and multi-targeting agents - PubMed [pubmed.ncbi.nlm.nih.gov]
- 4. Phase 1 Study of Seviteronel, a Selective CYP17 Lyase and Androgen Receptor Inhibitor, in Women with Estrogen Receptor-positive or Triple-negative Breast Cancer - PMC [pmc.ncbi.nlm.nih.gov]
- 5. seviteronel - My Cancer Genome [mycancergenome.org]
- 6. Facebook [cancer.gov]
- 7. aacrjournals.org [aacrjournals.org]
- 8. Androgen dynamics and serum PSA in patients treated with abiraterone acetate - PMC [pmc.ncbi.nlm.nih.gov]
- To cite this document: BenchChem. [A Comparative Analysis of Seviteronel and Abiraterone on Steroidogenesis]. BenchChem, [2025]. [Online PDF]. Available at: [https://www.benchchem.com/product/b612235#comparing-seviteronel-and-abiraterone-s-effect-on-steroidogenesis]

---

#### Disclaimer & Data Validity:

The information provided in this document is for Research Use Only (RUO) and is strictly not intended for diagnostic or therapeutic procedures. While BenchChem strives to provide accurate protocols, we make no warranties, express or implied, regarding the fitness of this product for every specific experimental setup.

**Technical Support:** The protocols provided are for reference purposes. Unsure if this reagent suits your experiment? [[Contact our Ph.D. Support Team for a compatibility check](#)]

**Need Industrial/Bulk Grade?** [Request Custom Synthesis Quote](#)

## BenchChem

Our mission is to be the trusted global source of essential and advanced chemicals, empowering scientists and researchers to drive progress in science and industry.

#### Contact

Address: 3281 E Guasti Rd

Ontario, CA 91761, United States

Phone: (601) 213-4426

Email: [info@benchchem.com](mailto:info@benchchem.com)