

# challenges in working with covalent inhibitors like TED-347

**Author:** BenchChem Technical Support Team. **Date:** December 2025

## Compound of Interest

Compound Name: TED-347

Cat. No.: B611275

[Get Quote](#)

## Technical Support Center: Covalent Inhibitor TED-347

This technical support center provides troubleshooting guidance and frequently asked questions (FAQs) for researchers working with the covalent inhibitor **TED-347**. The information is designed to address common challenges and provide practical solutions for experimental success.

### Troubleshooting Guide

This guide addresses specific issues that may arise during experiments with **TED-347**, offering potential causes and solutions in a question-and-answer format.

Issue ID	Question	Potential Causes	Suggested Solutions
TED347-T01	Why am I observing high variability in my cell viability assay results?	<p>1. Inconsistent inhibitor concentration: Covalent inhibitors' effects are highly dependent on concentration and incubation time. 2. Cell density variation: The Hippo pathway is sensitive to cell density. 3. Incomplete dissolution of TED-347: The compound may precipitate out of solution. 4. Time-dependent effects: As a covalent inhibitor, the duration of exposure is critical.</p>	<p>1. Ensure accurate dilutions: Prepare fresh dilutions for each experiment from a validated stock solution. 2. Maintain consistent cell seeding: Use a precise cell counting method and ensure even cell distribution in plates. 3. Verify solubility: Prepare stock solutions in 100% DMSO and sonicate if necessary. For working solutions, ensure the final DMSO concentration is compatible with your cell line (typically &lt;0.5%). 4. Standardize incubation times: Adhere strictly to the planned incubation times for all experimental replicates.</p>
TED347-T02	My co-immunoprecipitation (Co-IP) experiment to show disruption of the YAP-TEAD interaction is not working.	<p>1. Inefficient lysis: The YAP-TEAD interaction may be disrupted during cell lysis. 2. Insufficient inhibitor treatment: The</p>	<p>1. Use a mild lysis buffer: Employ a non-denaturing lysis buffer to preserve protein-protein interactions. 2. Optimize treatment</p>

concentration or incubation time of TED-347 may not be optimal. 3. Antibody issues: The antibody may not be suitable for IP or may be binding to the epitope involved in the protein-protein interaction. 4. High background: Non-specific binding of proteins to the beads or antibody.

conditions: Perform a dose-response and time-course experiment to determine the optimal conditions for disrupting the YAP-TEAD interaction in your cell line. 3. Validate antibodies: Use IP-validated antibodies and consider using antibodies that target regions of the protein not involved in the interaction. 4. Pre-clear lysate and block beads: Incubate the cell lysate with beads prior to adding the antibody to reduce non-specific binding. Wash the beads extensively.

TED347-T03

I am not seeing a significant decrease in my YAP/TEAD reporter assay signal.

1. Suboptimal transfection efficiency: Low transfection efficiency of the reporter plasmid will result in a weak signal. 2. Inappropriate reporter construct: The reporter may not be sensitive enough to detect changes in

1. Optimize transfection: Use a transfection reagent and protocol optimized for your cell line. 2. Use a validated reporter: Employ a reporter construct with a well-characterized TEAD-responsive element, such as the CTGF

TEAD activity. 3. Cell line is not responsive: The cell line may not have an active Hippo pathway or may be insensitive to YAP/TEAD inhibition. 4. Incorrect timing of treatment: The inhibitor may be added at a suboptimal time point relative to transfection and reporter expression. promoter.[1] 3. Select an appropriate cell line: Use cell lines known to have active Hippo signaling, such as HEK293 or GBM43 cells.[1] 4. Optimize treatment timing: Typically, cells are treated with the inhibitor 24-48 hours after transfection.[1]

TED347-T04

I am concerned about potential off-target effects of TED-347.

1. Reactive warhead: The chloromethyl ketone warhead of TED-347 can react with other nucleophilic residues in the proteome. 2. High inhibitor concentration: Using excessive concentrations of the inhibitor increases the likelihood of off-target binding.

1. Include a non-covalent analog control: Synthesize or obtain a version of TED-347 where the reactive warhead is modified to prevent covalent bond formation. This can help distinguish between effects due to covalent binding and those from non-covalent interactions. 2. Perform dose-response experiments: Use the lowest effective concentration of TED-347 to minimize off-target effects. 3. Conduct proteomic profiling: Use

techniques like  
chemical proteomics  
to identify other  
potential targets of  
TED-347 in an  
unbiased manner.

---

## Frequently Asked Questions (FAQs)

This section provides answers to common questions about the properties and use of **TED-347**.

### 1. What is the mechanism of action of **TED-347**?

**TED-347** is a potent, irreversible, and allosteric covalent inhibitor of the YAP-TEAD protein-protein interaction.[2] It specifically and covalently binds to Cys-367 within the central pocket of TEAD4.[2] This binding event blocks TEAD transcriptional activity, leading to antitumor effects.  
[2]

### 2. What are the recommended storage and handling conditions for **TED-347**?

- Solid form: Store at -20°C for up to 3 years.
- Stock solutions in DMSO: Aliquot and store at -80°C for up to 1 year. Avoid repeated freeze-thaw cycles. For short-term storage, solutions can be kept at -20°C for up to 1 month.[3]

### 3. How should I prepare stock and working solutions of **TED-347**?

- Stock solutions: Prepare a high-concentration stock solution in 100% DMSO. Sonication may be used to aid dissolution.[4]
- Working solutions (in vitro): Dilute the DMSO stock solution in cell culture medium to the desired final concentration. Ensure the final DMSO concentration is not toxic to your cells (typically below 0.5%).
- Working solutions (in vivo): For in vivo experiments, **TED-347** can be formulated in various ways. A common formulation is a suspension in a vehicle like corn oil or a solution containing

DMSO, PEG300, Tween-80, and saline.[2][3] It is recommended to prepare these solutions fresh for each use.

#### 4. What is the difference between IC50, EC50, and Ki for **TED-347**?

- EC50 (Half maximal effective concentration): For **TED-347**, the EC50 is 5.9  $\mu\text{M}$  for the inhibition of the TEAD4-Yap1 protein-protein interaction in a cell-free assay.[3] This value represents the concentration of the inhibitor that gives a half-maximal response.
- Ki (Inhibition constant): The Ki for **TED-347** is 10.3  $\mu\text{M}$  for its covalent interaction with TEAD4.[2] For a covalent inhibitor, the Ki reflects the initial non-covalent binding affinity before the irreversible covalent bond is formed.
- IC50 (Half maximal inhibitory concentration): While often reported, a single IC50 value can be misleading for a covalent inhibitor because its potency is time-dependent. The IC50 will decrease with longer incubation times. It is more informative to determine the kinetic parameters  $k_{\text{inact}}$  and KI to fully characterize the inhibitor's potency.

#### 5. How can I confirm that **TED-347** is covalently binding to TEAD in my experiment?

- Washout experiment: Treat cells with **TED-347**, then wash the cells to remove unbound inhibitor. If the inhibitory effect persists after washout, it suggests covalent and irreversible binding.
- Mass Spectrometry: Intact protein mass spectrometry can be used to detect the mass shift of the TEAD protein after incubation with **TED-347**, confirming the formation of a covalent adduct.
- Competition assay: Pre-incubate your protein of interest with a large excess of a non-covalent binder to the same pocket before adding a tagged version of **TED-347**. A lack of labeling would suggest specific binding.

## Quantitative Data Summary

The following tables summarize key quantitative data for **TED-347** from published studies.

Table 1: In Vitro Potency of **TED-347**

Parameter	Value	Assay Condition	Reference
EC50	5.9 $\mu\text{M}$	Inhibition of TEAD4-Yap1 protein-protein interaction (cell-free)	[3]
Ki	10.3 $\mu\text{M}$	Covalent binding to TEAD4	[2]
Maximum rate of inactivation ( $k_{\text{inact}}$ )	0.038 $\text{h}^{-1}$	[5]	
$t_{1/2\infty}$	18.2 hours	[5]	

Table 2: Cellular Activity of **TED-347**

Cell Line	Assay	Concentration	Incubation Time	Observed Effect	Reference
GBM43	Cell Viability	0.5-100 $\mu$ M	48 hours	Inhibition of cell viability	[2]
HEK-293	Co-IP	5 $\mu$ M	48 hours	Inhibition of Myc-TEAD4 and FLAG-Yap1 co-immunoprecipitation	[2]
GBM43	Gene Expression (CTGF)	10 $\mu$ M	48 hours	Significant reduction in CTGF transcript levels	[2]
Transfected HEK-293	Reporter Assay	0.5-100 $\mu$ M	24 hours	Reduction in TEAD reporter activity	[2]
KYSE-30	Cell Proliferation	10 $\mu$ M	-	Blocked TEAD4-overexpression-induced proliferation	[6]
KYSE-30	Cell Migration & Invasion	10 $\mu$ M	-	Reduced migration and invasion	[6]

## Experimental Protocols

Detailed methodologies for key experiments are provided below.

### Protocol 1: TEAD Reporter Assay



This protocol is adapted from a method used to assess the effect of **TED-347** on TEAD transcriptional activity.[1]

- Cell Seeding: Plate HEK-293 or GBM43 cells at a density of  $2.4 \times 10^4$  cells/well in a 96-well plate.
- Transfection: After 24 hours, transfect the cells with a TEAD-responsive reporter plasmid (e.g., containing the CTGF promoter driving luciferase expression) and a control plasmid for normalization (e.g., TK-Renilla luciferase).
- Inhibitor Treatment: 48 hours post-transfection, treat the cells with various concentrations of **TED-347** (e.g., 0.5, 1.0, 5.0, 10  $\mu$ M) or vehicle control (DMSO).
- Incubation: Incubate the cells for an additional 24-48 hours.
- Luciferase Assay: Measure the luciferase activity according to the manufacturer's instructions for your luciferase assay system.
- Data Analysis: Normalize the TEAD-reporter luciferase signal to the control Renilla luciferase signal.

## Protocol 2: Co-Immunoprecipitation (Co-IP)

This protocol is a general guideline for assessing the disruption of the YAP-TEAD interaction by **TED-347**.

- Cell Culture and Treatment: Culture your chosen cell line (e.g., HEK-293T) and treat with **TED-347** at the desired concentration and for the optimal duration, as determined by preliminary experiments. Include a vehicle-treated control.
- Cell Lysis: Wash the cells with ice-cold PBS and lyse them in a non-denaturing Co-IP lysis buffer containing protease and phosphatase inhibitors.
- Lysate Pre-clearing: Centrifuge the lysates to pellet cell debris. Pre-clear the supernatant by incubating with protein A/G beads for 1 hour at 4°C.
- Immunoprecipitation: Incubate the pre-cleared lysate with an antibody against either YAP or TEAD overnight at 4°C with gentle rotation. A non-specific IgG should be used as a negative

control.

- Immune Complex Capture: Add protein A/G beads to the lysate-antibody mixture and incubate for 2-4 hours at 4°C.
- Washing: Pellet the beads and wash them 3-5 times with Co-IP lysis buffer to remove non-specific binders.
- Elution and Western Blotting: Elute the protein complexes from the beads by boiling in SDS-PAGE sample buffer. Analyze the eluates by Western blotting using antibodies against both YAP and TEAD. A decrease in the co-precipitated protein in the **TED-347**-treated sample compared to the control indicates disruption of the interaction.

## Visualizations

### Hippo Signaling Pathway and TED-347 Mechanism of Action

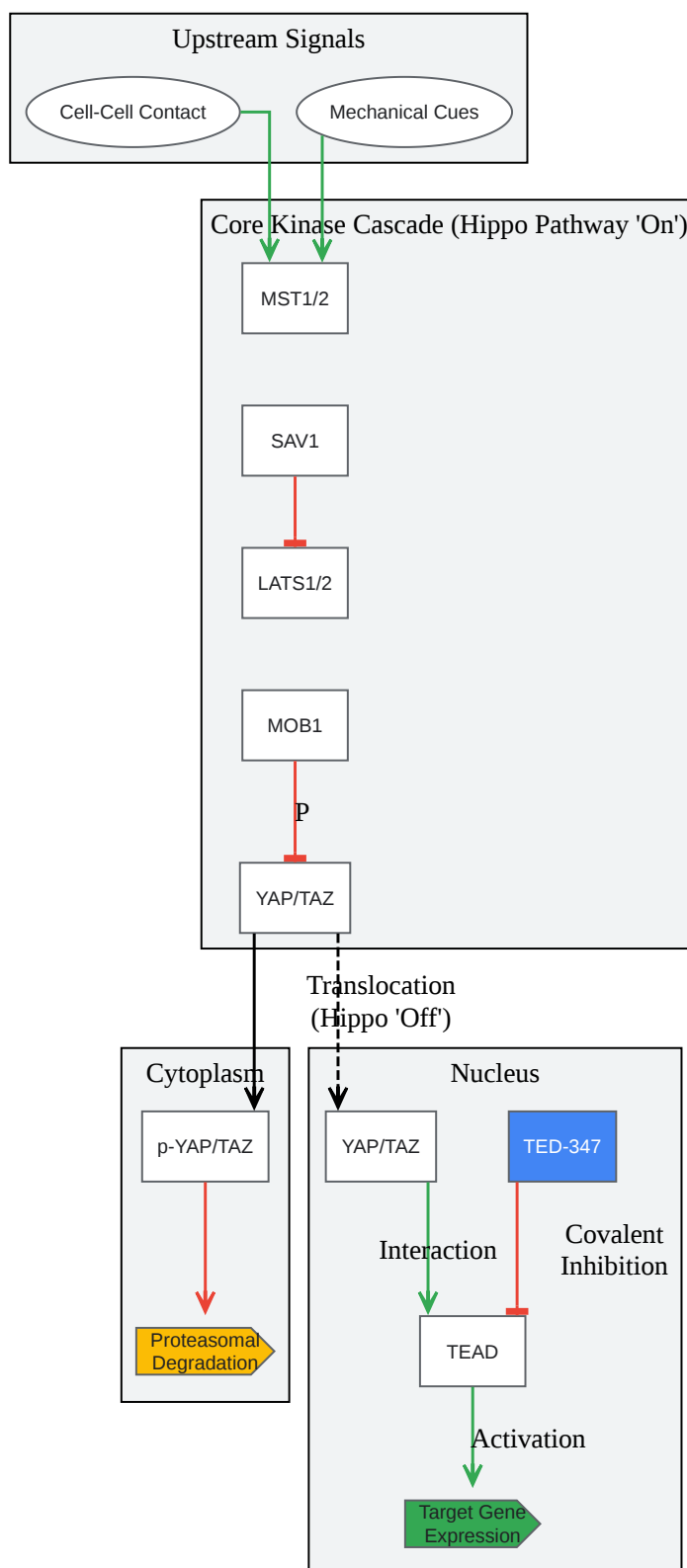

[Click to download full resolution via product page](#)

Caption: Hippo Signaling Pathway and **TED-347** Inhibition.

## Experimental Workflow for Co-Immunoprecipitation

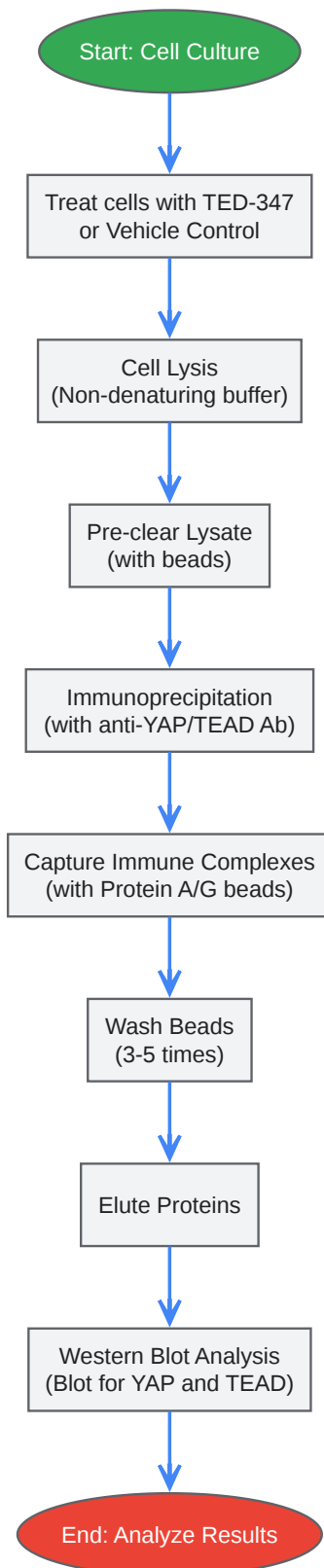

[Click to download full resolution via product page](#)

Caption: Co-Immunoprecipitation Workflow.

## Logical Flow for Troubleshooting a Failed Reporter Assay

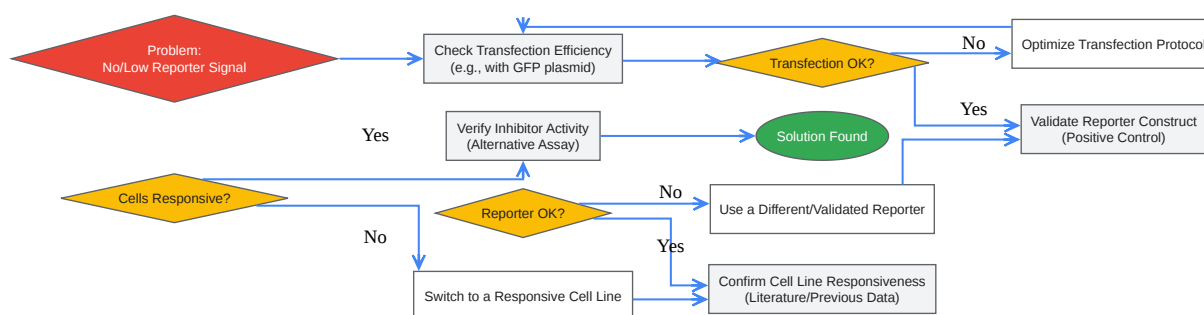

[Click to download full resolution via product page](#)

Caption: Reporter Assay Troubleshooting Flowchart.

### Need Custom Synthesis?

BenchChem offers custom synthesis for rare earth carbides and specific isotopic labeling.

Email: [info@benchchem.com](mailto:info@benchchem.com) or [Request Quote Online](#).

## References

- 1. [selleckchem.com](https://www.selleckchem.com) [selleckchem.com]
- 2. [medchemexpress.com](https://www.medchemexpress.com) [medchemexpress.com]
- 3. [selleckchem.com](https://www.selleckchem.com) [selleckchem.com]
- 4. TED-347 | YAP | TargetMol [targetmol.com]
- 5. [medchemexpress.com](https://www.medchemexpress.com) [medchemexpress.com]

- 6. The interaction of TEA domain transcription factor 4 (TEAD4) and Yes-associated protein 1 (YAP1) promoted the malignant process mediated by serum/glucocorticoid regulated kinase 1 (SGK1) - PMC [pmc.ncbi.nlm.nih.gov]
- To cite this document: BenchChem. [challenges in working with covalent inhibitors like TED-347]. BenchChem, [2025]. [Online PDF]. Available at: [https://www.benchchem.com/product/b611275#challenges-in-working-with-covalent-inhibitors-like-ted-347]

---

### Disclaimer & Data Validity:

The information provided in this document is for Research Use Only (RUO) and is strictly not intended for diagnostic or therapeutic procedures. While BenchChem strives to provide accurate protocols, we make no warranties, express or implied, regarding the fitness of this product for every specific experimental setup.

**Technical Support:** The protocols provided are for reference purposes. Unsure if this reagent suits your experiment? [[Contact our Ph.D. Support Team for a compatibility check](#)]

**Need Industrial/Bulk Grade?** [Request Custom Synthesis Quote](#)

## BenchChem

Our mission is to be the trusted global source of essential and advanced chemicals, empowering scientists and researchers to drive progress in science and industry.

### Contact

Address: 3281 E Guasti Rd  
Ontario, CA 91761, United States  
Phone: (601) 213-4426  
Email: [info@benchchem.com](mailto:info@benchchem.com)