

UAMC-1110 solubility in DMSO and other solvents

Author: BenchChem Technical Support Team. **Date:** December 2025

Compound of Interest

Compound Name: UAMC-1110

Cat. No.: B611531

[Get Quote](#)

Application Notes and Protocols for UAMC-1110

For Researchers, Scientists, and Drug Development Professionals

Introduction

UAMC-1110 is a highly potent and selective small molecule inhibitor of Fibroblast Activation Protein (FAP), a transmembrane serine protease with significant roles in the tumor microenvironment, fibrosis, and inflammation.[1][2] Its restricted expression in healthy tissues and high expression on cancer-associated fibroblasts (CAFs) make FAP an attractive target for therapeutic intervention and diagnostic imaging.[2] **UAMC-1110** serves as a critical research tool for investigating the biological functions of FAP and as a foundational structure for the development of FAP-targeted diagnostics and therapeutics.[3][4] These application notes provide detailed information on the solubility of **UAMC-1110**, along with protocols for its use in common experimental settings.

Physicochemical Properties

Molecular Formula: C₁₇H₁₄F₂N₄O₂ Molecular Weight: 344.3 g/mol CAS Number: 1448440-52-5

Solubility Data

UAMC-1110 exhibits solubility in various common laboratory solvents. Proper dissolution is critical for accurate and reproducible experimental results. The following table summarizes the

known solubility of **UAMC-1110**.

Solvent	Concentration	Notes
DMSO	100 mg/mL (290.43 mM)	Ultrasonic treatment may be required. Use freshly opened, anhydrous DMSO as the compound is hygroscopic.[5]
≥10 mg/mL		
Ethanol	1-10 mg/mL	Sparingly soluble.[6]
Water	Insoluble	A derivative, NH ₂ -UAMC1110 TFA, is soluble in water at 250 mg/mL.[7]

In Vitro Activity

UAMC-1110 is a potent inhibitor of FAP with an IC₅₀ in the low nanomolar range. It also displays selectivity over other related proteases such as prolyl oligopeptidase (PREP).

Target	IC ₅₀	Cell Line/Assay Conditions
FAP	3.2 nM	Recombinant mouse FAP purified from HEK293 cell supernatant, using Ala-Pro-p-nitroanilide as a substrate.[5]
FAP	0.055 μM	Human U87MG cells, using Suc-Gly-Pro-AMC as a substrate.[5]
PREP	1.8 μM	[1][5]

Protocols

Preparation of UAMC-1110 Stock Solutions

This protocol describes the preparation of a concentrated stock solution of **UAMC-1110** in DMSO, which can be further diluted for various in vitro and in vivo applications.

Materials:

- **UAMC-1110** powder
- Anhydrous Dimethyl Sulfoxide (DMSO)
- Sterile microcentrifuge tubes or vials
- Vortex mixer
- Ultrasonic bath (optional)

Procedure:

- Equilibrate the **UAMC-1110** vial to room temperature before opening to prevent moisture condensation.
- Weigh the desired amount of **UAMC-1110** powder in a sterile microcentrifuge tube.
- Add the calculated volume of anhydrous DMSO to achieve the desired concentration (e.g., for a 10 mM stock solution, add 290.43 μ L of DMSO per 1 mg of **UAMC-1110**).
- Vortex the solution thoroughly until the powder is completely dissolved.
- If dissolution is slow, sonicate the solution in an ultrasonic bath for short intervals until the solution is clear.[5]
- Aliquot the stock solution into smaller volumes to avoid repeated freeze-thaw cycles.
- Store the stock solution at -20°C for short-term storage (up to 1 month) or -80°C for long-term storage (up to 6 months).[5]

In Vitro FAP Enzyme Inhibition Assay

This protocol outlines a fluorometric assay to determine the inhibitory activity of **UAMC-1110** against recombinant FAP.

Materials:

- Recombinant human FAP protein
- FAP substrate (e.g., Ala-Pro-AMC)
- Assay buffer (e.g., 50 mM Tris-HCl, pH 7.5, 1 mg/mL BSA)
- **UAMC-1110** stock solution
- 96-well black, flat-bottom plates
- Fluorescence plate reader

Procedure:

- Prepare serial dilutions of **UAMC-1110** in assay buffer.
- In a 96-well plate, add the diluted **UAMC-1110** solutions. Include a vehicle control (DMSO) and a no-enzyme control.
- Add the FAP substrate to all wells at its final working concentration.
- Initiate the reaction by adding recombinant FAP protein to all wells except the no-enzyme control.
- Incubate the plate at 37°C for a specified time (e.g., 30-60 minutes), protected from light.
- Measure the fluorescence intensity using a plate reader with appropriate excitation and emission wavelengths for the chosen substrate (e.g., Ex/Em = 380/460 nm for AMC).
- Calculate the percent inhibition for each **UAMC-1110** concentration relative to the vehicle control and determine the IC₅₀ value by fitting the data to a dose-response curve.

Cell-Based FAP Inhibition Assay

This protocol describes a method to assess the inhibitory effect of **UAMC-1110** on FAP activity in a cellular context using a FAP-expressing cell line.[\[8\]](#)

Materials:

- U87MG cells (or another suitable FAP-expressing cell line)
- Cell culture medium (e.g., DMEM with 10% FBS)
- Phosphate-Buffered Saline (PBS)
- FAP substrate (e.g., Suc-Gly-Pro-AMC)
- **UAMC-1110** stock solution
- 96-well clear-bottom plates
- Fluorescence plate reader

Procedure:

- Seed U87MG cells in a 96-well plate at a density that will result in a confluent monolayer on the day of the assay.
- The following day, remove the culture medium and wash the cells once with PBS.
- Prepare serial dilutions of **UAMC-1110** in PBS.
- Add the diluted **UAMC-1110** solutions to the cells and incubate for a predetermined time (e.g., 30 minutes) at 37°C.
- Add the FAP substrate to each well at its final working concentration.
- Immediately measure the fluorescence intensity over time (kinetic read) or at a fixed endpoint (e.g., 30 minutes) using a fluorescence plate reader.
- Determine the rate of substrate cleavage or the endpoint fluorescence and calculate the IC₅₀ value as described in the enzyme inhibition assay.

In Vivo Formulation for Animal Studies

For in vivo experiments, **UAMC-1110** can be formulated for oral (p.o.) or intravenous (i.v.) administration.[5]

Example Formulation (for p.o. administration): A common formulation involves a mixture of DMSO, PEG300, Tween-80, and saline.[5]

Materials:

- **UAMC-1110**
- DMSO
- PEG300
- Tween-80
- Saline (0.9% NaCl)

Procedure:

- Dissolve **UAMC-1110** in DMSO to create a concentrated stock.
- In a separate tube, mix PEG300 and Tween-80.
- Add the **UAMC-1110**/DMSO stock to the PEG300/Tween-80 mixture and vortex well.
- Slowly add saline to the mixture while vortexing to reach the final desired concentrations (e.g., 10% DMSO, 40% PEG300, 5% Tween-80, 45% Saline).[5]
- Ensure the final solution is clear before administration. Solubility in this vehicle is reported to be at least 2.5 mg/mL.[5]

Signaling Pathways and Visualizations

FAP is known to influence several signaling pathways that are crucial for cancer progression, including the PI3K/Akt and ERK pathways. These pathways are involved in promoting cell proliferation, migration, and angiogenesis.[6][9][10]

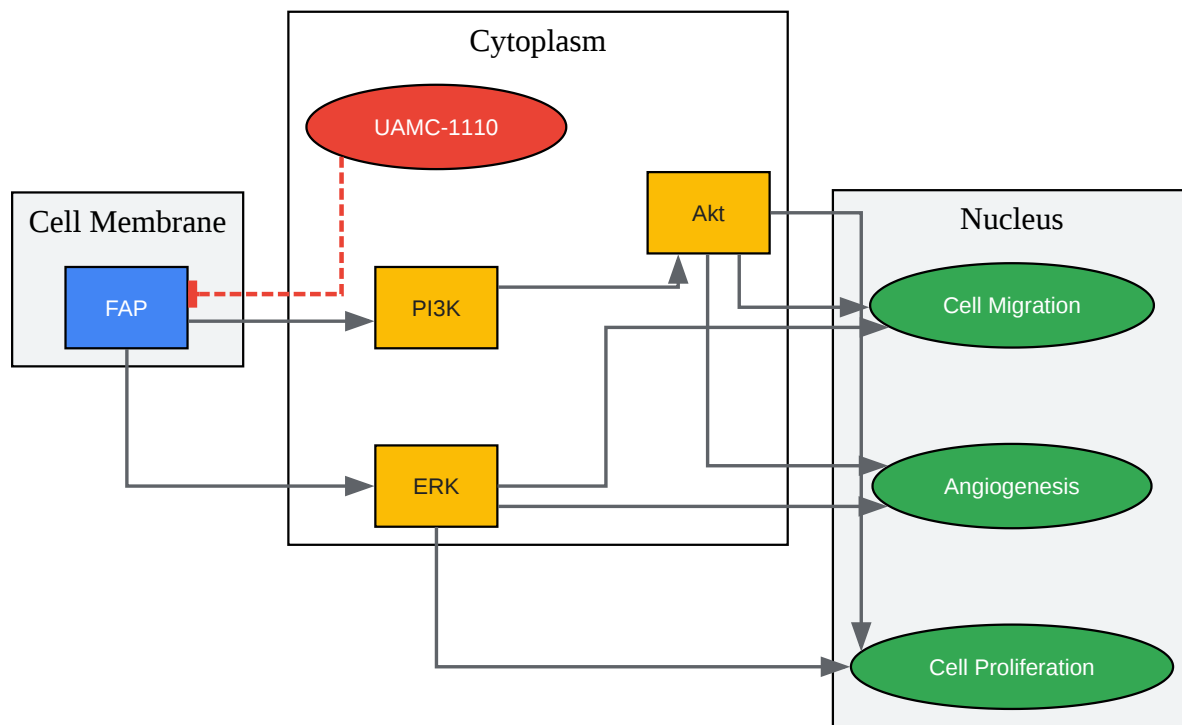

[Click to download full resolution via product page](#)

Caption: FAP signaling pathways and inhibition by **UAMC-1110**.

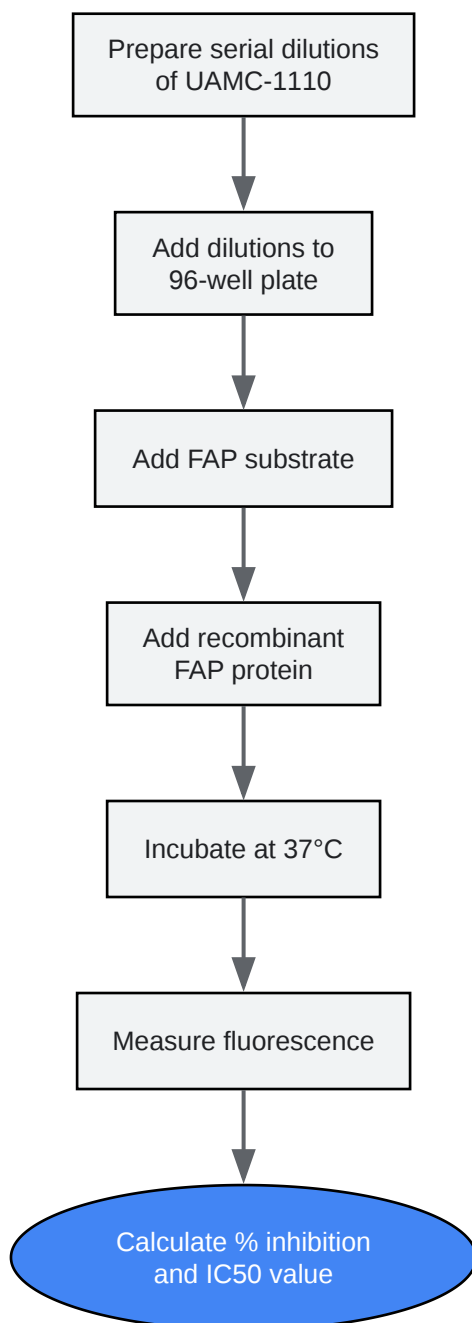

[Click to download full resolution via product page](#)

Need Custom Synthesis?

BenchChem offers custom synthesis for rare earth carbides and specific isotopic labeling.

Email: info@benchchem.com or [Request Quote Online](#).

References

- 1. SP-13786 (UAMC1110, FAP-IN-1) | PREP | CAS 1448440-52-5 | Buy SP-13786 (UAMC1110, FAP-IN-1) from Supplier InvivoChem [invivochem.com]
- 2. Research Portal - Druglike FAPs with maximal target residence time: from chemical discovery to preclinical evaluation in oncology and fibrosis theranostics [research.kuleuven.be]
- 3. [researchgate.net](https://www.researchgate.net) [[researchgate.net](https://www.researchgate.net)]
- 4. [researchgate.net](https://www.researchgate.net) [[researchgate.net](https://www.researchgate.net)]
- 5. [medchemexpress.com](https://www.medchemexpress.com) [[medchemexpress.com](https://www.medchemexpress.com)]
- 6. Fibroblast activation protein- α in tumor cells promotes colorectal cancer angiogenesis via the Akt and ERK signaling pathways - PubMed [pubmed.ncbi.nlm.nih.gov]
- 7. [medchemexpress.com](https://www.medchemexpress.com) [[medchemexpress.com](https://www.medchemexpress.com)]
- 8. A cell-based fluorescent assay for FAP inhibitor discovery - PubMed [pubmed.ncbi.nlm.nih.gov]
- 9. Fibroblast activation protein- α promotes the growth and migration of lung cancer cells via the PI3K and sonic hedgehog pathways - PMC [pmc.ncbi.nlm.nih.gov]
- 10. The role of fibroblast activation protein in health and malignancy - PMC [pmc.ncbi.nlm.nih.gov]
- To cite this document: BenchChem. [UAMC-1110 solubility in DMSO and other solvents]. BenchChem, [2025]. [Online PDF]. Available at: [<https://www.benchchem.com/product/b611531#uamc-1110-solubility-in-dms0-and-other-solvents>]

Disclaimer & Data Validity:

The information provided in this document is for Research Use Only (RUO) and is strictly not intended for diagnostic or therapeutic procedures. While BenchChem strives to provide accurate protocols, we make no warranties, express or implied, regarding the fitness of this product for every specific experimental setup.

Technical Support: The protocols provided are for reference purposes. Unsure if this reagent suits your experiment? [[Contact our Ph.D. Support Team for a compatibility check](#)]

Need Industrial/Bulk Grade? [Request Custom Synthesis Quote](#)

BenchChem

Our mission is to be the trusted global source of essential and advanced chemicals, empowering scientists and researchers to drive progress in science and industry.

Contact

Address: 3281 E Guasti Rd
Ontario, CA 91761, United States
Phone: (601) 213-4426
Email: info@benchchem.com