

Troubleshooting UBP714 solubility and stability issues

Author: BenchChem Technical Support Team. **Date:** April 2026

Compound of Interest

Compound Name: UBP714
CAS No.: 773109-55-0
Cat. No.: B611538

[Get Quote](#)

UBP714 Technical Support Center

This guide provides troubleshooting advice and answers to frequently asked questions regarding the solubility and stability of **UBP714**, a positive allosteric modulator of NMDA receptors.

Frequently Asked Questions (FAQs)

Q1: What is **UBP714** and what is its primary mechanism of action?

UBP714 is a derivative of a coumarin-3-carboxylic acid and functions as a positive allosteric modulator (PAM) of N-methyl-D-aspartate (NMDA) receptors.^{[1][2]} It enhances the activity of NMDA receptors containing various GluN2 subunits (GluN2A, GluN2B, and GluN2D) when activated by agonists like glutamate and a co-agonist such as glycine or D-serine.^{[2][3]} Its primary action is to potentiate the receptor's response, for instance, by enhancing NMDA receptor-mediated excitatory postsynaptic potentials (EPSPs) in hippocampal neurons.^{[1][4]} This makes it a valuable tool for studying synaptic plasticity and its potential therapeutic

applications in conditions linked to NMDA receptor hypofunction, such as schizophrenia.[1][5]
[6]

Q2: What is the recommended solvent for preparing **UBP714** stock solutions?

The recommended solvent for **UBP714** is Dimethyl Sulfoxide (DMSO).[4] It is soluble in DMSO at a concentration of up to 15 mg/mL.[4] For some electrophysiology experiments, researchers have also prepared **UBP714** in an equimolar concentration of NaOH, which can improve its solubility in aqueous solutions.[7]

Q3: How should I store the solid compound and my stock solutions?

Proper storage is critical to maintain the integrity of **UBP714**.

- Solid Compound: Store the lyophilized powder in a dry, dark environment. For short-term storage (days to weeks), 0-4°C is recommended.[1] For long-term storage (months to years), store at -20°C.[1]
- Stock Solutions: Once dissolved in DMSO, aliquot the stock solution into single-use volumes to avoid repeated freeze-thaw cycles. Store these aliquots at -20°C.

Q4: Is **UBP714** stable in aqueous cell culture media?

The stability of **UBP714** in aqueous solutions can be influenced by factors like pH. The mechanism of action for related allosteric modulators has been shown to be pH-sensitive, which may also affect the compound's stability and efficacy over time in buffered solutions like cell culture media.[5] It is recommended to prepare fresh dilutions of the compound from a frozen DMSO stock for each experiment and to add it to the media immediately before use.

Troubleshooting Guide

Issue 1: My **UBP714** powder did not dissolve completely in DMSO.

- Solution: Ensure you are not exceeding the maximum recommended solubility of 15 mg/mL. [4] If you are within this limit, gentle warming (to no more than 37°C) and vortexing can aid dissolution. Ensure the powder is dry before adding the solvent, as absorbed moisture can hinder solubility.

Issue 2: The compound precipitated when I added my DMSO stock to my aqueous buffer or cell culture medium.

This is a common issue when diluting a compound from a high-concentration organic stock into an aqueous solution where its solubility is much lower.

- **Solution 1: Increase Dilution Volume:** Add the DMSO stock to a larger volume of the aqueous buffer while vortexing or stirring vigorously. This helps to disperse the compound quickly and prevent localized high concentrations that lead to precipitation.
- **Solution 2: Use an Intermediate Dilution:** Perform a serial dilution. First, dilute the high-concentration DMSO stock into a smaller volume of your final aqueous buffer. Confirm that it remains in solution before adding this intermediate dilution to the final experimental volume.
- **Solution 3: Incorporate a Surfactant or Carrier:** For certain in vitro experiments, a carrier like 2-(hydroxypropyl)- β -cyclodextrin can be used to improve the solubility of hydrophobic compounds in aqueous solutions.^[7] However, you must first validate that the carrier does not interfere with your experimental model.

Issue 3: I am observing inconsistent results between experiments.

- **Solution 1: Avoid Freeze-Thaw Cycles:** Aliquot your DMSO stock solution into single-use vials after preparation. Repeatedly freezing and thawing a stock solution can lead to compound degradation and moisture absorption, altering the effective concentration.
- **Solution 2: Verify Final Concentration:** Ensure the final concentration of DMSO in your experiment is low (typically <0.5%) and consistent across all conditions, including vehicle controls. High concentrations of DMSO can have independent biological effects.
- **Solution 3: Check pH of Media:** Since the activity of related NMDA receptor modulators can be pH-sensitive, ensure the pH of your experimental buffer or media is stable and consistent.^[5]

Compound Data & Properties

Property	Value	Reference
IUPAC Name	6-Bromo-4-methyl-2-oxo-2H-1-benzopyran-3-carboxylic acid	[1]
CAS Number	773109-55-0	[1][4]
Molecular Formula	C ₁₁ H ₇ BrO ₄	[1]
Molecular Weight	283.07 g/mol	[1][4]
Appearance	White to beige powder	[4]
Purity	≥95% (HPLC)	[4]
Solubility	DMSO: 15 mg/mL	[4]
Storage (Solid)	Short-term: 2-8°C; Long-term: -20°C	[1][4]
Storage (Solution)	-20°C in single-use aliquots	General Lab Practice

Experimental Protocols

Protocol 1: Preparation of a 10 mM **UBP714** Stock Solution in DMSO

- Pre-analysis: Confirm the molecular weight (MW) on the product vial (e.g., 283.08 g/mol).[1]
- Weighing: Accurately weigh out a desired amount of **UBP714** powder (e.g., 1 mg) in a sterile microcentrifuge tube.
- Calculation: Calculate the required volume of DMSO using the formula: $\text{Volume } (\mu\text{L}) = (\text{Weight (mg)} / \text{MW (g/mol)}) * (1,000,000 / \text{Concentration (mM)})$ Example: $(1 \text{ mg} / 283.08 \text{ g/mol}) * (1,000,000 / 10 \text{ mM}) = 353.2 \mu\text{L}$ of DMSO
- Dissolution: Add the calculated volume of high-purity, anhydrous DMSO to the tube.
- Mixing: Vortex the solution thoroughly until all the powder is completely dissolved. Gentle warming to 37°C in a water bath can assist if needed.

- Storage: Aliquot the stock solution into sterile, single-use tubes (e.g., 20 µL per tube) and store at -20°C.

Protocol 2: Preparation of a 100 µM Working Solution for Cell Culture

This protocol is for diluting the 10 mM DMSO stock into a final volume of 2 mL of cell culture medium.

- Thaw Stock: Thaw one aliquot of the 10 mM **UBP714** stock solution at room temperature.
- Calculate Volume: Determine the volume of stock solution needed for a 1:100 dilution to achieve the final concentration of 100 µM. $V_1 = (C_2 * V_2) / C_1$ $V_1 = (100 \mu\text{M} * 2000 \mu\text{L}) / 10,000 \mu\text{M} = 20 \mu\text{L}$
- Pre-warm Medium: Warm the required volume of cell culture medium (2 mL) to 37°C.
- Dilution: Pipette 1980 µL of the pre-warmed medium into a sterile tube. Add the 20 µL of 10 mM **UBP714** stock solution directly into the medium while gently vortexing or flicking the tube to ensure rapid and even dispersion. This minimizes the risk of precipitation. The final DMSO concentration will be 0.1%.
- Vehicle Control: Prepare a vehicle control by adding 20 µL of pure DMSO to 1980 µL of pre-warmed medium.
- Application: Immediately apply the final working solution (and vehicle control) to your cell cultures.

Visualizations

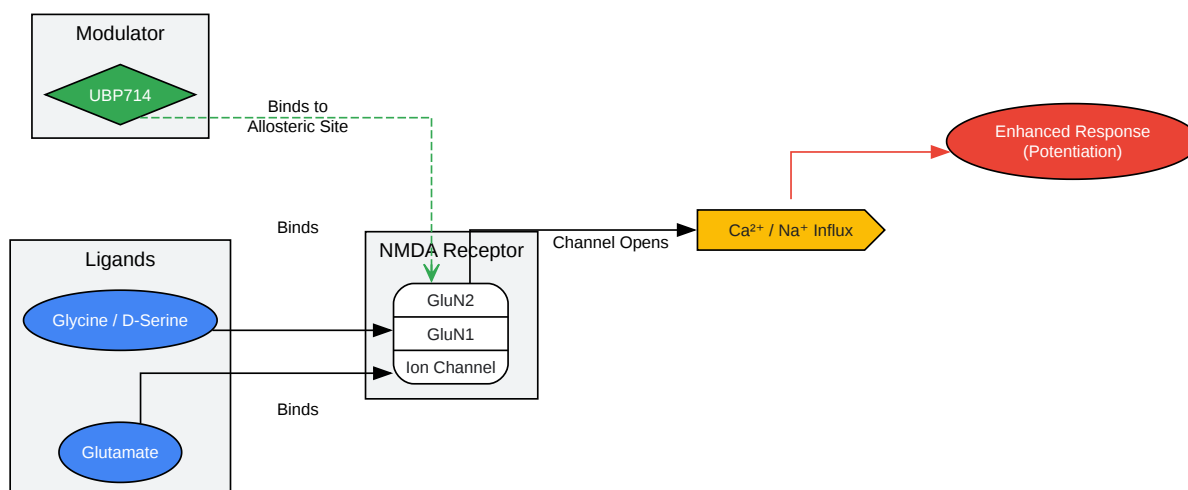

[Click to download full resolution via product page](#)

Caption: Mechanism of **UBP714** as a positive allosteric modulator of the NMDA receptor.

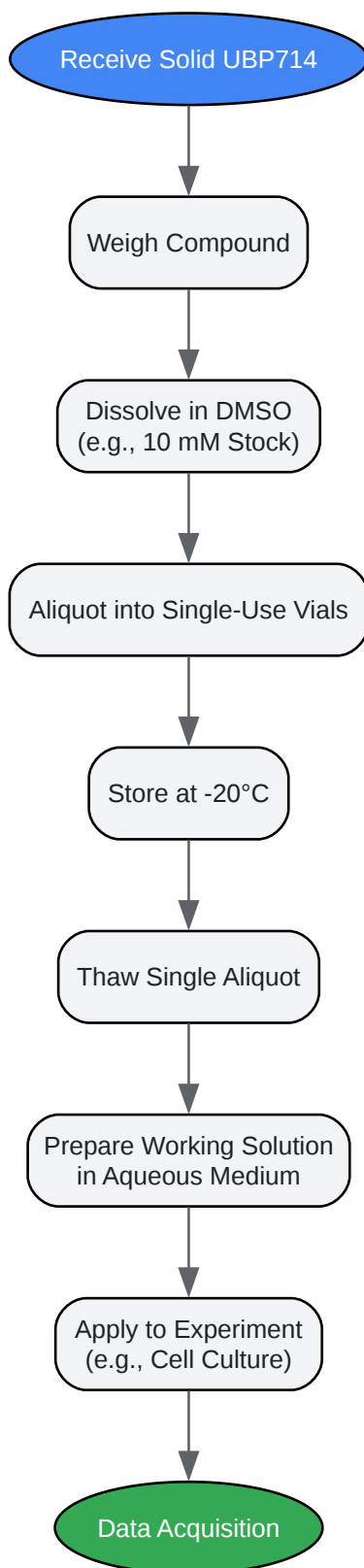

[Click to download full resolution via product page](#)

Caption: Standard experimental workflow for preparing and using **UBP714**.

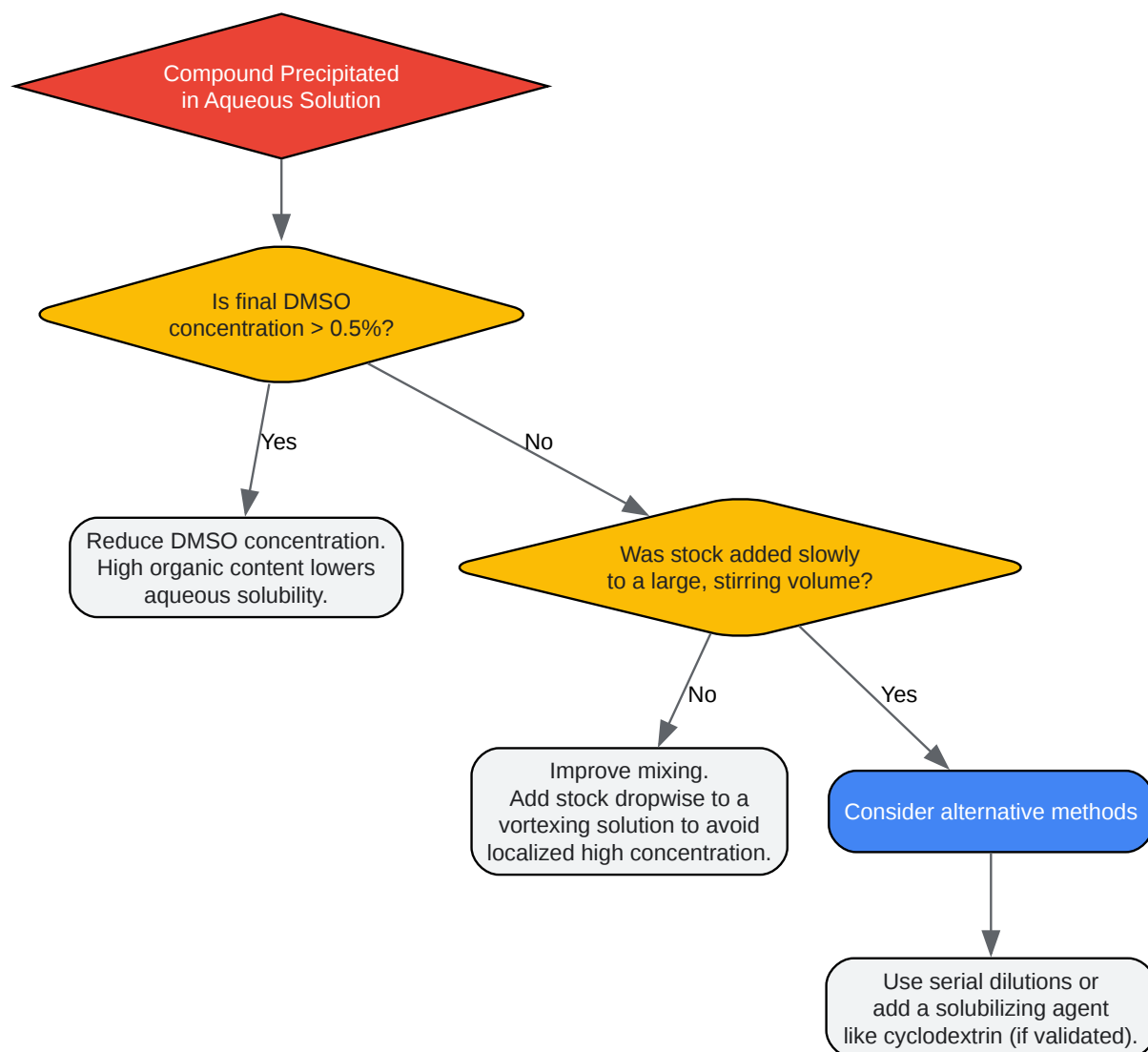

[Click to download full resolution via product page](#)

Caption: Troubleshooting flowchart for **UBP714** precipitation issues.

Need Custom Synthesis?

BenchChem offers custom synthesis for rare earth carbides and specific isotopic labeling.

Email: info@benchchem.com or [Request Quote Online](#).

References

- [1. medkoo.com \[medkoo.com\]](#)
- [2. Enhancing NMDA Receptor Function: Recent Progress on Allosteric Modulators - PMC \[pmc.ncbi.nlm.nih.gov\]](#)
- [3. medchemexpress.com \[medchemexpress.com\]](#)
- [4. UBP714 ≥95% \(HPLC\) | 773109-55-0 \[sigmaaldrich.com\]](#)
- [5. Mechanism and properties of positive allosteric modulation of N-Methyl-D-Aspartate receptors by 6-alkyl 2-naphthoic acid derivatives - PMC \[pmc.ncbi.nlm.nih.gov\]](#)
- [6. A Novel Family of Negative and Positive Allosteric Modulators of NMDA Receptors - PMC \[pmc.ncbi.nlm.nih.gov\]](#)
- [7. Differential regulation of STP, LTP and LTD by structurally diverse NMDA receptor subunit-specific positive allosteric modulators - PMC \[pmc.ncbi.nlm.nih.gov\]](#)
- To cite this document: BenchChem. [Troubleshooting UBP714 solubility and stability issues]. BenchChem, [2026]. [Online PDF]. Available at: [\[https://www.benchchem.com/product/b611538/docs#troubleshooting-ubp714-solubility-and-stability-issues\]](https://www.benchchem.com/product/b611538/docs#troubleshooting-ubp714-solubility-and-stability-issues)

Disclaimer & Data Validity:

The information provided in this document is for Research Use Only (RUO) and is strictly not intended for diagnostic or therapeutic procedures. While BenchChem strives to provide accurate protocols, we make no warranties, express or implied, regarding the fitness of this product for every specific experimental setup.

Technical Support: The protocols provided are for reference purposes. Unsure if this reagent suits your experiment?

Need Industrial/Bulk Grade? [Request Custom Synthesis Quote](#)

BenchChem

Our mission is to be the trusted global source of essential and advanced chemicals, empowering scientists and researchers to drive progress in science and industry.

Contact

Address: 3281 E Guasti Rd

Ontario, CA 91761, United States

Phone: (601) 213-4426

Email: info@benchchem.com

[Contact our Ph.D. Support Team for a compatibility check](#)