

A Comprehensive Technical Guide to the Synthesis of UCM-05194

Author: BenchChem Technical Support Team. **Date:** April 2026

Compound of Interest

Compound Name: UCM-05194

Cat. No.: B611547

[Get Quote](#)

For Researchers, Scientists, and Drug Development Professionals

This technical guide provides an in-depth overview of the synthesis pathway for **UCM-05194**, a potent and selective agonist of the lysophosphatidic acid receptor 1 (LPA1). The information presented is collated from the primary scientific literature, offering a detailed protocol for its chemical preparation. **UCM-05194**, also referred to as (S)-17 in seminal publications, has demonstrated efficacy in the amelioration of neuropathic pain, making its synthesis a topic of significant interest for researchers in pain management and GPCR-targeted drug discovery.[1][2][3]

Chemical Identity and Properties

UCM-05194 is chemically known as (2S)-1-Bromo-3-(phosphonoxy)propan-2-yl 10-phenyldecanoate.[4] Key properties are summarized in the table below.

Identifier	Value
IUPAC Name	(2S)-1-Bromo-3-(phosphonoxy)propan-2-yl 10-phenyldecanoate
CAS Number	2411412-36-5 (S-isomer)[4]
Molecular Formula	C ₁₉ H ₃₀ BrO ₆ P[4]
Molecular Weight	465.32 g/mol [4]
Appearance	Solid[5]

Synthesis Pathway

The synthesis of **UCM-05194** involves a multi-step process, which is detailed in the following sections. The overall synthetic scheme is depicted in the diagram below.

Synthesis Workflow Diagram

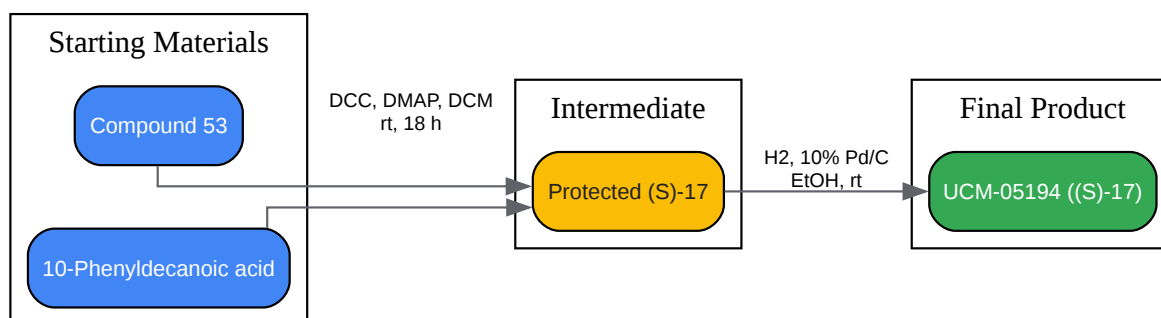

[Click to download full resolution via product page](#)

Caption: Synthesis pathway of **UCM-05194** from starting materials to the final product.

Experimental Protocols

The following protocols are adapted from the peer-reviewed publication by González-Gil et al. in the Journal of Medicinal Chemistry.[1]

Step 1: Synthesis of the Protected Intermediate

This step involves the esterification of a protected glycerol derivative with 10-phenyldecanoic acid.

- Reagents and Materials:
 - Protected glycerol derivative (referred to as compound 53 in the source literature)
 - 10-Phenyldecanoic acid
 - N,N'-Dicyclohexylcarbodiimide (DCC)
 - 4-Dimethylaminopyridine (DMAP)
 - Dichloromethane (DCM)
- Procedure:
 - To a solution of 10-phenyldecanoic acid in dichloromethane (DCM), add the protected glycerol derivative (53), N,N'-dicyclohexylcarbodiimide (DCC), and 4-dimethylaminopyridine (DMAP).
 - The reaction mixture is stirred at room temperature for 18 hours.
 - Upon completion, the reaction is worked up and purified to yield the protected intermediate.
- Yield: 68-73%^[1]

Step 2: Deprotection to Yield UCM-05194 ((S)-17)

The final step is the deprotection of the intermediate to afford the target compound, **UCM-05194**.

- Reagents and Materials:
 - Protected intermediate from Step 1

- 10% Palladium on carbon (Pd/C)
- Ethanol (EtOH)
- Hydrogen gas (H₂)
- Procedure:
 - The protected intermediate is dissolved in ethanol.
 - 10% Palladium on carbon is added to the solution.
 - The mixture is stirred under a hydrogen atmosphere at room temperature.
 - After the reaction is complete, the catalyst is filtered off, and the solvent is removed to yield the final product, **UCM-05194**.
- Yield: 97-99%^[1]

Quantitative Data Summary

The following table summarizes the key quantitative data associated with the synthesis and activity of **UCM-05194**.

Parameter	Value	Reference
Synthesis Yields		
Esterification Step	68-73%	[1]
Deprotection Step	97-99%	[1]
Biological Activity		
LPA1 Receptor Agonism (EC ₅₀)	0.24 μM	[1][5]
LPA1 Receptor Binding Affinity (K _D)	19.6 nM	[1]
Maximal Efficacy (E _{max})	118%	[1]

Signaling Pathway of LPA1 Receptor Activation

UCM-05194 functions as an agonist at the LPA1 receptor, which is a G protein-coupled receptor (GPCR). Activation of LPA1 initiates several downstream signaling cascades.

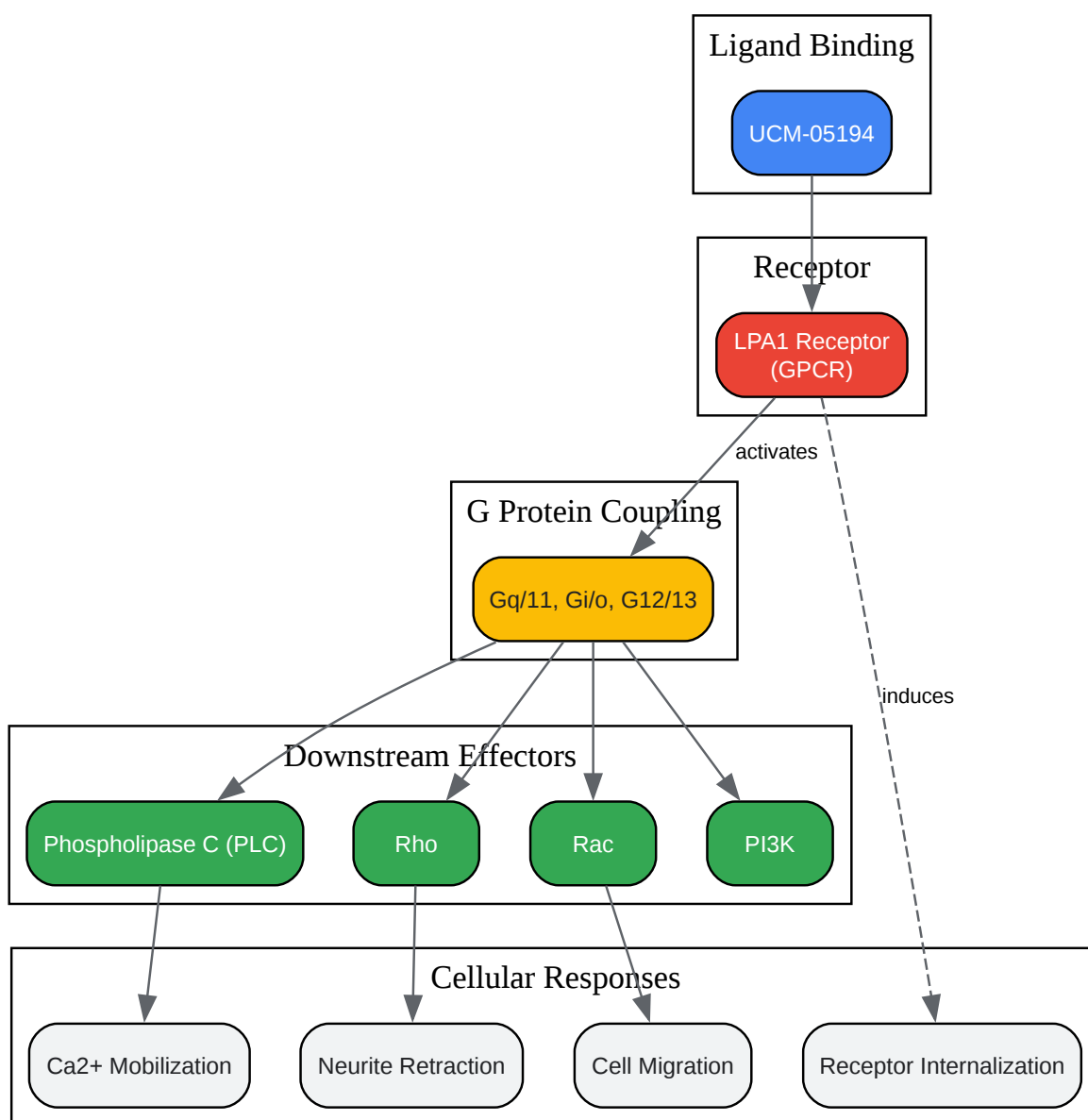

[Click to download full resolution via product page](#)

Caption: Simplified signaling pathway of the LPA1 receptor upon activation by **UCM-05194**.

This guide provides a foundational understanding of the synthesis and mechanism of action of **UCM-05194**. For complete experimental details and characterization data, readers are encouraged to consult the primary literature cited.

Need Custom Synthesis?

BenchChem offers custom synthesis for rare earth carbides and specific isotopic labeling.

Email: info@benchchem.com or [Request Quote Online](#).

References

- [1. A novel agonist of the type 1 lysophosphatidic acid receptor \(LPA1\), UCM-05194, shows efficacy in neuropathic pain amelioration - PMC \[pmc.ncbi.nlm.nih.gov\]](#)
- [2. researchgate.net \[researchgate.net\]](#)
- [3. A Novel Agonist of the Type 1 Lysophosphatidic Acid Receptor \(LPA1\), UCM-05194, Shows Efficacy in Neuropathic Pain Amelioration - PubMed \[pubmed.ncbi.nlm.nih.gov\]](#)
- [4. medkoo.com \[medkoo.com\]](#)
- [5. cdn.caymanchem.com \[cdn.caymanchem.com\]](#)
- To cite this document: BenchChem. [A Comprehensive Technical Guide to the Synthesis of UCM-05194]. BenchChem, [2026]. [Online PDF]. Available at: [\[https://www.benchchem.com/product/b611547/docs#a-comprehensive-technical-guide-to-the-synthesis-of-ucm-05194\]](https://www.benchchem.com/product/b611547/docs#a-comprehensive-technical-guide-to-the-synthesis-of-ucm-05194)

Disclaimer & Data Validity:

The information provided in this document is for Research Use Only (RUO) and is strictly not intended for diagnostic or therapeutic procedures. While BenchChem strives to provide accurate protocols, we make no warranties, express or implied, regarding the fitness of this product for every specific experimental setup.

Technical Support: The protocols provided are for reference purposes. Unsure if this reagent suits your experiment?

Need Industrial/Bulk Grade? [Request Custom Synthesis Quote](#)

BenchChem

Our mission is to be the trusted global source of essential and advanced chemicals, empowering scientists and researchers to drive progress in science and industry.

Contact

Address: 3281 E Guasti Rd

Ontario, CA 91761, United States

Phone: (601) 213-4426

Email: info@benchchem.com

[Contact our Ph.D. Support Team for a compatibility check](#)