

# Technical Guide: The Dual Mechanism of proMMP-9 in Cancer Cell Invasion

**Author:** BenchChem Technical Support Team. **Date:** May 2026

## Compound of Interest

Compound Name: *ProMMP-9 inhibitor-3c*

CAS No.: 2138321-18-1

Cat. No.: B610208

[Get Quote](#)

## Executive Summary

Matrix Metalloproteinase-9 (MMP-9) is frequently cited as a primary driver of extracellular matrix (ECM) remodeling in metastasis.<sup>[1]</sup> However, a common reductionist error in oncology research is viewing proMMP-9 (the 92 kDa zymogen) merely as a latent precursor waiting for activation.

Current data reveals that proMMP-9 possesses distinct biological activity independent of its catalytic cleavage. It acts as a signaling ligand, engaging cell-surface receptors (CD44, Integrins) to drive migration before a single peptide bond is hydrolyzed. This guide dissects the catalytic activation cascade and the non-catalytic signaling axis, providing validated protocols for distinguishing these states in the lab.

## The Biochemistry of Latency: The Cysteine Switch

To target MMP-9 effectively, one must understand the structural lock that maintains its latency. Unlike serine proteases, MMP-9 latency is controlled by the "Cysteine Switch" mechanism.

- Structure: The pro-domain contains a conserved sequence (PRCGVPD).[2] The Cysteine residue (Cys99) within this motif coordinates with the catalytic Zinc ion ( ) in the active site.[3][4]
- Mechanism: This coordination prevents water molecules from attacking the zinc, rendering the enzyme catalytically inert.
- Implication: Activation requires not just cleavage, but the physical disruption of this Cys-Zn interaction. This can occur via proteolysis (canonical) or oxidative stress (ROS modifying Cys99), which is frequent in the hypoxic tumor microenvironment (TME).



*Critical Insight: In Western Blots, proMMP-9 appears at ~92 kDa, while active MMP-9 appears at ~82 kDa.[5] Confusing these bands leads to erroneous conclusions about "MMP activity" when only the zymogen is present.*

---

## Canonical Activation: The Plasmin/MMP-3 Cascade

In the TME, proMMP-9 activation is rarely a single-step event. It is the downstream result of a multi-protease cascade, often initiated by the urokinase plasminogen activator (uPA) system.

### The Activation Logic

- uPA converts Plasminogen to Plasmin.
- Plasmin is a poor activator of proMMP-9 directly but is highly efficient at activating proMMP-3 (Stromelysin-1).[5]
- Active MMP-3 is the potent physiological activator that cleaves the proMMP-9 pro-domain.[5]
- TIMP Regulation: This cascade only proceeds if the molar ratio of MMP-9/MMP-3 exceeds that of Tissue Inhibitors of Metalloproteinases (TIMPs).

## Visualization: The Proteolytic Cascade

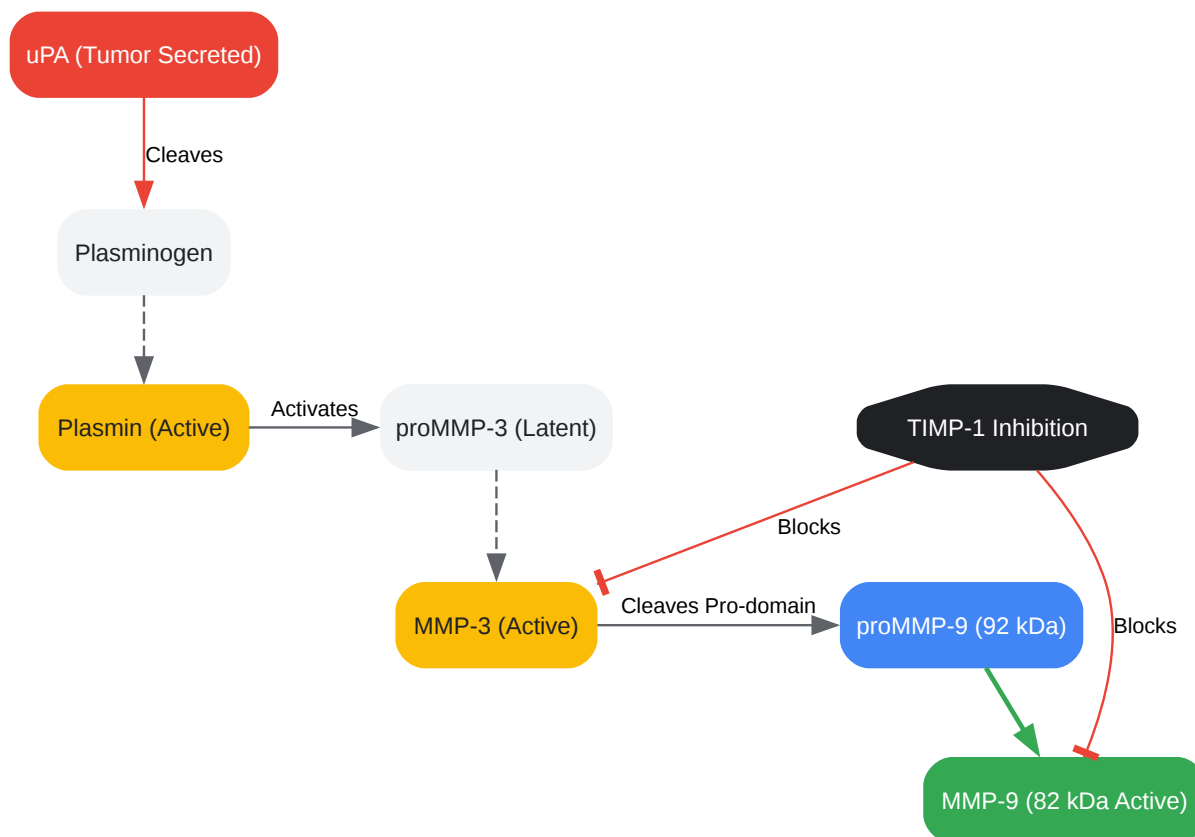

[Click to download full resolution via product page](#)

Figure 1: The stepwise proteolytic cascade required to generate active MMP-9 in the tumor microenvironment.[6]

## Non-Canonical Role: The proMMP-9 Signaling Axis

Recent evidence suggests that proMMP-9 is not biologically inert. It functions as a signaling molecule through its Hemopexin (PEX) domain, driving invasion even in the presence of catalytic inhibitors.

### Mechanism of Action[7][8][9]

- **CD44 Interaction:** The PEX domain of proMMP-9 binds to CD44 on the cell surface. This is critical for docking the protease to the invadopodia.

- EGFR Transactivation: This binding induces EGFR phosphorylation, triggering the MAPK/ERK and PI3K/Akt pathways.
- Result: Enhanced cell migration and survival independent of ECM degradation.
- NGAL Complex: proMMP-9 forms a heterodimer with Neutrophil Gelatinase-Associated Lipocalin (NGAL).[7] NGAL protects proMMP-9 from degradation, effectively increasing the local pool of available zymogen.[8]

## Visualization: Non-Catalytic Signaling

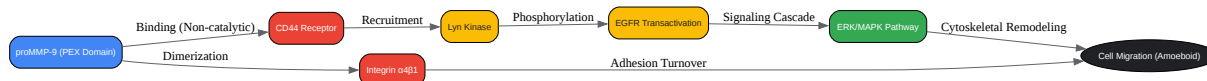

[Click to download full resolution via product page](#)

Figure 2: The non-proteolytic signaling pathway where proMMP-9 acts as a ligand to drive cancer cell migration.

## Experimental Protocols: Validating the Mechanism

To investigate these roles, you must distinguish between the zymogen and the active enzyme. Standard Western Blots are often insufficient due to antibody cross-reactivity. Gelatin Zymography is the gold standard.

### Protocol: Gelatin Zymography for MMP-9

Objective: Quantify proMMP-9 (92 kDa) vs. Active MMP-9 (82 kDa) enzymatic potential.

Step	Parameter	Scientific Rationale
1. Sample Prep	No Reducing Agents (No DTT/BME), No Boiling.	Reducing agents destroy the refolding capacity of the enzyme. Boiling irreversibly denatures it.
2. Gel Casting	10% SDS-PAGE + 1 mg/mL Gelatin.	Gelatin serves as the specific substrate for MMP-2 and MMP-9.[9]
3. Electrophoresis	125V, 4°C.	Cold running prevents premature digestion of the substrate during the run.
4. Renaturation	2.5% Triton X-100 (2x 30 min).	Critical Step: SDS must be removed to allow the enzyme to refold. The "Cysteine Switch" re-opens in the gel.
5. Incubation	50mM Tris, 10mM CaCl <sub>2</sub> , 1μM ZnCl <sub>2</sub> , pH 7.5.	Calcium and Zinc are obligate cofactors. Incubate 16-24h at 37°C.
6. Staining	Coomassie Blue R-250.	Stains the undigested gelatin. MMP activity appears as clear bands against blue background.

## Visualization: Zymography Workflow Logic

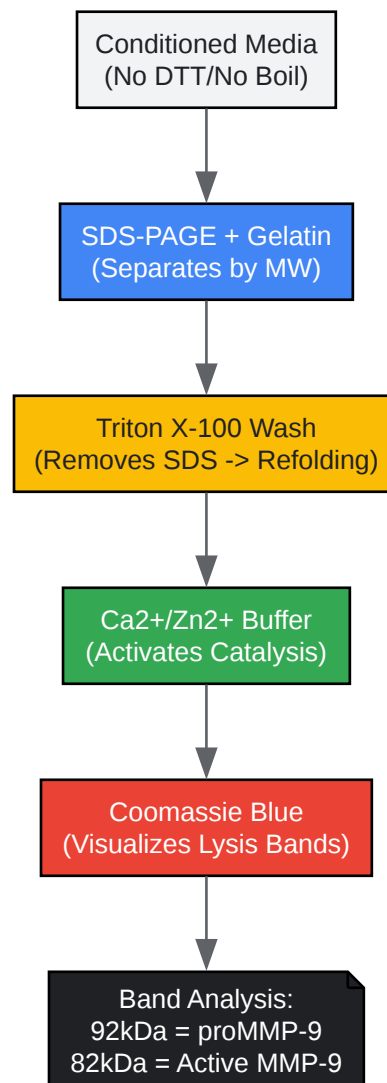

[Click to download full resolution via product page](#)

Figure 3: Logical flow of Gelatin Zymography. Note that proMMP-9 shows activity in zymograms because the SDS-induced denaturation unfolds the pro-domain, detaching the Cysteine switch, which does not re-lock during renaturation.

## Therapeutic Implications

Historical failures of broad-spectrum MMP inhibitors (e.g., Marimostat) stemmed from targeting the catalytic site of all MMPs, causing severe musculoskeletal toxicity (MSS).

Modern Strategy:

- Targeting the PEX Domain: Small molecules or antibodies that bind the Hemopexin domain can block the proMMP-9/CD44 interaction without affecting the catalytic activity of other MMPs. This stops the "signaling-driven" invasion.
- Inhibiting Activation: Antibodies like Andecaliximab (GS-5745) bind proMMP-9 and prevent its cleavage by MMP-3, effectively keeping the "safety pin" (pro-domain) locked.

## References

- MMP-9 Structure & Cysteine Switch: Matrix Metalloproteinase-9 (MMP-9) as a Cancer Biomarker and MMP-9 Biosensors: Recent Advances. (2018).[4][10] National Institutes of Health.
- Activation Cascade: Activation of proMMP-9 by a plasmin/MMP-3 cascade in a tumor cell model. (1999). PubMed.[2]
- CD44 & Non-Catalytic Role: Simultaneous targeting of CD44 and MMP9 catalytic and hemopexin domains as a therapeutic strategy.[11] (2016).[12] PubMed Central.
- NGAL Complex: Neutrophil Gelatinase-Associated Lipocalin (NGAL), Pro-Matrix Metalloproteinase-9 (pro-MMP-9) and Their Complex.[7] (2014).[7][12][13] PubMed Central.
- Zymography Protocol: Gelatin zymography protocol for MMP-9 and MMP-2. Abcam.
- Integrin Interaction: Two distinct integrin binding sites on MMP9 drive cancer invasion. (2024).[13] bioRxiv.

### *Need Custom Synthesis?*

BenchChem offers custom synthesis for rare earth carbides and specific isotopic labeling.

Email: [info@benchchem.com](mailto:info@benchchem.com) or [Request Quote Online](#).

## Sources

- [1. Sequential production and activation of matrix-metalloproteinase-9 \(MMP-9\) with breast cancer progression - PubMed \[pubmed.ncbi.nlm.nih.gov\]](#)

- [2. Matrix Metalloproteinases in Cancer Cell Invasion - Madame Curie Bioscience Database - NCBI Bookshelf \[ncbi.nlm.nih.gov\]](#)
- [3. Novel Matrix Metalloproteinase-9 \(MMP-9\) Inhibitors in Cancer Treatment - PMC \[pmc.ncbi.nlm.nih.gov\]](#)
- [4. Matrix Metalloproteinase-9 \(MMP-9\) as a Cancer Biomarker and MMP-9 Biosensors: Recent Advances - PMC \[pmc.ncbi.nlm.nih.gov\]](#)
- [5. Activation of matrix metalloproteinase-9 \(MMP-9\) via a converging plasmin/stromelysin-1 cascade enhances tumor cell invasion - PubMed \[pubmed.ncbi.nlm.nih.gov\]](#)
- [6. researchgate.net \[researchgate.net\]](#)
- [7. Neutrophil Gelatinase-Associated Lipocalin \(NGAL\), Pro-Matrix Metalloproteinase-9 \(pro-MMP-9\) and Their Complex Pro-MMP-9/NGAL in Leukaemias - PMC \[pmc.ncbi.nlm.nih.gov\]](#)
- [8. Evaluation of neutrophil gelatinase-associated lipocalin \(NGAL\), matrix metalloproteinase-9 \(MMP-9\) and their complex MMP-9/NGAL in sera and urine of patients with kidney tumors - PMC \[pmc.ncbi.nlm.nih.gov\]](#)
- [9. scispace.com \[scispace.com\]](#)
- [10. tandfonline.com \[tandfonline.com\]](#)
- [11. Simultaneous targeting of CD44 and MMP9 catalytic and hemopexin domains as a therapeutic strategy - PMC \[pmc.ncbi.nlm.nih.gov\]](#)
- [12. researchgate.net \[researchgate.net\]](#)
- [13. biorxiv.org \[biorxiv.org\]](#)
- To cite this document: BenchChem. [Technical Guide: The Dual Mechanism of proMMP-9 in Cancer Cell Invasion]. BenchChem, [2026]. [Online PDF]. Available at: [\[https://www.benchchem.com/product/b610208/docs#technical-guide-the-dual-mechanism-of-prommp-9-in-cancer-cell-invasion\]](https://www.benchchem.com/product/b610208/docs#technical-guide-the-dual-mechanism-of-prommp-9-in-cancer-cell-invasion)

---

### Disclaimer & Data Validity:

The information provided in this document is for Research Use Only (RUO) and is strictly not intended for diagnostic or therapeutic procedures. While BenchChem strives to provide accurate protocols, we make no warranties, express or implied, regarding the fitness of this product for every specific experimental setup.

**Technical Support:** The protocols provided are for reference purposes. Unsure if this reagent suits your experiment?

**Need Industrial/Bulk Grade?** [Request Custom Synthesis Quote](#)

## BenchChem

Our mission is to be the trusted global source of essential and advanced chemicals, empowering scientists and researchers to drive progress in science and industry.

### Contact

Address: 3281 E Guasti Rd  
Ontario, CA 91761, United States  
Phone: (601) 213-4426  
Email: [info@benchchem.com](mailto:info@benchchem.com)

[Contact our Ph.D. Support Team for a compatibility check](#)