

Peer-Reviewed Validation of RB-005: A Comparative Guide for Researchers

Author: BenchChem Technical Support Team. **Date:** April 2026

Compound of Interest

Compound Name: RB-005
CAS No.: 1425049-20-2
Cat. No.: B610422

[Get Quote](#)

This guide provides a comparative analysis of the novel Sphingosine Kinase 1 (SK1) inhibitor, **RB-005**, against other known sphingolipid-targeting compounds. The data and methodologies presented are based on peer-reviewed research in the field of colorectal cancer (CRC), offering an objective overview for researchers, scientists, and drug development professionals. A key study highlights that **RB-005** notably inhibits CRC cell growth and proliferation when compared to PF-543 and ABC294640 by inducing a mitochondria-mediated intrinsic apoptotic pathway[1].

Mechanism of Action of RB-005

RB-005 is a selective inhibitor of Sphingosine Kinase 1 (SK1), an enzyme frequently overexpressed in various cancers, including colorectal cancer. SK1 phosphorylates sphingosine to form sphingosine-1-phosphate (S1P), a signaling lipid that promotes cell proliferation, survival, and inflammation while inhibiting apoptosis. By inhibiting SK1, **RB-005** disrupts this pro-survival signaling.

Research indicates a dual, interconnected mechanism for **RB-005**'s anti-cancer effects[2][3]:

- SK1 Inhibition: **RB-005** directly inhibits SK1 activity, leading to decreased intracellular levels of S1P and an accumulation of its pro-apoptotic precursor, ceramide[2].
- PP2A Activation: **RB-005**, a structural analog of the Protein Phosphatase 2A (PP2A) activator FTY720, also promotes the activity of the PP2A tumor suppressor. This activation leads to the dephosphorylation and inactivation of pro-survival proteins such as AKT and ERK[1].

This dual action culminates in the activation of the intrinsic apoptotic pathway, marked by the activation of BAX, release of cytochrome c from the mitochondria, and subsequent caspase activation[2].

Comparative Performance Data

The following tables summarize the comparative efficacy of **RB-005** against alternative sphingosine kinase inhibitors, PF-543 (a potent SK1 inhibitor) and ABC294640 (a selective SK2 inhibitor). The data is based on representative values from studies on colorectal cancer cell lines (HT29 and HCT116).

Table 1: Comparative Cytotoxicity (IC50) in Colorectal Cancer Cell Lines

Compound	Target	HT29 IC50 (µM)	HCT116 IC50 (µM)
RB-005	SK1 (Selective)	~15-20	~10-15
PF-543	SK1 (Potent)	~20-25	~15-20
ABC294640	SK2 (Selective)	> 50	> 50

Note: IC50 values are representative and intended for comparative purposes. Actual values may vary based on specific experimental conditions.

Table 2: Impact on Key Signaling Molecules

Compound (at IC50 conc.)	Effect on S1P Levels	Effect on Ceramide Levels	Effect on PP2A Activity
RB-005	Significantly Decreased	Significantly Increased	Significantly Increased
PF-543	Significantly Decreased	Significantly Increased	No significant change
ABC294640	No significant change	No significant change	No significant change

Signaling Pathway and Experimental Workflow

Signaling Pathway of **RB-005** in Colorectal Cancer Cells

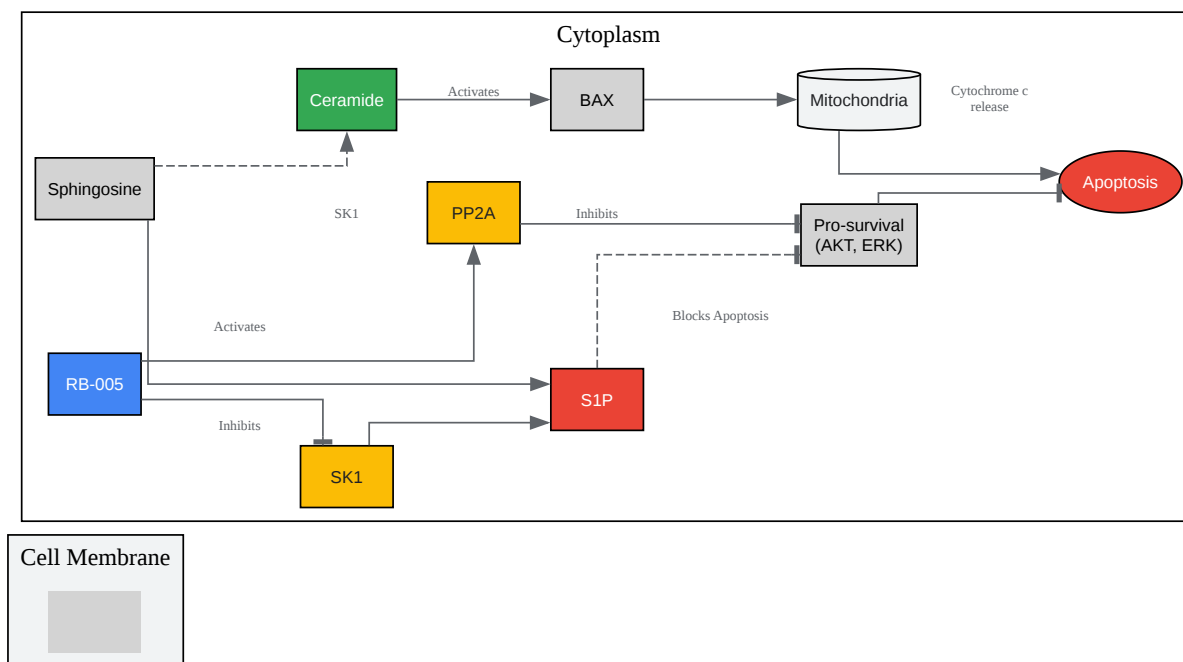

[Click to download full resolution via product page](#)

RB-005 dual-action mechanism inducing apoptosis.

General Experimental Workflow for Inhibitor Comparison

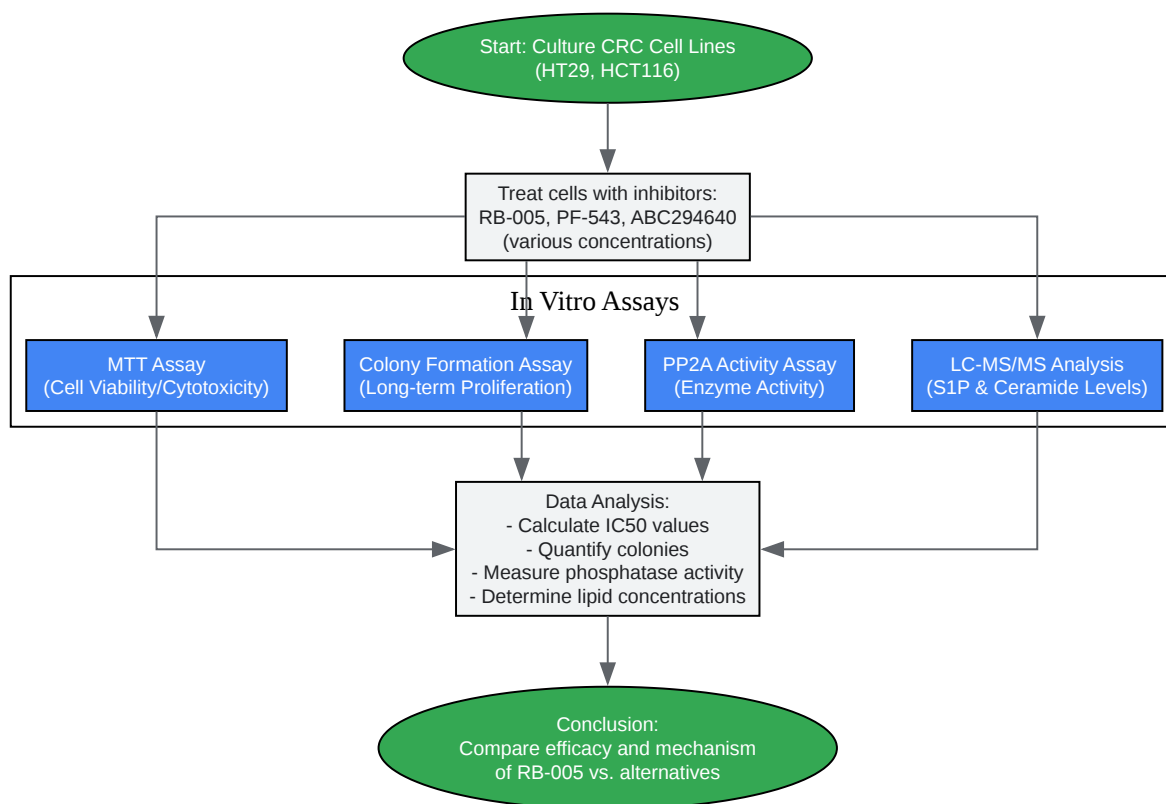

[Click to download full resolution via product page](#)

Workflow for comparing sphingolipid inhibitors.

Experimental Protocols

The following are representative protocols for the key experiments cited in the validation of **RB-005**.

MTT Cell Viability Assay

This assay measures the metabolic activity of cells as an indicator of cell viability.

- **Cell Plating:** Seed colorectal cancer cells (HT29 or HCT116) in a 96-well plate at a density of 5×10^3 cells per well and incubate for 24 hours.
- **Treatment:** Treat the cells with varying concentrations of **RB-005**, PF-543, or ABC294640 for 48-72 hours. Include a vehicle-only control (e.g., DMSO).
- **MTT Addition:** Add 20 μ L of MTT solution (5 mg/mL in PBS) to each well and incubate for 4 hours at 37°C, allowing viable cells to convert MTT to formazan crystals.
- **Solubilization:** Carefully remove the culture medium and add 150 μ L of DMSO to each well to dissolve the formazan crystals.
- **Data Acquisition:** Measure the absorbance at 570 nm using a microplate reader.
- **Analysis:** Calculate the percentage of cell viability relative to the vehicle control and determine the IC₅₀ value for each compound using non-linear regression analysis.

Colony Formation Assay

This assay assesses the long-term proliferative capacity of single cells.

- **Cell Seeding:** Plate a low density of cells (e.g., 500-1000 cells) in 6-well plates.
- **Treatment:** After 24 hours, treat the cells with the respective inhibitors at concentrations below their IC₅₀ values.
- **Incubation:** Incubate the plates for 10-14 days, allowing colonies to form. Replace the medium containing the inhibitors every 3-4 days.
- **Fixing and Staining:** Wash the colonies with PBS, fix with methanol for 15 minutes, and stain with 0.5% crystal violet solution for 20 minutes.
- **Quantification:** Wash the plates with water and air dry. Count the number of colonies (typically >50 cells) in each well.

- Analysis: Compare the number and size of colonies in treated wells to the untreated control to determine the effect on clonogenic survival.

PP2A Activity Assay

This assay quantifies the enzymatic activity of PP2A in cell lysates.

- Cell Lysis: Treat cells with the inhibitors for a specified time (e.g., 24 hours), then harvest and lyse the cells in a suitable lysis buffer containing protease inhibitors.
- Immunoprecipitation: Incubate 50-100 µg of protein lysate with an anti-PP2A antibody overnight at 4°C. Capture the antibody-protein complexes using Protein A/G agarose beads.
- Phosphatase Reaction: Wash the beads and resuspend them in a phosphatase assay buffer. Add a synthetic phosphopeptide substrate (e.g., K-R-pT-I-R-R). Incubate at 30°C for 30 minutes to allow dephosphorylation by active PP2A.
- Phosphate Detection: Terminate the reaction and measure the amount of free phosphate released using a Malachite Green-based detection reagent. Measure absorbance at ~620 nm.
- Analysis: Normalize the PP2A activity to the total amount of immunoprecipitated PP2A protein (quantified by Western Blot) and compare the activity in inhibitor-treated samples to the control.

LC-MS/MS for Sphingolipid Profiling

Liquid chromatography-tandem mass spectrometry is used to quantify intracellular levels of S1P and ceramide.

- Lipid Extraction: After treatment, harvest cells and perform a lipid extraction using a solvent system such as an acidic butanol extraction or a modified Bligh-Dyer method.
- Sample Preparation: Dry the lipid extracts under nitrogen and reconstitute them in a suitable solvent for LC-MS/MS analysis. Include internal standards for quantification.
- Chromatography: Separate the lipid species using a C18 reversed-phase column with a gradient elution of mobile phases (e.g., water/acetonitrile with formic acid).

- **Mass Spectrometry:** Perform mass analysis using a triple-quadrupole mass spectrometer in multiple reaction monitoring (MRM) mode to specifically detect and quantify S1P and various ceramide species.
- **Data Analysis:** Quantify the concentration of each lipid by comparing its peak area to that of the corresponding internal standard. Normalize to total protein or cell number.

Need Custom Synthesis?

BenchChem offers custom synthesis for rare earth carbides and specific isotopic labeling.

Email: info@benchchem.com or [Request Quote Online](#).

References

- [1. researchgate.net \[researchgate.net\]](#)
- [2. Targeting sphingosine 1-phosphate and sphingosine kinases in pancreatic cancer: mechanisms and therapeutic potential - PMC \[pmc.ncbi.nlm.nih.gov\]](#)
- [3. wjgnet.com \[wjgnet.com\]](#)
- To cite this document: BenchChem. [Peer-Reviewed Validation of RB-005: A Comparative Guide for Researchers]. BenchChem, [2026]. [Online PDF]. Available at: [\[https://www.benchchem.com/product/b610422/docs#peer-reviewed-validation-of-rb-005-a-comparative-guide-for-researchers\]](https://www.benchchem.com/product/b610422/docs#peer-reviewed-validation-of-rb-005-a-comparative-guide-for-researchers)

Disclaimer & Data Validity:

The information provided in this document is for Research Use Only (RUO) and is strictly not intended for diagnostic or therapeutic procedures. While BenchChem strives to provide accurate protocols, we make no warranties, express or implied, regarding the fitness of this product for every specific experimental setup.

Technical Support: The protocols provided are for reference purposes. Unsure if this reagent suits your experiment?

Need Industrial/Bulk Grade? [Request Custom Synthesis Quote](#)

BenchChem

Our mission is to be the trusted global source of essential and advanced chemicals, empowering scientists and researchers to drive progress in science and industry.

Contact

Address: 3281 E Guasti Rd

Ontario, CA 91761, United States

Phone: (601) 213-4426

Email: info@benchchem.com

[Contact our Ph.D. Support Team for a compatibility check](#)