

Cellular pathways modulated by PF-739

Author: BenchChem Technical Support Team. **Date:** April 2026

Compound of Interest

Compound Name: PF-739

Cat. No.: B610057

[Get Quote](#)

An In-depth Technical Guide on the Cellular Pathways Modulated by PF-06463922 (Lorlatinib)

For Researchers, Scientists, and Drug Development Professionals

Introduction

PF-06463922, clinically known as Lorlatinib, is a third-generation, ATP-competitive, small-molecule tyrosine kinase inhibitor (TKI).[1] It is a potent, macrocyclic inhibitor of anaplastic lymphoma kinase (ALK) and c-ros oncogene 1 (ROS1).[1][2] A key feature of Lorlatinib is its ability to penetrate the blood-brain barrier, making it an effective treatment for brain metastases, which are common in patients with ALK-positive or ROS1-positive non-small cell lung cancer (NSCLC).[3][4][5] Lorlatinib was specifically designed to be active against most known resistance mutations that can develop during treatment with first and second-generation ALK inhibitors.[1][2]

Mechanism of Action

Lorlatinib functions by binding to the ATP-binding pocket of ALK and ROS1 tyrosine kinases.[3] In many cancers, chromosomal rearrangements lead to the creation of fusion genes (e.g., EML4-ALK, CD74-ROS1) that result in constitutively active kinase domains.[6] This uncontrolled kinase activity drives downstream signaling pathways that promote cell proliferation and survival.[6][7] By inhibiting the kinase activity of ALK and ROS1, Lorlatinib

effectively blocks these oncogenic signals, leading to a reduction in cancer cell proliferation and the induction of apoptosis (programmed cell death).[1][3]

Modulation of Cellular Signaling Pathways

The constitutive activation of ALK and ROS1 fusion proteins leads to the stimulation of several key downstream signaling cascades. Lorlatinib's inhibition of ALK and ROS1 results in the downregulation of these pathways. The primary pathways affected are:

- **RAS-MAPK-ERK Pathway:** This pathway is crucial for cell proliferation.[7] Activated ALK/ROS1 can lead to the phosphorylation of adaptor proteins like SHC and GRB2, which in turn activates RAS and the subsequent MAPK/ERK cascade.[7][8]
- **PI3K-AKT-mTOR Pathway:** This is a critical pathway for promoting cell survival and growth by inhibiting apoptosis.[7][9] ALK/ROS1 can directly or indirectly activate PI3K, leading to the phosphorylation and activation of AKT, which then modulates a variety of downstream targets, including mTOR.[7][8][10]
- **JAK-STAT Pathway:** This pathway is involved in cell proliferation and survival.[7] ALK/ROS1 can phosphorylate and activate STAT3, which then translocates to the nucleus to regulate gene expression.[6][7]
- **PLC γ Pathway:** Activation of Phospholipase C-gamma (PLC γ) by ALK can trigger downstream signaling involving inositol triphosphate (IP3) and diacylglycerol (DAG), which modulate intracellular calcium levels and activate Protein Kinase C (PKC).[7][8]

The diagrams below illustrate the points of inhibition by Lorlatinib within the ALK and ROS1 signaling cascades.

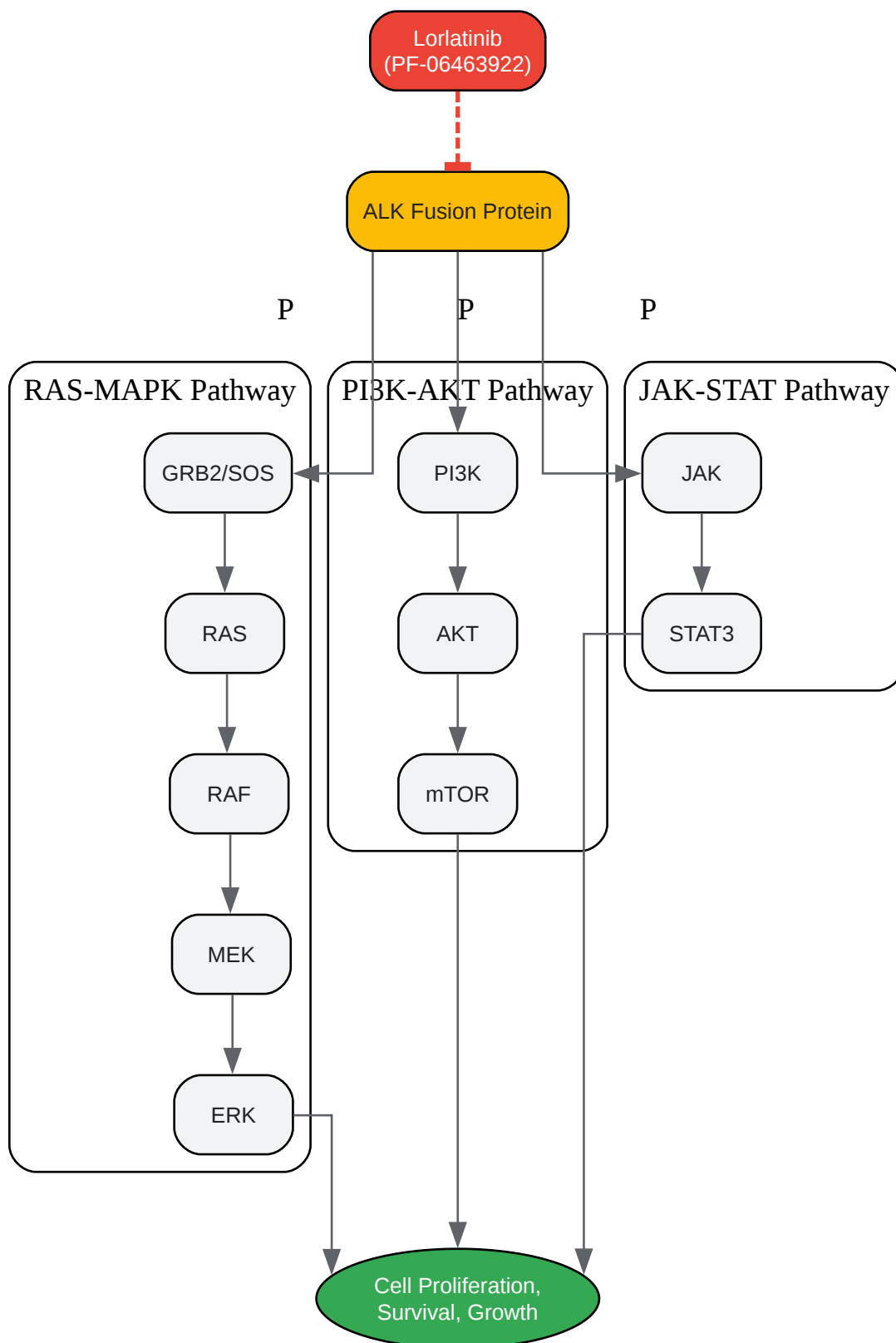

[Click to download full resolution via product page](#)

Caption: ALK Signaling Pathway Inhibition by Lorlatinib.

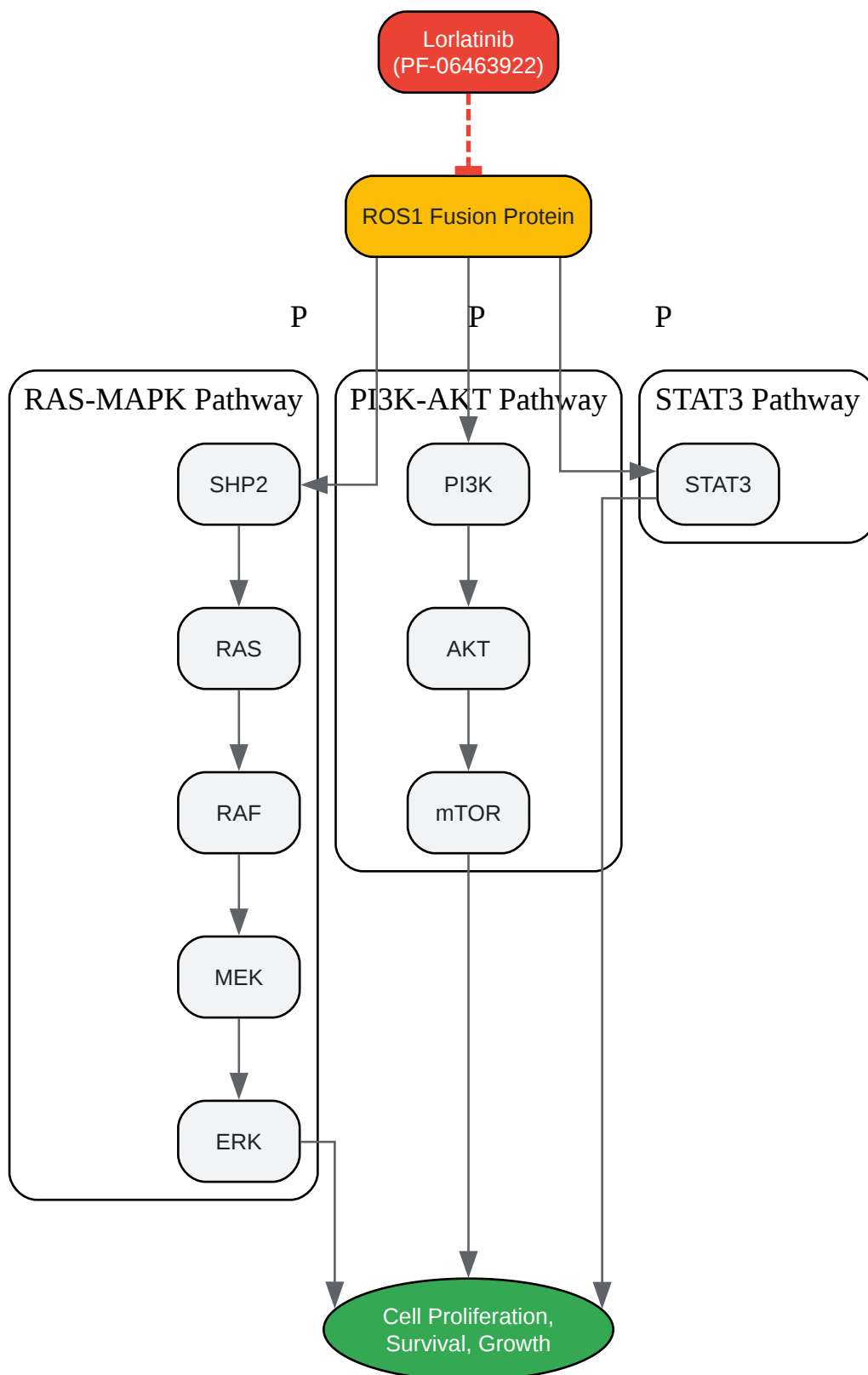

[Click to download full resolution via product page](#)

Caption: ROS1 Signaling Pathway Inhibition by Lorlatinib.

Quantitative Data

Lorlatinib demonstrates potent inhibitory activity against wild-type and mutated ALK and ROS1 kinases. The following tables summarize its in vitro potency.

Table 1: Kinase Inhibitory Potency of Lorlatinib (PF-06463922)

Kinase Target	Ki (nM)	IC50 (nM) - Kinase Activity	Reference
ROS1 (recombinant)	<0.025	-	[11]
ALK (recombinant)	<0.07	-	[11]
ALK (F1174L mutant)	-	~12.7 - 26.6	[12]
ALK (R1275Q mutant)	-	~5.8 - 16.3	[12]
ALK (F1245C mutant)	-	~21.5	[12]

Table 2: Cellular Inhibitory Potency of Lorlatinib (PF-06463922)

Cell Line	Expressed Kinase	IC50 (nM) - Cell Viability	Reference
HCC78	SLC34A2-ROS1	1.3	[11][13]
BaF3	CD74-ROS1	0.6	[11][13]
BaF3	CD74-ROS1 (G2032R mutant)	11.8	[14]
BaF3	CD74-ROS1 (L2026M mutant)	1.9	[14]
NCI-H3122	EML4-ALK	2.8	[12]
NB-1643	ALK (R1275Q mutant)	6.1	[12]
LAN-5	ALK (R1275Q mutant)	16.3	[12]
CLB-GE	ALK (F1174L mutant)	12.7	[12]

Experimental Protocols

Detailed methodologies are crucial for the replication and validation of scientific findings. Below are generalized protocols for key experiments used to characterize the activity of Lorlatinib.

In Vitro Kinase Inhibition Assay

This assay directly measures the ability of a compound to inhibit the enzymatic activity of a purified kinase.

- Objective: To determine the IC₅₀ or K_i value of Lorlatinib against a specific kinase (e.g., ALK, ROS1, and their mutants).
- Methodology:
 - Reagents: Purified recombinant kinase domain, ATP, a substrate peptide (e.g., a generic tyrosine kinase substrate), and Lorlatinib at various concentrations.
 - Procedure: The kinase, substrate, and varying concentrations of Lorlatinib (or DMSO as a control) are incubated in a reaction buffer. The kinase reaction is initiated by the addition of ATP.
 - Detection: The amount of phosphorylated substrate is quantified. This is often done using methods like radiometric assays (measuring incorporation of ³²P-ATP), or more commonly, luminescence-based assays (e.g., ADP-Glo) that measure the amount of ADP produced.
 - Data Analysis: The percentage of kinase inhibition is calculated for each Lorlatinib concentration relative to the DMSO control. The IC₅₀ value is then determined by fitting the data to a dose-response curve.[\[12\]](#)

Cell Viability/Proliferation Assay

This assay measures the effect of a compound on the growth and viability of cancer cell lines.

- Objective: To determine the IC₅₀ of Lorlatinib in cell lines expressing ALK or ROS1 fusion proteins.

- Methodology:
 - Cell Culture: Cancer cell lines (e.g., HCC78, BaF3 expressing a fusion protein) are seeded in 96-well plates and allowed to attach overnight.
 - Treatment: The cells are then treated with a range of concentrations of Lorlatinib (typically a serial dilution) or a vehicle control (DMSO).
 - Incubation: The plates are incubated for a set period (e.g., 72 hours) to allow the compound to exert its effect.
 - Detection: Cell viability is measured using a reagent like CellTiter-Glo® Luminescent Cell Viability Assay, which quantifies ATP levels as an indicator of metabolically active cells.
 - Data Analysis: Luminescence is read on a plate reader. The IC50 value, the concentration at which 50% of cell growth is inhibited, is calculated by plotting the percentage of viable cells against the log of the drug concentration and fitting the data to a sigmoidal dose-response curve.[\[12\]](#)

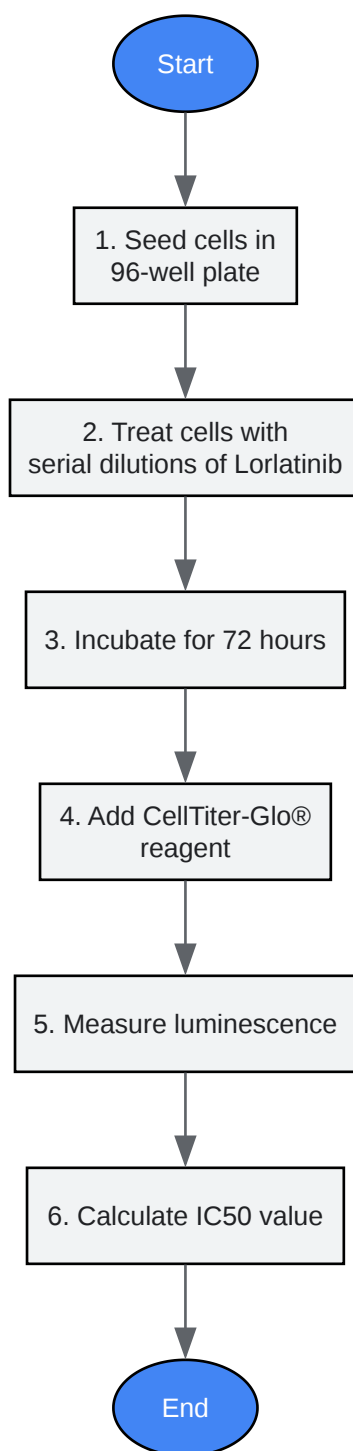

[Click to download full resolution via product page](#)

Caption: Workflow for a Cell Viability Assay.

Western Blotting

This technique is used to detect the levels of specific proteins and their phosphorylation status, providing insight into the activity of signaling pathways.

- Objective: To confirm that Lorlatinib inhibits the phosphorylation of ALK/ROS1 and their downstream signaling proteins (e.g., AKT, ERK, SHP2).
- Methodology:
 - Cell Treatment & Lysis: Cells are treated with Lorlatinib or a vehicle control for a specified time. After treatment, cells are lysed to extract total protein.
 - Protein Quantification: The total protein concentration in each lysate is determined using an assay like the BCA assay.
 - SDS-PAGE: Equal amounts of protein from each sample are separated by size using sodium dodecyl sulfate-polyacrylamide gel electrophoresis (SDS-PAGE).
 - Protein Transfer: The separated proteins are transferred from the gel to a membrane (e.g., PVDF).
 - Immunoblotting: The membrane is blocked and then incubated with primary antibodies specific for the proteins of interest (e.g., anti-phospho-ALK, anti-total-ALK, anti-phospho-ERK, anti-total-ERK).
 - Detection: The membrane is then incubated with a secondary antibody conjugated to an enzyme (like HRP), which catalyzes a chemiluminescent reaction. The signal is captured on X-ray film or with a digital imager.
 - Analysis: The band intensities for phosphorylated proteins are compared between treated and untreated samples, often normalized to the total protein levels, to show a dose-dependent decrease in signaling activity.[\[13\]](#)[\[14\]](#)

Conclusion

PF-06463922 (Lorlatinib) is a highly potent ALK and ROS1 inhibitor that effectively blocks key oncogenic signaling pathways, including the RAS-MAPK, PI3K-AKT, and JAK-STAT pathways. Its ability to overcome a wide range of resistance mutations and penetrate the central nervous

system makes it a critical therapeutic agent in the management of ALK- and ROS1-positive non-small cell lung cancer. The experimental data robustly support its mechanism of action and clinical efficacy.

Need Custom Synthesis?

BenchChem offers custom synthesis for rare earth carbides and specific isotopic labeling.

Email: info@benchchem.com or [Request Quote Online](#).

References

- [1. mdpi.com \[mdpi.com\]](https://www.mdpi.com)
- [2. Pharmacological and clinical properties of lorlatinib in the treatment of ALK-rearranged advanced non-small cell lung cancer - PubMed \[pubmed.ncbi.nlm.nih.gov\]](#)
- [3. What is the mechanism of Lorlatinib? \[synapse.patsnap.com\]](https://synapse.patsnap.com)
- [4. How It Works | Lorbrena® \(lorlatinib\) Patient Site | Safety Info \[lorbrena.com\]](https://lorbrena.com)
- [5. cdn.clinicaltrials.gov \[cdn.clinicaltrials.gov\]](https://cdn.clinicaltrials.gov)
- [6. aacrjournals.org \[aacrjournals.org\]](https://aacrjournals.org)
- [7. creative-diagnostics.com \[creative-diagnostics.com\]](https://creative-diagnostics.com)
- [8. Anaplastic lymphoma kinase: signalling in development and disease - PMC \[pmc.ncbi.nlm.nih.gov\]](#)
- [9. researchgate.net \[researchgate.net\]](https://researchgate.net)
- [10. ROS1 Signaling Pathway Luminex Multiplex Assay - Creative Proteomics \[cytokine.creative-proteomics.com\]](#)
- [11. osti.gov \[osti.gov\]](https://osti.gov)
- [12. The ALK/ROS1 inhibitor PF-06463922 overcomes primary resistance to crizotinib in ALK-driven neuroblastoma - PMC \[pmc.ncbi.nlm.nih.gov\]](#)
- [13. apexbt.com \[apexbt.com\]](https://apexbt.com)
- [14. PF-06463922 is a potent and selective next-generation ROS1/ALK inhibitor capable of blocking crizotinib-resistant ROS1 mutations - PMC \[pmc.ncbi.nlm.nih.gov\]](#)
- To cite this document: BenchChem. [Cellular pathways modulated by PF-739]. BenchChem, [2026]. [Online PDF]. Available at:

[<https://www.benchchem.com/product/b610057/docs#cellular-pathways-modulated-by-pf-739>]

Disclaimer & Data Validity:

The information provided in this document is for Research Use Only (RUO) and is strictly not intended for diagnostic or therapeutic procedures. While BenchChem strives to provide accurate protocols, we make no warranties, express or implied, regarding the fitness of this product for every specific experimental setup.

Technical Support: The protocols provided are for reference purposes. Unsure if this reagent suits your experiment?

Need Industrial/Bulk Grade? [Request Custom Synthesis Quote](#)

BenchChem

Our mission is to be the trusted global source of essential and advanced chemicals, empowering scientists and researchers to drive progress in science and industry.

Contact

Address: 3281 E Guasti Rd
Ontario, CA 91761, United States
Phone: (601) 213-4426
Email: info@benchchem.com

[Contact our Ph.D. Support Team for a compatibility check](#)