

Application Notes: Utilizing RA839 for Anti-Inflammatory Research

Author: BenchChem Technical Support Team. **Date:** April 2026

Compound of Interest

Compound Name: RA839

Cat. No.: B610400

[Get Quote](#)

Introduction

RA839 is a potent and selective small molecule tool compound used to investigate cellular responses to oxidative stress and inflammation.^{[1][2]} It functions as an activator of the Nuclear factor erythroid 2-related factor 2 (Nrf2) signaling pathway.^{[3][4]} **RA839** acts by non-covalently binding to the Kelch-like ECH-associated protein 1 (Keap1), the primary negative regulator of Nrf2.^{[1][2]} This binding disrupts the Keap1-Nrf2 protein-protein interaction, preventing the ubiquitination and subsequent proteasomal degradation of Nrf2.^{[5][6]} The stabilized Nrf2 is then free to translocate to the nucleus, bind to the Antioxidant Response Element (ARE), and initiate the transcription of a suite of cytoprotective and anti-inflammatory genes.^{[1][7]} These application notes provide detailed protocols for using **RA839** to study anti-inflammatory responses in both in vitro and in vivo models.

Mechanism of Action: RA839 and the Nrf2 Pathway

Under basal conditions, Keap1 targets Nrf2 for degradation, keeping its activity low. Upon stimulation by activators like **RA839**, this interaction is inhibited. **RA839** binds to the Kelch domain of Keap1 with a dissociation constant (Kd) of approximately 6 μM .^{[1][2]} This leads to the accumulation of Nrf2, which then drives the expression of genes such as NAD(P)H:quinone

oxidoreductase 1 (NQO1) and heme oxygenase-1 (HO-1). The activation of the Nrf2 pathway can suppress inflammatory responses, in part by inhibiting the expression of pro-inflammatory mediators like inducible nitric oxide synthase (iNOS).[1][7]

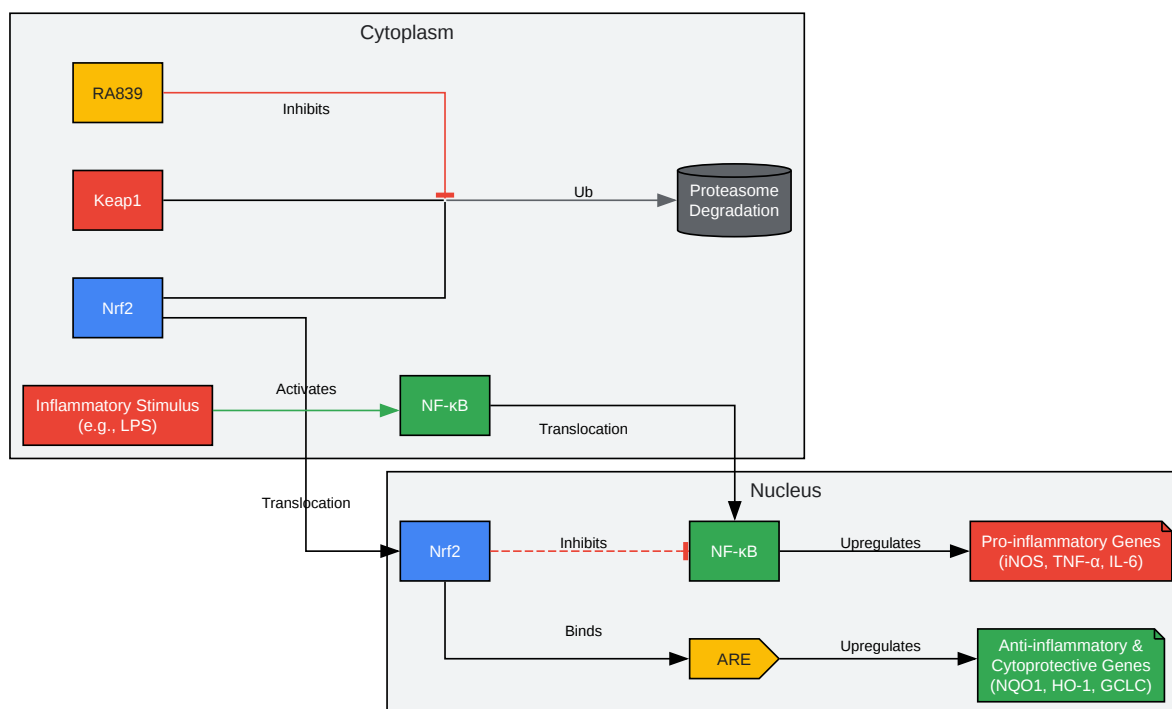

[Click to download full resolution via product page](#)

Caption: Mechanism of **RA839** in modulating inflammatory responses.

Data Presentation: In Vitro and In Vivo Effects of RA839

RA839 has been demonstrated to effectively suppress inflammatory markers in cellular assays and induce Nrf2 target genes in animal models.[1]

Table 1: In Vitro Anti-inflammatory Activity of **RA839** Summary of data from studies on lipopolysaccharide (LPS)-stimulated bone marrow-derived macrophages (BMDMs).

Parameter Measured	Cell Type	Treatment	Concentration of RA839	Result	Reference
Nitric Oxide (NO) Release	BMDM	LPS (100 ng/mL)	5 - 20 μ M	Concentration-dependent reduction in NO release.	[1] [3]
iNOS (Nos2) mRNA Expression	BMDM	LPS (100 ng/mL)	10 μ M	Significant inhibition of LPS-induced iNOS expression.	[1] [1]
NQO1 mRNA Expression	BMDM	LPS (100 ng/mL)	10 μ M	Potent stimulation of the Nrf2 target gene NQO1.	[1]
Cell Viability	BMDM	RA839 alone	Up to 20 μ M	No effect on cell viability.	[1]

Table 2: In Vivo Nrf2 Activation by **RA839** in Mice Summary of data from hepatic tissue of mice 3 hours post-administration.

Gene Measured	Dosing Regimen	Result (Fold Change vs. Vehicle)	Reference
GCLC mRNA	30 mg/kg RA839 (i.p.) + 50 mg/kg ABT	Significant induction.	[1]
NQO1 mRNA	30 mg/kg RA839 (i.p.) + 50 mg/kg ABT	Significant induction.	[1]
Nrf2 mRNA	30 mg/kg RA839 (i.p.) + 50 mg/kg ABT	No significant change.	[1]
Keap1 mRNA	30 mg/kg RA839 (i.p.) + 50 mg/kg ABT	No significant change.	[1]

*Note: Due to rapid metabolism, in vivo studies with **RA839** require co-administration with a cytochrome P450 inhibitor like 1-aminobenzotriazole (ABT) to maintain effective concentrations.[1]

Experimental Protocols

The following protocols provide a framework for studying the anti-inflammatory effects of **RA839**.

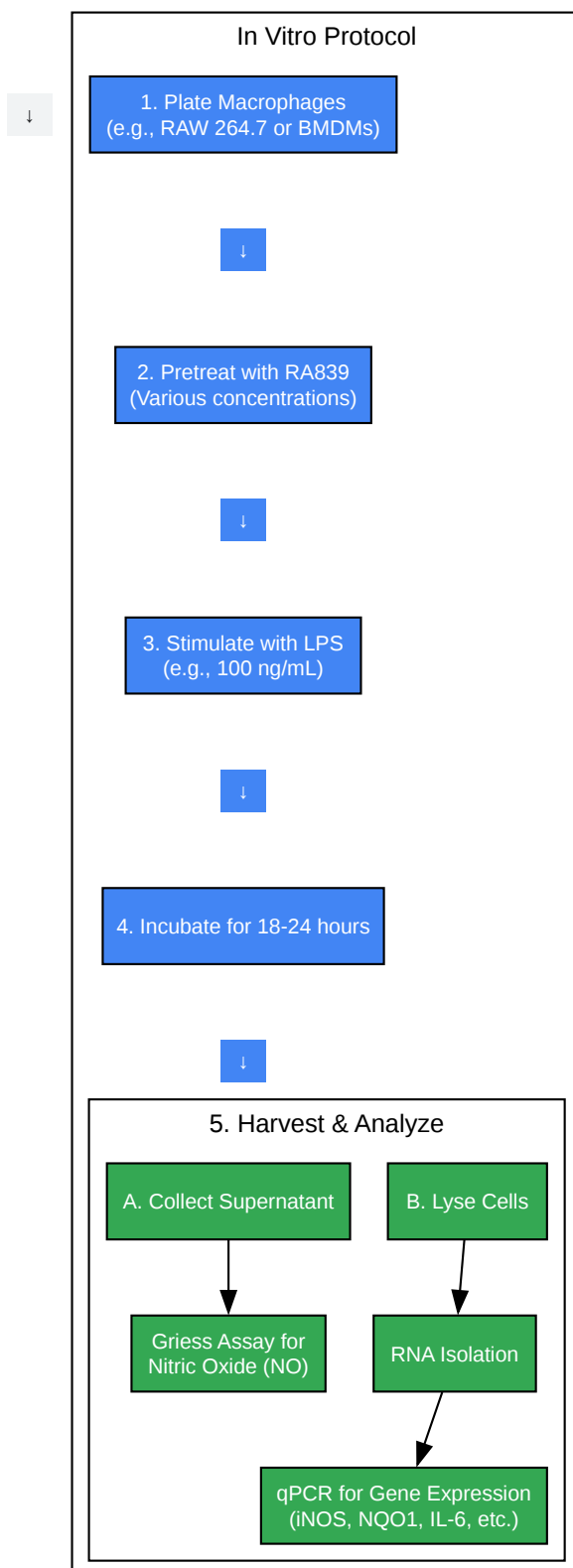

[Click to download full resolution via product page](#)

Caption: General experimental workflow for in vitro analysis of **RA839**.

Protocol 1: In Vitro Inhibition of LPS-Induced Nitric Oxide Production

This protocol details how to measure the effect of **RA839** on nitric oxide (NO) production in macrophages stimulated with LPS.

Materials:

- RAW 264.7 cells or bone marrow-derived macrophages (BMDMs)
- Complete cell culture medium (e.g., DMEM with 10% FBS, 1% Pen/Strep)
- **RA839** (stock solution in DMSO)[4]
- Lipopolysaccharide (LPS) from E. coli
- Griess Reagent System
- 96-well cell culture plates
- Phosphate-Buffered Saline (PBS)

Procedure:

- Cell Plating: Seed macrophages in a 96-well plate at a density of 5×10^4 cells/well and allow them to adhere overnight.
- Pre-treatment: The next day, remove the medium and replace it with fresh medium containing various concentrations of **RA839** (e.g., 1, 5, 10, 20 μM). Include a vehicle control (DMSO) group. Incubate for 2-3 hours.
- Stimulation: Add LPS to the wells to a final concentration of 100 ng/mL. Do not add LPS to the negative control wells.
- Incubation: Incubate the plate for 24 hours at 37°C in a 5% CO₂ incubator.
- NO Measurement: a. After incubation, carefully collect 50 μL of the cell culture supernatant from each well and transfer to a new 96-well plate. b. Perform the Griess assay according to

the manufacturer's instructions to determine the nitrite concentration, which is a stable indicator of NO production. c. Read the absorbance at 540 nm using a microplate reader.

- Data Analysis: Calculate the percentage inhibition of NO production for each **RA839** concentration relative to the LPS-only treated group.

Protocol 2: Analysis of Inflammatory Gene Expression by qPCR

This protocol is for assessing how **RA839** modulates the mRNA expression of pro-inflammatory (e.g., iNOS, IL-6, TNF- α) and Nrf2 target (e.g., NQO1, GCLC) genes.

Materials:

- Cells treated as described in Protocol 1 (steps 1-4, typically in 6-well plates)
- RNA lysis buffer (e.g., TRIzol)
- RNA isolation kit
- cDNA synthesis kit
- qPCR master mix (e.g., SYBR Green)
- Gene-specific primers (for iNOS, NQO1, and a housekeeping gene like GAPDH)

Procedure:

- Cell Lysis: After the 24-hour incubation period, remove the supernatant and wash the cells with cold PBS. Add 1 mL of RNA lysis buffer to each well and scrape the cells.
- RNA Isolation: Purify total RNA from the cell lysates using an RNA isolation kit according to the manufacturer's protocol. Quantify the RNA and assess its purity.
- cDNA Synthesis: Reverse transcribe 1 μ g of total RNA into cDNA using a cDNA synthesis kit.
- qPCR: a. Prepare the qPCR reaction mixture containing qPCR master mix, forward and reverse primers for the gene of interest, and the synthesized cDNA. b. Run the qPCR

reaction on a real-time PCR system.

- Data Analysis: Calculate the relative gene expression using the $\Delta\Delta C_t$ method, normalizing the expression of target genes to the housekeeping gene. Compare the expression levels in **RA839**-treated groups to the LPS-only control.

Protocol 3: In Vivo Activation of Nrf2 Target Genes in Mice

This protocol describes an acute in vivo experiment to confirm that **RA839** can activate the Nrf2 pathway in a living organism.

Materials:

- C57BL/6 mice (8-10 weeks old)
- **RA839**
- 1-aminobenzotriazole (ABT)
- Vehicle solution (e.g., 0.5% (w/v) hydroxyethyl cellulose with 5% (v/v) Solutol)[1]
- Saline
- RNA isolation reagents and qPCR materials (as in Protocol 2)

Procedure:

- Animal Acclimation: Acclimate mice to the facility for at least one week before the experiment.
- ABT Administration: One hour prior to **RA839** administration, administer ABT (50 mg/kg) via oral gavage to inhibit cytochrome P450-mediated metabolism.[1]
- **RA839** Administration: Administer **RA839** (30 mg/kg) or vehicle via intraperitoneal (i.p.) injection.[1][3]

- Tissue Collection: Three hours after **RA839** administration, euthanize the mice.[1] Immediately perfuse the animals with cold PBS and harvest the liver. Snap-freeze the tissue in liquid nitrogen and store at -80°C.
- Gene Expression Analysis: Homogenize the liver tissue and perform RNA isolation, cDNA synthesis, and qPCR as described in Protocol 2 to measure the expression of Nrf2 target genes (e.g., GCLC, NQO1).
- Data Analysis: Compare the relative gene expression in the **RA839**-treated group to the vehicle-treated group to determine the fold induction of Nrf2 target genes.

Need Custom Synthesis?

BenchChem offers custom synthesis for rare earth carbides and specific isotopic labeling.

Email: info@benchchem.com or [Request Quote Online](#).

References

- 1. Characterization of RA839, a Noncovalent Small Molecule Binder to Keap1 and Selective Activator of Nrf2 Signaling - PMC [[pmc.ncbi.nlm.nih.gov](https://pubmed.ncbi.nlm.nih.gov/31111111/)]
- 2. Characterization of RA839, a Noncovalent Small Molecule Binder to Keap1 and Selective Activator of Nrf2 Signaling - PubMed [[pubmed.ncbi.nlm.nih.gov](https://pubmed.ncbi.nlm.nih.gov/31111111/)]
- 3. [medchemexpress.com](https://www.medchemexpress.com/) [[medchemexpress.com](https://www.medchemexpress.com/)]
- 4. [rndsystems.com](https://www.rndsystems.com/) [[rndsystems.com](https://www.rndsystems.com/)]
- 5. Small molecules inhibiting Keap1–Nrf2 protein–protein interactions: a novel approach to activate Nrf2 function - PMC [[pmc.ncbi.nlm.nih.gov](https://pubmed.ncbi.nlm.nih.gov/31111111/)]
- 6. Nrf2 activation through the inhibition of Keap1-Nrf2 protein-protein interaction - PMC [[pmc.ncbi.nlm.nih.gov](https://pubmed.ncbi.nlm.nih.gov/31111111/)]
- 7. [mdpi.com](https://www.mdpi.com/) [[mdpi.com](https://www.mdpi.com/)]
- To cite this document: BenchChem. [Application Notes: Utilizing RA839 for Anti-Inflammatory Research]. BenchChem, [2026]. [Online PDF]. Available at: [<https://www.benchchem.com/product/b610400/docs#application-notes-utilizing-ra839-for-anti-inflammatory-research>]

Disclaimer & Data Validity:

The information provided in this document is for Research Use Only (RUO) and is strictly not intended for diagnostic or therapeutic procedures. While BenchChem strives to provide accurate protocols, we make no warranties, express or implied, regarding the fitness of this product for every specific experimental setup.

Technical Support: The protocols provided are for reference purposes. Unsure if this reagent suits your experiment?

Need Industrial/Bulk Grade? [Request Custom Synthesis Quote](#)

BenchChem

Our mission is to be the trusted global source of essential and advanced chemicals, empowering scientists and researchers to drive progress in science and industry.

Contact

Address: 3281 E Guasti Rd
Ontario, CA 91761, United States
Phone: (601) 213-4426
Email: info@benchchem.com

[Contact our Ph.D. Support Team for a compatibility check](#)