

Application Note & Protocol: In Vitro Assays to Measure PQBP1 Binding Activity

Author: BenchChem Technical Support Team. **Date:** December 2025

Compound of Interest

Compound Name: PQ1

Cat. No.: B610178

[Get Quote](#)

Audience: Researchers, scientists, and drug development professionals.

Introduction:

Polyglutamine-binding protein 1 (PQBP1) is a multifaceted nuclear protein implicated in a range of cellular processes, including transcription, pre-mRNA splicing, and innate immunity.[1][2] Its dysfunction is linked to neurodevelopmental disorders such as Renpenning syndrome, as well as neurodegenerative diseases like Huntington's and Alzheimer's disease.[1][3] PQBP1's ability to interact with a diverse set of molecules, including proteins with expanded polyglutamine tracts, splicing factors, and viral DNA, underscores its importance as a potential therapeutic target.[2][3][4] This application note provides detailed protocols for in vitro assays designed to measure the binding activity of PQBP1 with its interaction partners, offering valuable tools for basic research and drug discovery.

Signaling and Interaction Pathways Involving PQBP1

PQBP1's interactions are central to its function. In the nucleus, it plays a crucial role in gene expression by interacting with components of the transcription and splicing machinery.[1][5] A key interaction is with the splicing factor TXNL4A, which PQBP1 helps import into the nucleus.[6] In the cytoplasm, PQBP1 acts as a sensor for viral DNA. Upon HIV-1 infection, PQBP1 binds to reverse-transcribed viral DNA and interacts with cyclic GMP-AMP synthase (cGAS) to initiate the cGAS-STING innate immune signaling pathway.[4][5][7]

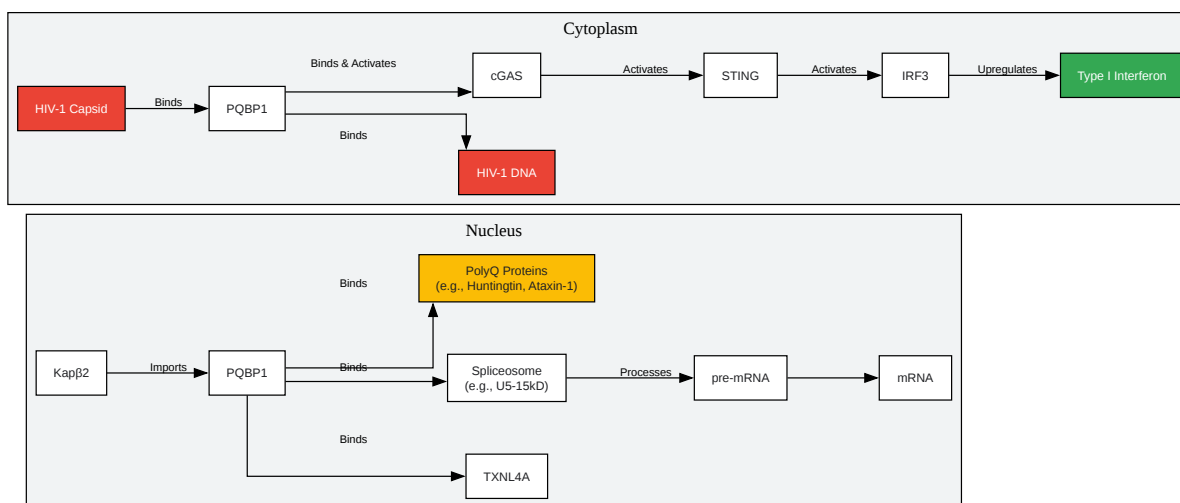

[Click to download full resolution via product page](#)

Caption: PQBP1 interaction pathways in the nucleus and cytoplasm.

Experimental Protocols

This section details two common in vitro assays to quantify PQBP1 binding: GST pull-down for protein-protein interactions and a DNA binding assay for protein-nucleic acid interactions.

Protocol 1: GST Pull-Down Assay for PQBP1 Protein-Protein Interaction

This protocol is designed to verify and quantify the interaction between a GST-tagged PQBP1 and a putative protein partner.

Materials:

- Recombinant GST-tagged PQBP1 (and GST alone as a control)
- Purified potential interacting protein (e.g., TXNL4A, cGAS)
- Glutathione-Sepharose beads
- Binding Buffer: 50 mM Tris-HCl pH 7.5, 150 mM NaCl, 1 mM EDTA, 0.1% NP-40, 1 mM DTT, Protease Inhibitor Cocktail
- Wash Buffer: Binding buffer with 300 mM NaCl
- Elution Buffer: 50 mM Tris-HCl pH 8.0, 10 mM reduced glutathione
- SDS-PAGE gels and buffers
- Western blot apparatus and reagents
- Antibody against the interacting protein

Experimental Workflow:

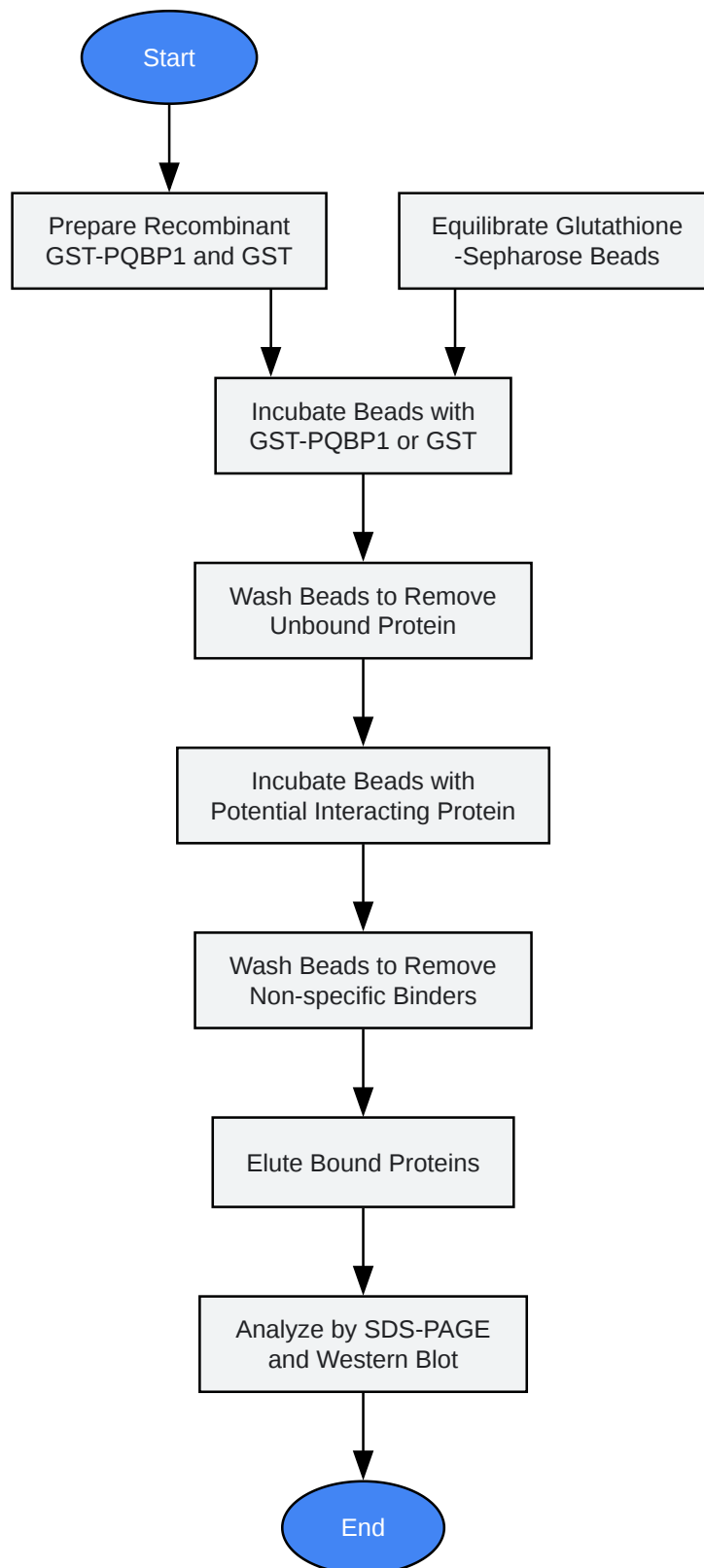

[Click to download full resolution via product page](#)

Caption: Workflow for the GST pull-down assay.

Procedure:

- **Bead Preparation:** Resuspend glutathione-sepharose beads in binding buffer.
- **Protein Immobilization:** Incubate 10-20 µg of GST-PQBP1 or GST with the equilibrated beads for 1 hour at 4°C with gentle rotation.
- **Washing:** Pellet the beads by centrifugation and wash three times with binding buffer to remove unbound protein.
- **Binding Reaction:** Add 10-20 µg of the purified potential interacting protein to the beads and incubate for 2-4 hours at 4°C with gentle rotation.
- **Washing:** Pellet the beads and wash five times with wash buffer.
- **Elution:** Elute the bound proteins by adding elution buffer and incubating for 10 minutes at room temperature.
- **Analysis:** Analyze the eluates by SDS-PAGE and Western blotting using an antibody specific to the interacting protein.

Protocol 2: In Vitro DNA Binding Assay for PQBP1

This protocol is adapted from methods used to study the interaction of PQBP1 with HIV-1 DNA.

[7]

Materials:

- Recombinant purified PQBP1 protein (e.g., GST-tagged)
- Target DNA (e.g., reverse-transcribed HIV-1 DNA, plasmid DNA)
- DNA Binding Buffer: 10 mM Tris-HCl pH 8.0, 50 mM KCl, 1 mM MgCl₂, 1 mM DTT
- Antibody for immunoprecipitation (e.g., anti-GST or anti-PQBP1)
- Protein A/G magnetic beads
- Wash Buffer: DNA Binding Buffer with 150 mM KCl

- DNA Elution Buffer: 100 mM NaHCO₃, 1% SDS
- qPCR reagents (primers specific for the target DNA, SYBR Green master mix)

Experimental Workflow:

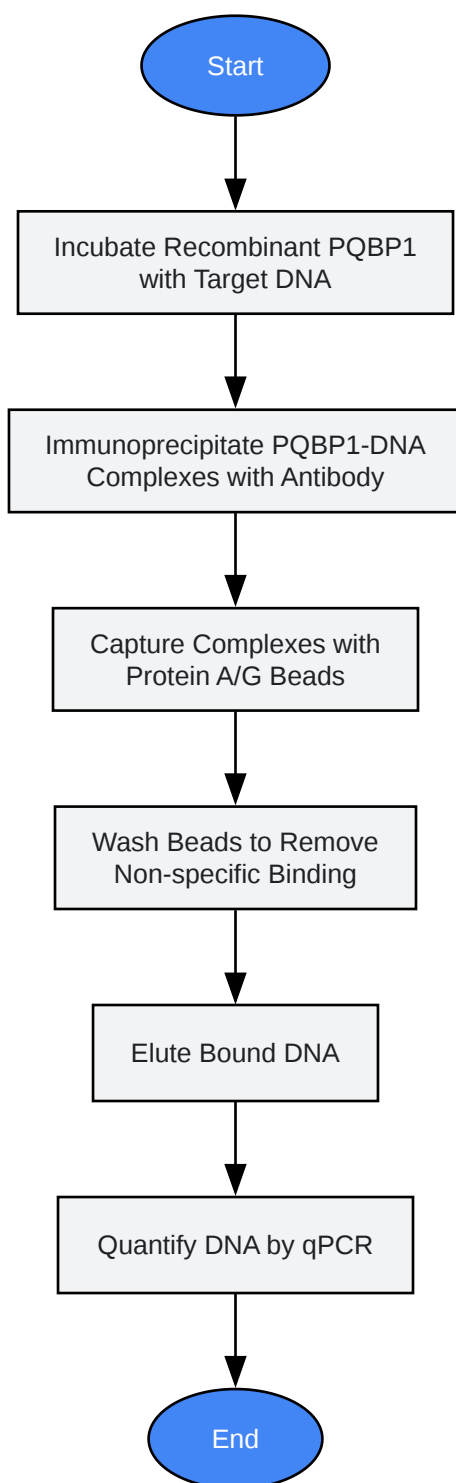

[Click to download full resolution via product page](#)

Caption: Workflow for the in vitro DNA binding assay.

Procedure:

- **Binding Reaction:** In a microcentrifuge tube, combine 300 ng of recombinant PQBP1 with 100 ng of target DNA in DNA binding buffer. Incubate for 1 hour at room temperature.
- **Immunoprecipitation:** Add 1-2 μg of the appropriate antibody and incubate for 2 hours at 4°C with gentle rotation.
- **Bead Capture:** Add pre-equilibrated Protein A/G magnetic beads and incubate for another hour at 4°C.
- **Washing:** Pellet the beads using a magnetic stand and wash three times with wash buffer.
- **Elution:** Resuspend the beads in DNA elution buffer and incubate at 65°C for 30 minutes to elute the DNA.
- **Analysis:** Purify the eluted DNA and quantify the amount of target DNA using qPCR with specific primers.

Data Presentation

Quantitative data from these assays should be presented in a clear and organized manner to facilitate comparison between different conditions or mutants.

Table 1: Quantification of PQBP1-Protein Interaction via GST Pull-Down

Bait Protein	Prey Protein	Input (Arbitrary Units)	Eluate (Arbitrary Units)	Relative Binding (%)
GST	Protein X	100	1.2	1.2
GST-PQBP1 (WT)	Protein X	100	45.8	45.8
GST-PQBP1 (Mutant)	Protein X	100	5.3	5.3

Relative Binding (%) is calculated as (Eluate / Input) * 100. Data are representative.

Table 2: Quantification of PQBP1-DNA Interaction via In Vitro Binding Assay

Protein	Target DNA	Input DNA (ng)	Bound DNA (% of Input)
GST-PQBP1 (WT)	HIV-1 DNA	100	15.2
GST-PQBP1 (delC)	HIV-1 DNA	100	2.1
GST-PQBP1 (WT)	Control Plasmid	100	0.8

Bound DNA (% of Input) is determined by qPCR analysis of the immunoprecipitated DNA compared to a standard curve of the input DNA. Data are representative.

These protocols provide a robust framework for investigating the molecular interactions of PQBP1. By quantifying these binding events, researchers can gain deeper insights into the mechanisms underlying PQBP1's function in health and disease, and screen for molecules that modulate its activity.

Need Custom Synthesis?

BenchChem offers custom synthesis for rare earth carbides and specific isotopic labeling.

Email: info@benchchem.com or [Request Quote Online](#).

References

- 1. PQBP1 - Wikipedia [en.wikipedia.org]
- 2. uniprot.org [uniprot.org]
- 3. communities.springernature.com [communities.springernature.com]
- 4. mdpi.com [mdpi.com]
- 5. mdpi.com [mdpi.com]
- 6. The Renpenning syndrome–associated protein PQBP1 facilitates the nuclear import of splicing factor TXNL4A through the karyopherin β 2 receptor - PMC [pmc.ncbi.nlm.nih.gov]
- 7. PQBP1 is a Proximal Sensor of the cGAS-dependent Innate Response to HIV-1 - PMC [pmc.ncbi.nlm.nih.gov]
- To cite this document: BenchChem. [Application Note & Protocol: In Vitro Assays to Measure PQBP1 Binding Activity]. BenchChem, [2025]. [Online PDF]. Available at: [https://www.benchchem.com/product/b610178#in-vitro-assay-to-measure-pqbp1-binding-activity]

Disclaimer & Data Validity:

The information provided in this document is for Research Use Only (RUO) and is strictly not intended for diagnostic or therapeutic procedures. While BenchChem strives to provide accurate protocols, we make no warranties, express or implied, regarding the fitness of this product for every specific experimental setup.

Technical Support: The protocols provided are for reference purposes. Unsure if this reagent suits your experiment? [[Contact our Ph.D. Support Team for a compatibility check](#)]

Need Industrial/Bulk Grade? [Request Custom Synthesis Quote](#)

BenchChem

Our mission is to be the trusted global source of essential and advanced chemicals, empowering scientists and researchers to drive progress in science and industry.

Contact

Address: 3281 E Guasti Rd

Ontario, CA 91761, United States

Phone: (601) 213-4426

Email: info@benchchem.com