

An In-Depth Technical Guide to Propargyl-PEG3-acid: Structure, Function, and Applications

Author: BenchChem Technical Support Team. **Date:** April 2026

Compound of Interest

Compound Name: *Propargyl-PEG3-acid*

CAS No.: *1347760-82-0*

Cat. No.: *B610230*

[Get Quote](#)

For Researchers, Scientists, and Drug Development Professionals

Introduction

Propargyl-PEG3-acid is a heterobifunctional linker widely utilized in bioconjugation, chemical biology, and medicinal chemistry. Its unique structure, featuring a terminal alkyne (propargyl group) and a carboxylic acid, connected by a flexible triethylene glycol (PEG3) spacer, allows for the covalent linkage of diverse molecular entities. This guide provides a comprehensive overview of the structure, functional groups, properties, and key applications of **Propargyl-PEG3-acid**, complete with experimental considerations and workflow visualizations to aid researchers in its effective implementation.

Molecular Structure and Functional Groups

Propargyl-PEG3-acid is characterized by three key components: a propargyl group, a polyethylene glycol (PEG) linker, and a carboxylic acid.

- **Propargyl Group:** This functional group contains a terminal alkyne (a carbon-carbon triple bond). The alkyne is a high-energy, reactive moiety that readily participates in copper-

catalyzed azide-alkyne cycloaddition (CuAAC), a cornerstone of "click chemistry."^[1] This reaction is highly specific, efficient, and biocompatible, making it ideal for conjugating the linker to molecules containing an azide group.^[1]

- **Polyethylene Glycol (PEG) Linker:** The PEG3 spacer consists of three repeating ethylene glycol units. This hydrophilic chain enhances the aqueous solubility of the molecule and any conjugate it is incorporated into.^{[2][3]} The flexibility of the PEG linker can also be advantageous in overcoming steric hindrance between the conjugated molecules.
- **Carboxylic Acid:** The terminal carboxylic acid is a versatile functional group that can be activated to form a stable amide bond with primary amines.^[3] This reaction is commonly achieved using coupling agents such as 1-Ethyl-3-(3-dimethylaminopropyl)carbodiimide (EDC) in the presence of N-hydroxysuccinimide (NHS) or its water-soluble analog, Sulfo-NHS.^{[2][4][5][6][7]}

The combination of these functional groups in a single molecule allows for orthogonal conjugation strategies, where the alkyne and carboxylic acid can be reacted independently with their respective partners.

Physicochemical and Quantitative Data

A summary of the key quantitative data for **Propargyl-PEG3-acid** is presented in the table below for easy reference and comparison.

Property	Value
IUPAC Name	3-(2-(2-(prop-2-yn-1-yloxy)ethoxy)ethoxy)propanoic acid[3]
CAS Number	1347760-82-0[3]
Molecular Formula	C ₁₀ H ₁₆ O ₅ [3][8]
Molecular Weight	216.23 g/mol [3][8]
Appearance	Liquid or Brown Liquid[8]
Purity	≥95% (NMR)[8], >96%[9], 98%[10]
Solubility	Water, DMSO, DCM, DMF[10]
Storage Conditions	-20°C for long term[3] or ≤ -10 °C[8]
SMILES String	C#CCOCCOCCOCCC(O)=O
InChI Key	CJNSWLAJTZVSRB-UHFFFAOYSA-N

Experimental Protocols and Methodologies

The utility of **Propargyl-PEG3-acid** lies in its ability to participate in two highly reliable conjugation reactions: Copper-Catalyzed Azide-Alkyne Cycloaddition (CuAAC) and EDC/NHS-mediated amide coupling.

Copper-Catalyzed Azide-Alkyne Cycloaddition (CuAAC)

This "click" reaction forms a stable triazole linkage between the propargyl group of the linker and an azide-functionalized molecule.

Materials:

- **Propargyl-PEG3-acid**
- Azide-containing molecule
- Copper(II) sulfate (CuSO₄)

- Sodium ascorbate
- Tris(3-hydroxypropyltriazolylmethyl)amine (THPTA) or other copper-chelating ligand
- Aqueous buffer (e.g., phosphate-buffered saline, PBS, pH 7.4)
- Organic co-solvent if needed (e.g., DMSO, DMF)

General Protocol:

- **Dissolve Reactants:** Dissolve the azide-containing molecule and **Propargyl-PEG3-acid** in the chosen reaction buffer. An organic co-solvent may be used to aid solubility.
- **Prepare Copper Catalyst:** In a separate tube, prepare a fresh solution of CuSO_4 and a copper-chelating ligand like THPTA in the reaction buffer. The ligand helps to stabilize the Cu(I) oxidation state and protect biomolecules from oxidative damage.
- **Initiate the Reaction:** Add the copper/ligand solution to the solution of reactants.
- **Add Reducing Agent:** Add a fresh solution of sodium ascorbate to the reaction mixture to reduce Cu(II) to the active Cu(I) catalyst.
- **Incubate:** Allow the reaction to proceed at room temperature with gentle agitation for 1-4 hours. Reaction progress can be monitored by analytical techniques such as LC-MS.
- **Purification:** Purify the conjugate using appropriate chromatographic techniques (e.g., size-exclusion chromatography, reversed-phase HPLC) to remove unreacted starting materials and the copper catalyst.

EDC/NHS Amide Coupling

This reaction forms a stable amide bond between the carboxylic acid of the linker and a primary amine-containing molecule.

Materials:

- **Propargyl-PEG3-acid**

- Amine-containing molecule
- 1-Ethyl-3-(3-dimethylaminopropyl)carbodiimide (EDC)
- N-hydroxysuccinimide (NHS) or N-hydroxysulfosuccinimide (Sulfo-NHS)
- Activation Buffer (e.g., 0.1 M MES, pH 4.7-6.0)
- Coupling Buffer (e.g., PBS, pH 7.2-8.5)
- Quenching solution (e.g., hydroxylamine, Tris, or glycine)
- Desalting column

General Protocol:

- **Activate Carboxylic Acid:** Dissolve **Propargyl-PEG3-acid** in the activation buffer. Add freshly prepared EDC and NHS (or Sulfo-NHS) to the solution. Incubate for 15-30 minutes at room temperature to form the amine-reactive NHS ester.
- **Remove Excess Reagents (Optional but Recommended):** Use a desalting column to remove excess EDC and NHS, exchanging the buffer to the coupling buffer in the process.
- **Couple to Amine:** Add the amine-containing molecule to the activated **Propargyl-PEG3-acid** solution. Incubate for 2 hours at room temperature or overnight at 4°C.
- **Quench the Reaction:** Add a quenching solution to terminate the reaction and consume any unreacted NHS esters.
- **Purification:** Purify the conjugate using appropriate chromatographic techniques to remove unreacted starting materials and byproducts.

Applications and Workflow Visualizations

Propargyl-PEG3-acid is a key component in the synthesis of complex biomolecules, particularly in the fields of targeted drug delivery and protein degradation.

Synthesis of Proteolysis-Targeting Chimeras (PROTACs)

PROTACs are heterobifunctional molecules that recruit a target protein to an E3 ubiquitin ligase, leading to the ubiquitination and subsequent degradation of the target protein.[11][12][13][14] **Propargyl-PEG3-acid** can serve as the linker connecting the target protein binder and the E3 ligase ligand.

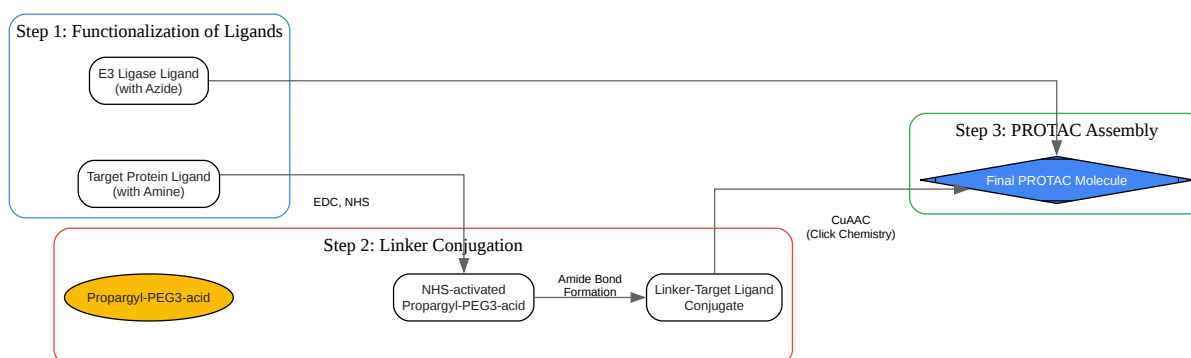

[Click to download full resolution via product page](#)

Caption: A generalized workflow for the synthesis of a PROTAC using **Propargyl-PEG3-acid** as a linker.

Synthesis of Antibody-Drug Conjugates (ADCs)

ADCs are targeted therapies that use a monoclonal antibody to deliver a potent cytotoxic drug specifically to cancer cells.[15][16][17] **Propargyl-PEG3-acid** can be used to link the antibody to the drug payload.

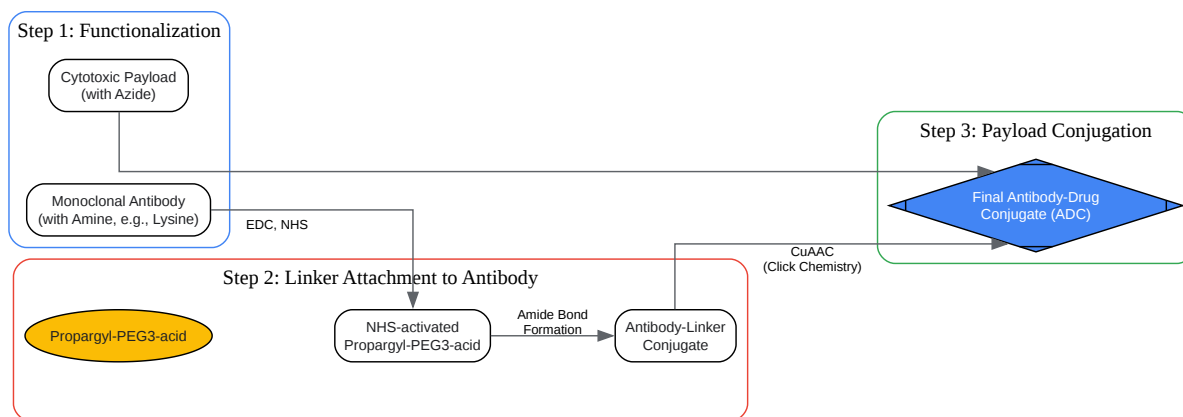

[Click to download full resolution via product page](#)

Caption: A generalized workflow for the synthesis of an ADC using **Propargyl-PEG3-acid** as a linker.

Conclusion

Propargyl-PEG3-acid is a versatile and powerful tool for researchers in the life sciences. Its well-defined structure, featuring orthogonal reactive handles and a solubilizing PEG spacer, enables the efficient and specific conjugation of a wide range of molecules. The applications in the development of next-generation therapeutics such as PROTACs and ADCs highlight its significance in advancing drug discovery and development. This guide provides the foundational knowledge and procedural outlines to facilitate the successful application of **Propargyl-PEG3-acid** in various research endeavors.

Need Custom Synthesis?

BenchChem offers custom synthesis for rare earth carbides and specific isotopic labeling.

Email: info@benchchem.com or [Request Quote Online](#).

References

- [1. medchemexpress.com \[medchemexpress.com\]](#)
- [2. General Protocol for Coupling Biomolecules to Carboxylate Particles using EDC/Sulfo-NHS \[echobiosystems.com\]](#)
- [3. medkoo.com \[medkoo.com\]](#)
- [4. info.gbiosciences.com \[info.gbiosciences.com\]](#)
- [5. ucl.ac.uk \[ucl.ac.uk\]](#)
- [6. documents.thermofisher.com \[documents.thermofisher.com\]](#)
- [7. covachem.com \[covachem.com\]](#)
- [8. chemimpex.com \[chemimpex.com\]](#)
- [9. precisepeg.com \[precisepeg.com\]](#)
- [10. Propargyl-PEG3-acid, 1347760-82-0 | BroadPharm \[broadpharm.com\]](#)
- [11. Current strategies for the design of PROTAC linkers: a critical review - PMC \[pmc.ncbi.nlm.nih.gov\]](#)
- [12. symeres.com \[symeres.com\]](#)
- [13. medchemexpress.com \[medchemexpress.com\]](#)
- [14. Workflow for E3 Ligase Ligand Validation for PROTAC Development - PMC \[pmc.ncbi.nlm.nih.gov\]](#)
- [15. Methods to Design and Synthesize Antibody-Drug Conjugates \(ADCs\) - PMC \[pmc.ncbi.nlm.nih.gov\]](#)
- [16. Synthesis of a heterotrifunctional linker for the site-specific preparation of antibody-drug conjugates with two distinct warheads - PubMed \[pubmed.ncbi.nlm.nih.gov\]](#)
- [17. adc.bocsci.com \[adc.bocsci.com\]](#)
- To cite this document: BenchChem. [An In-Depth Technical Guide to Propargyl-PEG3-acid: Structure, Function, and Applications]. BenchChem, [2026]. [Online PDF]. Available at: [<https://www.benchchem.com/product/b610230/docs#an-in-depth-technical-guide-to-propargyl-peg3-acid-structure-function-and-applications>]

Disclaimer & Data Validity:

The information provided in this document is for Research Use Only (RUO) and is strictly not intended for diagnostic or therapeutic procedures. While BenchChem strives to provide accurate protocols, we make no warranties, express or implied, regarding the fitness of this product for every specific experimental setup.

Technical Support: The protocols provided are for reference purposes. Unsure if this reagent suits your experiment?

Need Industrial/Bulk Grade? [Request Custom Synthesis Quote](#)

BenchChem

Our mission is to be the trusted global source of essential and advanced chemicals, empowering scientists and researchers to drive progress in science and industry.

Contact

Address: 3281 E Guasti Rd
Ontario, CA 91761, United States
Phone: (601) 213-4426
Email: info@benchchem.com

[Contact our Ph.D. Support Team for a compatibility check](#)