

using (R)-(-)-DBD-Py-NCS for chiral analysis of complex biological samples

Author: BenchChem Technical Support Team. **Date:** May 2026

Compound of Interest

Compound Name: (R)-(-)-DBD-Py-NCS

CAS No.: 163927-31-9

Cat. No.: B061319

[Get Quote](#)

Application Note & Protocol

High-Sensitivity Chiral Analysis of Amino Acids and Primary Amines in Complex Biological Samples using (R)-(-)-DBD-Py-NCS by LC-MS/MS

Abstract

The enantioselective analysis of chiral molecules, such as amino acids and biogenic amines, is of paramount importance in drug development, clinical diagnostics, and metabolomics, as enantiomers can exhibit distinct physiological and pharmacological activities.[1] This application note presents a comprehensive guide and a robust protocol for the chiral analysis of primary and secondary amines in complex biological matrices, specifically human plasma. The methodology is centered around pre-column derivatization with the novel chiral reagent, (R)-(-)-4-(N,N-dimethylaminosulfonyl)-7-(3-isothiocyanatopyrrolidin-1-yl)-2,1,3-benzoxadiazole, commonly known as **(R)-(-)-DBD-Py-NCS**.

This indirect chiral separation approach involves the reaction of the enantiomeric analytes with the enantiomerically pure **(R)-(-)-DBD-Py-NCS** to form stable diastereomeric thiourea derivatives. These diastereomers, possessing distinct physicochemical properties, are then baseline-separated on a standard achiral reversed-phase C18 column and detected with high sensitivity and selectivity using tandem mass spectrometry (LC-MS/MS). We provide a detailed, step-by-step protocol covering plasma sample preparation, derivatization, LC-MS/MS analysis, and method validation considerations. This guide is intended for researchers, scientists, and drug development professionals seeking to implement a reliable and sensitive method for chiral amine analysis.

Introduction: The Imperative of Chiral Separation

In biological systems, chirality dictates molecular recognition and, consequently, function. While L-amino acids are the fundamental building blocks of proteins, their D-enantiomers are increasingly recognized as crucial signaling molecules and biomarkers for various pathological conditions, including neurological disorders and certain cancers.[2] Therefore, the ability to accurately quantify the enantiomeric excess (%ee) or concentration of individual enantiomers in complex biological fluids is a critical analytical challenge.[3]

Direct enantioseparation on chiral stationary phases (CSPs) can be effective but often suffers from high column costs, limited robustness, and challenges with LC-MS compatibility.[4][5] The indirect method, utilizing a chiral derivatizing agent (CDA), circumvents these issues. By converting the enantiomers into diastereomers, separation can be achieved on conventional, robust, and cost-effective achiral columns.[6]

(R)-(-)-DBD-Py-NCS: A Superior Reagent for Chiral Derivatization

(R)-(-)-DBD-Py-NCS is an advanced chiral derivatizing agent designed for high-sensitivity analysis of primary and secondary amines. Its key advantages include:

- **High Reactivity:** The isothiocyanate (-NCS) group reacts efficiently and specifically with primary and secondary amines under mild conditions to form a stable thiourea linkage.
- **Built-in Chiral Center:** The (R)-pyrrolidine moiety provides the necessary chirality to form distinct diastereomers with chiral analytes.

- **Excellent Ionization Efficiency:** The N,N-dimethylaminosulfonyl-benzoxadiazole structure contains a permanently ionized dimethylamino group, which promotes excellent ionization efficiency in electrospray ionization (ESI) mass spectrometry, leading to low detection limits.
- **Predictable Fragmentation:** The derivative structure allows for predictable fragmentation patterns in MS/MS, facilitating the development of sensitive and specific Multiple Reaction Monitoring (MRM) methods.

The Chemistry: Mechanism of Derivatization

The core of this analytical method is the nucleophilic addition of the amine analyte to the electrophilic isothiocyanate group of **(R)-(-)-DBD-Py-NCS**. The reaction proceeds under mild basic conditions, which enhance the nucleophilicity of the amine.

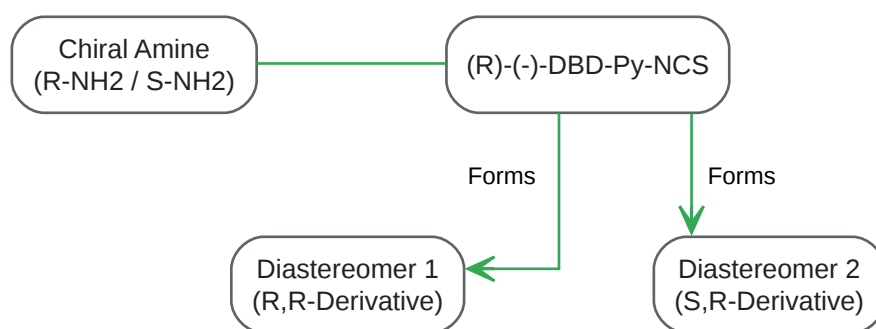

[Click to download full resolution via product page](#)

Caption: Overall workflow for chiral amine analysis in plasma.

Step-by-Step Methodology

Step 1: Preparation of Reagents

- **Derivatization Buffer (100 mM Borate Buffer, pH 9.5):** Dissolve boric acid in LC-MS grade water to a concentration of 100 mM. Adjust the pH to 9.5 with 1 M sodium hydroxide.
- **(R)-(-)-DBD-Py-NCS Solution (1.5 mg/mL):** Prepare fresh daily. Dissolve **(R)-(-)-DBD-Py-NCS** in acetonitrile to a final concentration of 1.5 mg/mL. Protect from light.
- **Catalyst Solution (5% v/v TEA in Acetonitrile):** Add 50 μ L of triethylamine to 950 μ L of acetonitrile.

- Quenching Solution (2% Formic Acid in Water): Add 200 μL of formic acid to 9.8 mL of LC-MS grade water.

Step 2: Sample Preparation (Protein Precipitation)

- Thaw frozen human plasma samples on ice.
- To a 1.5 mL microcentrifuge tube, add 100 μL of plasma.
- Add 400 μL of ice-cold acetonitrile. This 4:1 ratio of acetonitrile to plasma is effective for precipitating the majority of plasma proteins. [7]4. Vortex vigorously for 1 minute to ensure thorough mixing and protein denaturation.
- Centrifuge at 14,000 x g for 10 minutes at 4°C.
- Carefully transfer 300 μL of the clear supernatant to a new 1.5 mL microcentrifuge tube, avoiding the pelleted protein.

Step 3: Derivatization Reaction

- To the 300 μL of supernatant, add 100 μL of the 100 mM Borate Buffer (pH 9.5).
- Add 50 μL of the **(R)-(-)-DBD-Py-NCS** solution (1.5 mg/mL).
- Add 20 μL of the 5% TEA catalyst solution.
- Vortex the mixture for 30 seconds.
- Incubate the reaction mixture at 60°C for 45 minutes in a heating block, protected from light. Optimization of temperature and time may be necessary for specific analytes to ensure complete reaction without degradation. [8]6. After incubation, cool the mixture to room temperature.
- Add 20 μL of the 2% formic acid quenching solution to stop the reaction and stabilize the derivatives. Vortex briefly.
- Filter the final solution through a 0.22 μm syringe filter or a filter vial into an LC autosampler vial. The sample is now ready for injection.

Parameter	Recommended Condition	Rationale
pH	9.5	Enhances the nucleophilicity of the primary/secondary amine for efficient reaction.
Temperature	60°C	Provides sufficient energy to drive the reaction to completion in a reasonable timeframe.
Time	45 minutes	Ensures the derivatization reaction reaches completion for most small amine analytes.
Reagent Ratio	>3-fold molar excess	A significant excess of the derivatizing reagent ensures quantitative conversion of the analyte.
Catalyst	Triethylamine (TEA)	A non-nucleophilic base that facilitates the reaction without competing with the analyte.

Table 1: Key parameters and their scientific justification for the derivatization of amines in plasma extracts with **(R)-(-)-DBD-Py-NCS**.

LC-MS/MS Analysis

Chromatographic Conditions

The diastereomers are separated on a standard C18 column. The increased hydrophobicity of the DBD-Py-NCS tag allows for excellent retention and resolution.

Parameter	Recommended Condition
Column	C18 Reversed-Phase (e.g., 2.1 x 100 mm, 1.8 μ m)
Mobile Phase A	0.1% Formic Acid in Water
Mobile Phase B	0.1% Formic Acid in Acetonitrile
Flow Rate	0.4 mL/min
Column Temp.	40°C
Injection Vol.	5 μ L
Gradient	0-2 min: 20% B; 2-10 min: 20-80% B; 10-12 min: 80% B; 12-12.1 min: 80-20% B; 12.1-15 min: 20% B

Table 2: Recommended starting HPLC/UPLC conditions for the separation of DBD-Py-NCS diastereomers.

Mass Spectrometry Conditions

Analysis is performed using an ESI source in positive ion mode. MRM is used for quantification to ensure the highest sensitivity and selectivity.

Rationale for MRM Transition Selection: The precursor ion ($[M+H]^+$) will be the mass of the derivatized amino acid. The most common and stable fragmentation occurs at the thiourea bond or within the DBD-Py-NCS tag itself. A common, highly abundant product ion derived from the DBD-Py-NCS structure can often be used as a "quantifier" transition for all analytes, while a second, analyte-specific fragment can be used as a "qualifier" transition. Based on the structure of DBD-Py-NCS (MW: 353.42), a significant product ion is expected from the cleavage of the thiourea linkage, resulting in a fragment corresponding to the protonated DBD-Py moiety.

Analyte (Example)	Precursor Ion (m/z)	Product Ion 1 (Quantifier)	Product Ion 2 (Qualifier)
Alanine (D/L)	443.1	308.1	197.1
Valine (D/L)	471.2	308.1	225.1
Leucine (D/L)	485.2	308.1	239.1
Phenylalanine (D/L)	519.2	308.1	273.1

Table 3: Proposed Multiple Reaction Monitoring (MRM) transitions for selected amino acid-DBD-Py-NCS derivatives. These should be empirically optimized on your specific mass spectrometer.

Method Validation and Troubleshooting

A full method validation should be performed according to regulatory guidelines (e.g., FDA or EMA) to ensure reliable results.

Validation Parameter	Acceptance Criteria (Typical)
Linearity	$r^2 > 0.99$
Lower Limit of Quantification (LLOQ)	S/N > 10, Accuracy within $\pm 20\%$, Precision <20% CV
Accuracy (Bias)	Within $\pm 15\%$ of nominal value ($\pm 20\%$ at LLOQ)
Precision (CV)	<15% (Intra- and Inter-day), <20% at LLOQ
Matrix Effect	Assessed and minimized; compensated with stable isotope-labeled internal standards if necessary.
Recovery	Consistent, precise, and reproducible.

Table 4: Summary of typical validation parameters and acceptance criteria for bioanalytical methods.

Troubleshooting Common Issues:

- **Low Derivatization Efficiency:** Ensure the derivatization reagent is fresh and protected from light. Verify the pH of the buffer. Check for competing amines (e.g., Tris buffer) in the sample matrix. [9]* **Matrix Effects (Ion Suppression/Enhancement):** Complex biological samples can contain co-eluting substances that affect the ionization of the target analyte. [10] To mitigate this, improve sample cleanup (e.g., using SPE), adjust chromatography to separate interferences, or use a stable isotope-labeled internal standard that co-elutes with the analyte.
- **Peak Tailing or Splitting:** This may indicate issues with the chromatography or incomplete reaction. Ensure the quenching step is effective. Check for column degradation.
- **Racemization:** Although the isothiocyanate reaction is generally mild, avoid excessively high temperatures or harsh pH conditions during sample preparation and derivatization to prevent potential racemization of the analyte. [11]

Conclusion

The use of **(R)-(-)-DBD-Py-NCS** as a chiral derivatizing agent provides a powerful and robust strategy for the enantioselective analysis of amino acids and other primary/secondary amines in complex biological matrices. The protocol detailed in this application note offers a comprehensive workflow from sample preparation to LC-MS/MS detection. The resulting diastereomers exhibit excellent chromatographic separation on standard achiral columns, and the physicochemical properties of the DBD-Py-NCS tag ensure high ionization efficiency and sensitive detection. By following the outlined procedures and validation guidelines, researchers can develop and implement a highly reliable and sensitive method to advance their studies in pharmacology, metabolomics, and clinical research.

References

- Toledo, G., et al. (2021). Fast and reliable method for analysis of derivatized plasma amino acids by liquid chromatography-single quadrupole-mass spectrometry. *Journal of Animal Science*. Available at: [[Link](#)]
- Tcherkas, Y. V., et al. (2005). Simple and rapid quantitative high-performance liquid chromatographic analysis of plasma amino acids. *Clinical Chimica Acta*. Available at: [[Link](#)]

- ResearchGate. (n.d.). Derivatization reaction optimization. ResearchGate. Available at: [\[Link\]](#)
- ResearchGate. (n.d.). Derivatization reaction of DBD-PyNCS with d-amino acid. ResearchGate. Available at: [\[Link\]](#)
- SickKids Research Institute. (n.d.). Sample Preparation - SPARC BioCentre Molecular Analysis. SickKids Research Institute. Available at: [\[Link\]](#)
- Agilent. (n.d.). Routine Quantitation of 17 Underivatized Amino Acids by LCMS. Agilent. Available at: [\[Link\]](#)
- Sultan, A., et al. (2018). analysis of amino acids by high performance liquid chromatography. The Professional Medical Journal. Available at: [\[Link\]](#)
- Restek Corporation. (2021). 13-Minute, Comprehensive, Direct LC-MS/MS Analysis of Amino Acids in Plasma. Restek Corporation. Available at: [\[Link\]](#)
- Teerlink, T., et al. (1995). Validation of the determination of amino acids in plasma by high-performance liquid chromatography using automated pre-column derivatization with o-phthaldialdehyde. Journal of Chromatography B: Biomedical Applications. Available at: [\[Link\]](#)
- ResearchGate. (n.d.). Multiple reaction monitoring (MRM) transitions and dwell times for the seven amino acids and corresponding internal standards monitored in this study. ResearchGate. Available at: [\[Link\]](#)
- ResearchGate. (n.d.). MRM ion transitions for all target amino acids. ResearchGate. Available at: [\[Link\]](#)
- ResearchGate. (n.d.). Optimized MRM transition parameters for the analyzed amino acids. ResearchGate. Available at: [\[Link\]](#)
- ResearchGate. (n.d.). Optimizing Amino Acid Derivatization in Food Matrices. ResearchGate. Available at: [\[Link\]](#)
- Ng, D., et al. (2023). A novel screening method for free non-standard amino acids in human plasma samples using AccQ-Tag reagents and LC-MS/MS. Analytical Methods. Available at: [\[Link\]](#)

- Armstrong, D. W., et al. (2022). Analysis of D-Amino Acids: Relevance in Human Disease. LCGC International. Available at: [\[Link\]](#)
- Yoshida, H., et al. (2015). Validation of an Analytical Method for Human Plasma Free Amino Acids by High-Performance Liquid Chromatography Ionization Mass Spectrometry Using Automated Precolumn Derivatization. Journal of Chromatography B. Available at: [\[Link\]](#)
- Santos, F., et al. (2024). Optimizing Amino Acid Derivatization in Food Matrices. MDPI. Available at: [\[Link\]](#)
- Teerlink, T., et al. (1995). Validation of the determination of amino acids in plasma by high-performance liquid chromatography using automated pre-column derivatization with o-phthaldialdehyde. Journal of Chromatography B: Biomedical Applications. Available at: [\[Link\]](#)
- Chemistry LibreTexts. (2023). Mass Spectrometry - Fragmentation Patterns. Chemistry LibreTexts. Available at: [\[Link\]](#)
- Chen, Y., et al. (2012). Structure guided RP-HPLC chromatography of diastereomeric α -helical peptide analogs substituted with single amino acid stereoisomers. Journal of Chromatography B. Available at: [\[Link\]](#)
- Wang, Y., et al. (2023). A Practical Method for Amino Acid Analysis by LC-MS Using Precolumn Derivatization with Urea. MDPI. Available at: [\[Link\]](#)
- ResearchGate. (n.d.). Determination of Trace Amounts of Chiral Amino Acids in Complicated Biological Samples Using Two-Dimensional High-Performance Liquid Chromatography with an Innovative "Shape-Fitting" Peak Identification/Quantification Method. ResearchGate. Available at: [\[Link\]](#)
- ResearchGate. (2019). Is there a "gold standard" for amino acid derivatization for LC/MS analysis?. ResearchGate. Available at: [\[Link\]](#)
- Tolbert, D., et al. (2022). Analytical Validation of an Assay for Concurrent Measurement of Amino Acids in Dog Serum and Comparison of Amino Acid Concentrations between Whole Blood, Plasma, and Serum from Dogs. MDPI. Available at: [\[Link\]](#)

- Chemistry LibreTexts. (2022). Amine Fragmentation. Chemistry LibreTexts. Available at: [\[Link\]](#)
- ResearchGate. (n.d.). Fragmentation of protonated dansyl-labeled amines for structural analysis of amine-containing metabolites. ResearchGate. Available at: [\[Link\]](#)
- University of Colorado Boulder. (n.d.). Mass Spectrometry: Fragmentation. University of Colorado Boulder. Available at: [\[Link\]](#)
- Wang, Y., et al. (2023). Study on the Mass Spectrometry Fragmentation Patterns for Rapid Screening and Structure Identification of Ketamine Analogues in Illicit Powders. Molecules. Available at: [\[Link\]](#)

Need Custom Synthesis?

BenchChem offers custom synthesis for rare earth carbides and specific isotopic labeling.

Email: info@benchchem.com or [Request Quote Online](#).

Sources

- [1. pdf.benchchem.com](https://pdf.benchchem.com) [pdf.benchchem.com]
- [2. researchgate.net](https://researchgate.net) [researchgate.net]
- [3. researchgate.net](https://researchgate.net) [researchgate.net]
- [4. sigmaaldrich.com](https://sigmaaldrich.com) [sigmaaldrich.com]
- [5. sigmaaldrich.com](https://sigmaaldrich.com) [sigmaaldrich.com]
- [6. Structure guided RP-HPLC chromatography of diastereomeric \$\alpha\$ -helical peptide analogs substituted with single amino acid stereoisomers - PMC](#) [[pmc.ncbi.nlm.nih.gov](https://pubmed.ncbi.nlm.nih.gov/)]
- [7. Fast and reliable method for analysis of derivatized plasma amino acids by liquid chromatography-single quadrupole-mass spectrometry - PMC](#) [[pmc.ncbi.nlm.nih.gov](https://pubmed.ncbi.nlm.nih.gov/)]
- [8. researchgate.net](https://researchgate.net) [researchgate.net]
- [9. Sample Preparation - SPARC BioCentre Molecular Analysis](https://lab.research.sickkids.ca) [lab.research.sickkids.ca]
- [10. pdf.benchchem.com](https://pdf.benchchem.com) [pdf.benchchem.com]

- 11. Separation of D and L amino acids by liquid chromatography: use of chiral eluants - PubMed [pubmed.ncbi.nlm.nih.gov]
- To cite this document: BenchChem. [using (R)-(-)-DBD-Py-NCS for chiral analysis of complex biological samples]. BenchChem, [2026]. [Online PDF]. Available at: [https://www.benchchem.com/product/b061319/docs#using-r-dbd-py-ncs-for-chiral-analysis-of-complex-biological-samples]

Disclaimer & Data Validity:

The information provided in this document is for Research Use Only (RUO) and is strictly not intended for diagnostic or therapeutic procedures. While BenchChem strives to provide accurate protocols, we make no warranties, express or implied, regarding the fitness of this product for every specific experimental setup.

Technical Support: The protocols provided are for reference purposes. Unsure if this reagent suits your experiment?

Need Industrial/Bulk Grade? [Request Custom Synthesis Quote](#)

BenchChem

Our mission is to be the trusted global source of essential and advanced chemicals, empowering scientists and researchers to drive progress in science and industry.

Contact

Address: 3281 E Guasti Rd
Ontario, CA 91761, United States
Phone: (601) 213-4426
Email: info@benchchem.com

[Contact our Ph.D. Support Team for a compatibility check](#)