

# GC-MS parameters for detecting pentedrone in biological matrices

**Author:** BenchChem Technical Support Team. **Date:** April 2026

## Compound of Interest

Compound Name:	Pentedrone
CAS No.:	879722-57-3
Cat. No.:	B609907

[Get Quote](#)

An Application Note for the Confirmatory Analysis of **Pentedrone** in Biological Matrices by Gas Chromatography-Mass Spectrometry (GC-MS)

## Introduction: The Analytical Challenge of Synthetic Cathinones

**Pentedrone** ( $\alpha$ -methylamino-valerophenone) is a synthetic cathinone, a class of novel psychoactive substances (NPS) designed to mimic the stimulant effects of controlled substances like amphetamine and MDMA.[1] As part of a constantly evolving market, these substances pose a significant challenge to clinical and forensic toxicology laboratories.[2] Their structural similarity to other cathinones and potential for extensive metabolism necessitate robust and validated analytical methods for unambiguous identification and quantification in complex biological matrices such as blood, urine, and oral fluid.[3]

This guide provides a comprehensive framework for the analysis of **pentedrone** using Gas Chromatography-Mass Spectrometry (GC-MS). It synthesizes field-proven methodologies, explaining the rationale behind critical steps from sample preparation to data interpretation, to equip researchers and drug development professionals with a reliable analytical protocol.

# The Analytical Workflow: A Step-by-Step Approach

The successful detection of **pentedrone** is contingent on a multi-stage process that includes efficient extraction from the biological matrix, chemical modification (derivatization) to ensure suitability for GC-MS analysis, and finally, optimized instrumental analysis.

## Part 1: Sample Preparation - Isolating the Analyte

The initial and most critical phase is the extraction of **pentedrone** from the biological sample. The goal is to isolate the target analyte from endogenous interferences (lipids, proteins, salts) that can compromise chromatographic performance and instrument longevity. The two most common and effective techniques are Liquid-Liquid Extraction (LLE) and Solid-Phase Extraction (SPE).

LLE is a classic technique that partitions the analyte between the aqueous biological sample and an immiscible organic solvent. For basic compounds like **pentedrone**, the pH of the aqueous phase is raised to deprotonate the amine group, increasing its affinity for the organic solvent.

Causality: By making the sample alkaline (pH > 9-10), the **pentedrone** molecule is neutralized, rendering it more soluble in a non-polar organic solvent like ethyl acetate or butyl acetate. This pH adjustment is fundamental to driving the equilibrium of the extraction in favor of moving the analyte out of the aqueous matrix and into the organic phase.[4][5]

Step-by-Step LLE Protocol (Urine/Oral Fluid):

- Sample Aliquot: Pipette 1.0 mL of the biological sample (e.g., urine, plasma, or oral fluid) into a 10 mL glass tube.
- Internal Standard: Add an appropriate internal standard (e.g., **pentedrone-d5** or a structurally similar compound like methylone-d3) to all samples, calibrators, and controls.[6][7]
- Alkalinization: Add a basifying agent, such as 200  $\mu$ L of 0.5 M ammonium hydrogen carbonate or a saturated sodium borate buffer, to adjust the sample pH to >9.[7]
- Extraction: Add 3 mL of a suitable organic solvent (e.g., ethyl acetate).

- **Mixing:** Cap the tube and vortex for 2 minutes, then gently rock for 10 minutes to ensure thorough mixing and partitioning.
- **Phase Separation:** Centrifuge at 3,000 rpm for 5 minutes to separate the aqueous and organic layers.
- **Collection:** Carefully transfer the upper organic layer to a clean tube.
- **Evaporation:** Evaporate the organic solvent to dryness under a gentle stream of nitrogen at approximately 40°C. The dried residue is now ready for derivatization.

SPE utilizes a solid sorbent packed into a cartridge or pipette tip to retain the analyte while the matrix passes through. The analyte is then eluted with a small volume of solvent. Mixed-mode cation exchange sorbents are particularly effective for basic drugs like **pentedrone**.[\[8\]](#)[\[9\]](#)

**Causality:** SPE offers superior cleanup compared to LLE, resulting in cleaner extracts and potentially higher analyte recovery, especially at low concentrations.[\[10\]](#)[\[11\]](#) The use of mixed-mode cartridges allows for a multi-faceted retention mechanism (e.g., hydrophobic and ion-exchange), providing enhanced selectivity for the target analyte.[\[8\]](#)

#### Step-by-Step SPE Protocol (Blood/Urine):

- **Sample Pre-treatment:** Centrifuge whole blood samples and use the resulting plasma. Dilute urine or plasma samples 1:1 with a buffer (e.g., 0.1 M phosphate buffer, pH 6.0).[\[9\]](#) Add an internal standard.
- **Cartridge Conditioning:** Condition a mixed-mode cation exchange SPE cartridge (e.g., SCX) by sequentially passing 1 mL of methanol and 1 mL of 0.1 M phosphate buffer (pH 6.0) through the sorbent.[\[9\]](#)
- **Sample Loading:** Load the pre-treated sample onto the conditioned cartridge. Allow the sample to pass through slowly under gravity or gentle vacuum.
- **Washing:** Wash the cartridge to remove interferences. A typical wash sequence is 1 mL of 1 M acetic acid followed by 1 mL of methanol.[\[9\]](#)

- Drying: Dry the cartridge thoroughly under high vacuum for 5-10 minutes to remove any residual water or wash solvents.
- Elution: Elute the analyte with 1 mL of a freshly prepared basic organic solvent mixture, such as 2% ammonium hydroxide in dichloromethane/isopropanol (95:5, v/v).[9]
- Evaporation: Collect the eluate and evaporate to dryness under a gentle stream of nitrogen at approximately 40°C. The residue is now ready for derivatization.

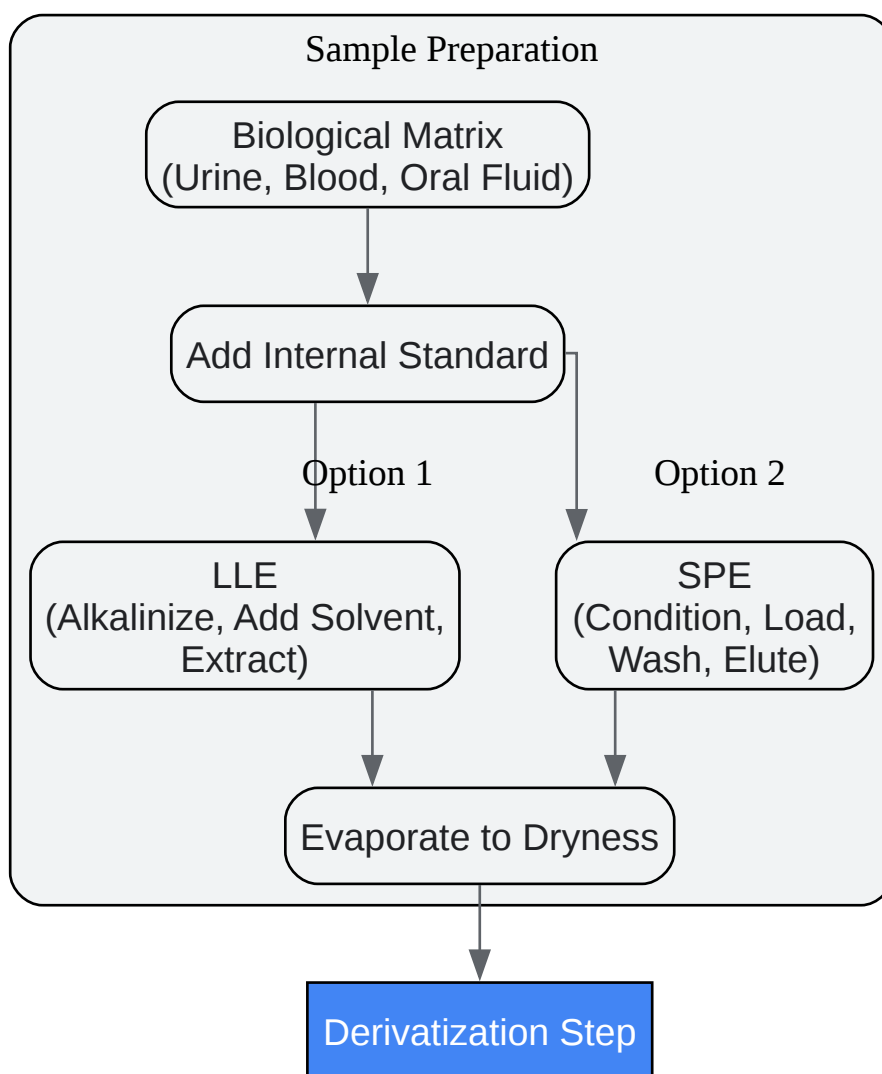

[Click to download full resolution via product page](#)

Fig 1. General sample preparation workflow for **pentedrone** analysis.

## Part 2: Derivatization - Enhancing Analyte Volatility and Stability

Derivatization is a chemical modification step that is often essential for the successful GC-MS analysis of synthetic cathinones.[12] **Pentedrone** contains a secondary amine and a ketone group, which can lead to poor peak shape and thermal degradation in the hot GC inlet. Converting the amine group to a less polar, more thermally stable derivative overcomes these issues.

Causality: Acylation reagents like pentafluoropropionic anhydride (PFPA) or trifluoroacetic anhydride (TFAA) react with the secondary amine of **pentedrone**. This reaction replaces the active hydrogen on the nitrogen with a fluorinated acyl group, which masks the polar N-H bond. The resulting derivative is more volatile, more thermally stable, and exhibits better chromatographic behavior (i.e., sharper, more symmetrical peaks), leading to improved sensitivity and reproducibility.[12][13] Studies comparing various agents have found that fluorinated anhydrides like PFPA and heptafluorobutyric anhydride (HFBA) are excellent choices.[12][13]

Step-by-Step Derivatization Protocol:

- Reagent Addition: To the dried sample extract, add 50  $\mu$ L of ethyl acetate and 50  $\mu$ L of a derivatizing agent (e.g., PFPA or TFAA).[6][14]
- Incubation: Cap the vial tightly and heat at 65-70°C for 15-20 minutes.[14]
- Evaporation: After incubation, cool the vial to room temperature and evaporate the reagent and solvent to dryness under a gentle stream of nitrogen.
- Reconstitution: Reconstitute the final derivatized residue in 50-100  $\mu$ L of a suitable solvent (e.g., ethyl acetate or methanol) for injection into the GC-MS.[6][15]

## Part 3: GC-MS Instrumental Analysis

The final step is the separation and detection of the derivatized **pentedrone** using GC-MS. The parameters must be optimized to ensure good chromatographic resolution from other compounds and a characteristic mass spectrum for confident identification.

Causality: The GC oven temperature program is designed to separate compounds based on their boiling points and interaction with the stationary phase of the column. A ramped program, starting at a lower temperature and increasing, allows for the elution of more volatile compounds first, followed by less volatile ones like derivatized **pentedrone**, ensuring good separation.[16] In the mass spectrometer, electron ionization (EI) at 70 eV provides reproducible fragmentation patterns that act as a chemical fingerprint for the analyte.[17] Operating in full scan mode allows for the collection of all fragment ions, which is ideal for initial identification, while selected ion monitoring (SIM) can be used for higher sensitivity quantification if needed.

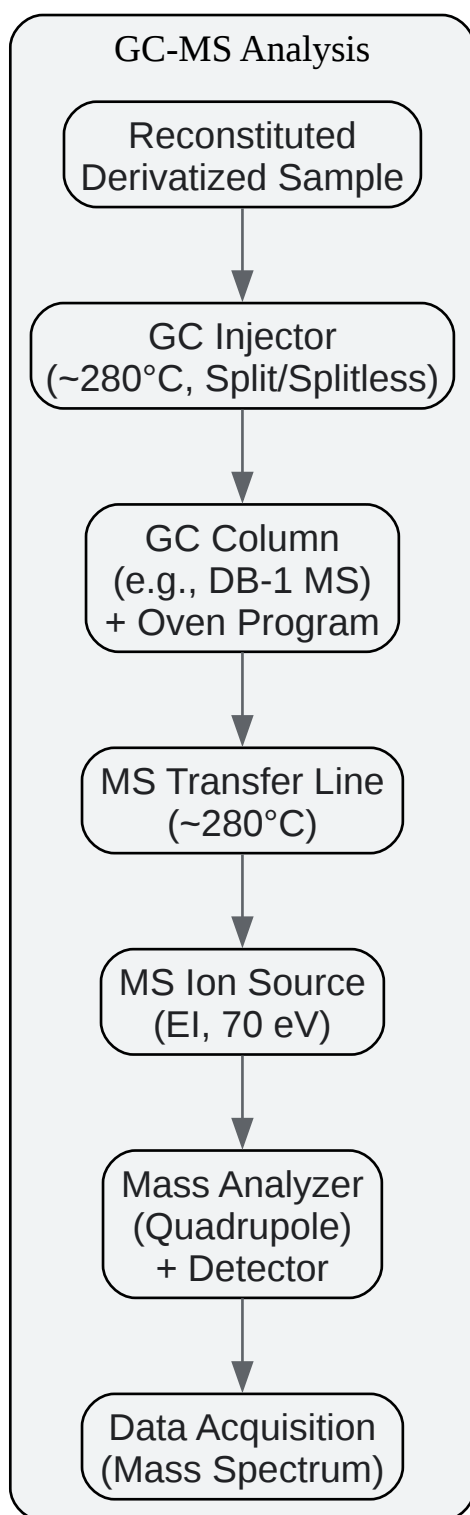

[Click to download full resolution via product page](#)

Fig 2. Key stages of the GC-MS analysis workflow.

The following table summarizes a typical set of GC-MS parameters for **pentadron** analysis, based on authoritative sources.[\[16\]](#)

Parameter	Recommended Setting	Rationale
Gas Chromatograph (GC)		
Column	DB-1 MS (or equivalent), 30 m x 0.25 mm ID, 0.25 µm film	A non-polar column providing good separation for a wide range of compounds.
Carrier Gas	Helium, constant flow at 1.0 mL/min	Inert carrier gas, standard for GC-MS applications.
Injector Temperature	280°C	Ensures rapid volatilization of the derivatized analyte without degradation.
Injection Mode	Split (e.g., 25:1) or Splitless	Split mode is used for concentrated samples, while splitless is for trace analysis.
Injection Volume	1 µL	Standard injection volume.
Oven Program	Initial: 100°C, hold 1 min. Ramp: 12°C/min to 300°C. Final Hold: 9 min.	This program provides good separation of pentedrone from other analytes.[16]
Mass Spectrometer (MS)		
MS Transfer Line	280°C	Prevents analyte condensation between the GC and MS.
Ion Source Temp.	230°C	Standard temperature for robust ionization.
Ionization Mode	Electron Ionization (EI) at 70 eV	Standard energy for generating reproducible, library-searchable mass spectra.
Acquisition Mode	Full Scan	Collects all fragment ions for definitive identification.
Mass Scan Range	30-550 amu	A wide range to capture the molecular ion (if present) and

all key fragments.

The EI mass spectrum of derivatized **pentedrone** is key to its identification. While the molecular ion may be weak or absent, characteristic fragment ions are consistently produced. For TFA-derivatized **pentedrone**, key fragments arise from the cleavage of the alkyl side chain. The most abundant fragment is often the immonium ion resulting from alpha-cleavage next to the nitrogen atom. Researchers should confirm the identity of a peak by comparing its retention time and mass spectrum to that of a certified reference standard analyzed under the same conditions.[17]

## Method Validation and Performance

Any analytical method used in a regulated environment must be validated to ensure its performance is reliable. Key validation parameters include linearity, limit of detection (LOD), limit of quantification (LOQ), precision, and accuracy.[4]

The following table presents a summary of reported validation data for **pentedrone** and related cathinones in various biological matrices, demonstrating the expected performance of a well-optimized GC-MS method.

Analyte	Matrix	Method	Linearity Range	LOD	LOQ	Source(s)
Pentadron e	Urine	PT-SPE- LC-MS/MS	0.5–100 ng/mL	0.100 ng/mL	0.500 ng/mL	[18]
N-Ethyl Pentadron e	Oral Fluid	LLE-GC- MS/MS	1.75-5000 ng/mL	0.5 ng/mL	1.75 ng/mL	[6]
Cathinones (general)	Whole Blood	SPE-GC- MS	25-800 ng/mL	5-25 ng/mL	25 ng/mL	[19]
Cathinones (general)	Urine	LLE-GC- MS	100-1000 ng/mL	10-30 ng/mL	30-100 ng/mL	[4]

## Conclusion

This application note provides a detailed and scientifically grounded protocol for the detection of **pentedrone** in biological matrices using GC-MS. By combining a robust sample preparation strategy—either LLE or SPE—with chemical derivatization and optimized instrumental parameters, laboratories can achieve the sensitivity and specificity required for confident identification and quantification. The causality-driven explanations for each step empower analysts to not only follow the protocol but also to troubleshoot and adapt it as needed, ensuring the generation of trustworthy and defensible results in the dynamic field of forensic and clinical toxicology.

## References

- Hamby, T. (2018, October 29). Comparison of Liquid-Liquid Extraction and Solid Phase Extraction of Mephedrone. Valdosta State University. Retrieved from [\[Link\]](#)
- Montanari, E., et al. (2023). GC–MS/MS Determination of Synthetic Cathinones: 4-chloromethcathinone, N-ethyl **Pentedrone**, and N-ethyl Hexedrone in Oral Fluid and Sweat of Consumers under Controlled Administration: Pilot Study. International Journal of Molecular Sciences, 24(11), 9348. [\[Link\]](#)
- Soares, J., et al. (2022). Enantioselectivity of **Pentedrone** and Methylone on Metabolic Profiling in 2D and 3D Human Hepatocyte-like Cells. International Journal of Molecular Sciences, 23(6), 3192. [\[Link\]](#)
- SWGDRUG.org. (2014, January 22). **Pentedrone**. SWGDRUG Monograph. Retrieved from [\[Link\]](#)
- Montanari, E., et al. (2023). GC-MS/MS Determination of Synthetic Cathinones: 4-chloromethcathinone, N-ethyl **Pentedrone**, and N-ethyl Hexedrone in Oral Fluid and Sweat of Consumers under Controlled Administration: Pilot Study. Semantic Scholar. Retrieved from [\[Link\]](#)
- The Center for Forensic Science Research & Education. (2020, February 24). N-Ethyl **Pentedrone**. CFSRE. Retrieved from [\[Link\]](#)
- ResearchGate. (n.d.). (a) is the mass spectrum of **pentedrone** and figure 4(b) is the mass.... Retrieved from [\[Link\]](#)

- Westphal, F., et al. (2012). Mass, NMR and IR spectroscopic characterization of **pentedrone** and pentylone and identification of their isocathinone by-products. *Forensic Science International*, 217(1-3), 157-67. Retrieved from [[Link](#)]
- SpectraBase. (n.d.). **Pentedrone** AC - Optional[MS (GC)] - Spectrum. Retrieved from [[Link](#)]
- Uralets, V., & Rana, S. (2014). Testing for designer stimulants: metabolic profiles of 16 synthetic cathinones excreted free in human urine. *Journal of analytical toxicology*, 38(5), 233–241. [[Link](#)]
- ResearchGate. (2023, May 27). (PDF) GC-MS/MS Determination of Synthetic Cathinones: 4-Chloromethcathinone, N-Ethyl **Pentedrone**, and N-Ethyl Hexedrone in Oral Fluid and Sweat of Consumers under Controlled Administration: Pilot Study. Retrieved from [[Link](#)]
- National Institute of Standards and Technology. (n.d.). Development and Evaluation of a Synthetic Cathinone Targeted Gas Chromatography Mass Spectrometry (GC-MS) Method. Retrieved from [[Link](#)]
- MDPI. (2022, September 1). Homemade Pipette Tip Solid-Phase Extraction for the Simultaneous Determination of 40 Drugs of Abuse in Urine by Liquid Chromatography–Tandem Mass Spectrometry. Retrieved from [[Link](#)]
- Alsenedi, K. A., & Morrison, C. (2017). Comparison of six derivatizing agents for the determination of nine synthetic cathinones using gas chromatography-mass spectrometry. *Analytical Methods*, 9(18), 2738-2748. [[Link](#)]
- ResearchGate. (2022, September). (PDF) Homemade Pipette Tip Solid-Phase Extraction for the Simultaneous Determination of 40 Drugs of Abuse in Urine by Liquid Chromatography–Tandem Mass Spectrometry. Retrieved from [[Link](#)]
- Barroso, M., et al. (2021). Determination of Selected Cathinones in Blood by Solid-Phase Extraction and GC-MS. *Journal of analytical toxicology*, 45(3), 233–242. [[Link](#)]
- Papaseit, E., et al. (2016). GC-MS QUANTIFICATION METHOD FOR MEPHEDRONE IN PLASMA AND URINE: APPLICATION TO HUMAN PHARMACOKINETICS. *Repositori UPF*. Retrieved from [[Link](#)]

- Giorgetti, A., et al. (2022). Determination of several synthetic cathinones and an amphetamine-like compound in urine by gas chromatography with mass. *Journal of Pharmaceutical and Biomedical Analysis*, 219, 114958. Retrieved from [\[Link\]](#)
- ResearchGate. (n.d.). (PDF) Development and validation of a GC–MS/MS method for the determination of 11 amphetamines and 34 synthetic cathinones in whole blood. Retrieved from [\[Link\]](#)
- Hasegawa, C. (2015). Application of solid-phase extraction tips for the analysis of drugs in human blood. *Journal of Forensic Research*. Retrieved from [\[Link\]](#)
- Asian Journal of Chemistry. (2024, August 30). GC-MS/MS-Based Detection and Quantification of Methamphetamine and Mephedrone in Biological Matrices using Modified dSPE Method. Retrieved from [\[Link\]](#)
- United Nations Office on Drugs and Crime. (n.d.). Recommended methods for the identification and analysis of synthetic cathinones in seized materials. Retrieved from [\[Link\]](#)
- iris univpm. (2023). Comparison of authentic urine N -ethyl**pentedrone** metabolites to predicted in silico and in vitro human hepatocyte metabolism. Retrieved from [\[Link\]](#)
- Raikos, N., et al. (2022). Development and Validation of a Single Step GC/MS Method for the Determination of 41 Drugs and Drugs of Abuse in Postmortem Blood. *Separations*, 9(7), 177. [\[Link\]](#)
- DeRienz, K. T., & Roper Miller, J. D. (2021). Development and Evaluation of a Synthetic Cathinone Targeted Gas Chromatography Mass Spectrometry (GC-MS) Method. *Journal of research of the National Institute of Standards and Technology*, 126, 126021. [\[Link\]](#)
- Royal Society of Chemistry. (2017, May 3). Comparison of six derivatizing agents for the determination of nine synthetic cathinones using gas chromatography-mass spectrometry. Retrieved from [\[Link\]](#)
- Papoutsis, I., et al. (2017). Simultaneous determination of 40 novel psychoactive stimulants in urine by liquid chromatography-high resolution mass spectrometry and library matching. *Journal of pharmaceutical and biomedical analysis*, 145, 146–155. [\[Link\]](#)

- ResearchGate. (2024). Applications of Sample Preparation Techniques in the Analysis of New Psychoactive Substances. Retrieved from [[Link](#)]

### Need Custom Synthesis?

BenchChem offers custom synthesis for rare earth carbides and specific isotopic labeling.

Email: [info@benchchem.com](mailto:info@benchchem.com) or [Request Quote Online](#).

## Sources

- 1. [cfsre.org](https://cfsre.org) [[cfsre.org](https://cfsre.org)]
- 2. [unodc.org](https://unodc.org) [[unodc.org](https://unodc.org)]
- 3. [tsapps.nist.gov](https://tsapps.nist.gov) [[tsapps.nist.gov](https://tsapps.nist.gov)]
- 4. [iris.unito.it](https://iris.unito.it) [[iris.unito.it](https://iris.unito.it)]
- 5. [mdpi.com](https://mdpi.com) [[mdpi.com](https://mdpi.com)]
- 6. [pmc.ncbi.nlm.nih.gov](https://pmc.ncbi.nlm.nih.gov) [[pmc.ncbi.nlm.nih.gov](https://pmc.ncbi.nlm.nih.gov)]
- 7. [researchgate.net](https://researchgate.net) [[researchgate.net](https://researchgate.net)]
- 8. Homemade Pipette Tip Solid-Phase Extraction for the Simultaneous Determination of 40 Drugs of Abuse in Urine by Liquid Chromatography–Tandem Mass Spectrometry [[mdpi.com](https://mdpi.com)]
- 9. Simultaneous determination of 40 novel psychoactive stimulants in urine by liquid chromatography-high resolution mass spectrometry and library matching - PMC [[pmc.ncbi.nlm.nih.gov](https://pmc.ncbi.nlm.nih.gov)]
- 10. "Comparison of Liquid-Liquid Extraction and Solid Phase Extraction of M" by Brittany Simone Love [[aquila.usm.edu](https://aquila.usm.edu)]
- 11. [hilarispublisher.com](https://hilarispublisher.com) [[hilarispublisher.com](https://hilarispublisher.com)]
- 12. Comparison of six derivatizing agents for the determination of nine synthetic cathinones using gas chromatography-mass spectrometry - Analytical Methods (RSC Publishing) DOI:10.1039/C7AY00597K [[pubs.rsc.org](https://pubs.rsc.org)]
- 13. Comparison of six derivatizing agents for the determination of nine synthetic cathinones using gas chromatography-mass spectrometry - Analytical Methods (RSC Publishing) [[pubs.rsc.org](https://pubs.rsc.org)]
- 14. Enantioselectivity of Pentedrone and Methydone on Metabolic Profiling in 2D and 3D Human Hepatocyte-like Cells - PMC [[pmc.ncbi.nlm.nih.gov](https://pmc.ncbi.nlm.nih.gov)]

- [15. semanticscholar.org \[semanticscholar.org\]](#)
- [16. swgdrug.org \[swgdrug.org\]](#)
- [17. researchgate.net \[researchgate.net\]](#)
- [18. researchgate.net \[researchgate.net\]](#)
- [19. Determination of Selected Cathinones in Blood by Solid-Phase Extraction and GC-MS - PubMed \[pubmed.ncbi.nlm.nih.gov\]](#)
- To cite this document: BenchChem. [GC-MS parameters for detecting pentedrone in biological matrices]. BenchChem, [2026]. [Online PDF]. Available at: [\[https://www.benchchem.com/product/b609907/docs#gc-ms-parameters-for-detecting-pentedrone-in-biological-matrices\]](https://www.benchchem.com/product/b609907/docs#gc-ms-parameters-for-detecting-pentedrone-in-biological-matrices)

---

### Disclaimer & Data Validity:

The information provided in this document is for Research Use Only (RUO) and is strictly not intended for diagnostic or therapeutic procedures. While BenchChem strives to provide accurate protocols, we make no warranties, express or implied, regarding the fitness of this product for every specific experimental setup.

**Technical Support:** The protocols provided are for reference purposes. Unsure if this reagent suits your experiment?

**Need Industrial/Bulk Grade?** [Request Custom Synthesis Quote](#)

## BenchChem

Our mission is to be the trusted global source of essential and advanced chemicals, empowering scientists and researchers to drive progress in science and industry.

### Contact

Address: 3281 E Guasti Rd

Ontario, CA 91761, United States

Phone: (601) 213-4426

Email: [info@benchchem.com](mailto:info@benchchem.com)

Contact our Ph.D. Support Team for a compatibility check