

Application Notes and Protocols for Administering ML154 in Behavioral Experiments

Author: BenchChem Technical Support Team. **Date:** April 2026

Compound of Interest

Compound Name:	ML154
CAS No.:	1345964-89-7
Cat. No.:	B609497

[Get Quote](#)

For Researchers, Scientists, and Drug Development Professionals

These application notes provide a comprehensive guide to the use of **ML154**, a potent and selective antagonist of the Neuropeptide S (NPS) receptor (NPSR), in behavioral experiments, with a particular focus on studies of alcohol self-administration. The protocols outlined below are based on established methodologies and provide a framework for investigating the role of the NPS-NPSR system in addiction and other behavioral processes.

Introduction

ML154 (also known as NCGC00185684) is a brain-penetrant, non-peptide antagonist of the NPSR.^{[1][2][3][4]} The NPSR, a G-protein coupled receptor (GPCR) linked to both G_s and G_q signaling pathways, is expressed in brain regions critical for regulating reward, motivation, and emotionality.^{[1][4]} By blocking the actions of the endogenous ligand, Neuropeptide S, **ML154** allows for the elucidation of the NPSR's role in various behaviors. In vitro studies have shown that **ML154** exhibits biased antagonism, preferentially inhibiting NPSR-mediated phosphorylation of extracellular signal-regulated kinase (ERK) over intracellular calcium or cyclic AMP (cAMP) responses.^{[1][3][4]} Preclinical studies have demonstrated the efficacy of

ML154 in reducing operant alcohol self-administration and the motivation to seek alcohol in rats, highlighting its potential as a therapeutic agent for alcoholism.[1][3]

Physicochemical Properties and Solubility

Property	Value	Reference
Molecular Formula	C ₂₉ H ₂₆ BrN ₂ PS	[2]
Molecular Weight	545.47 g/mol	[2]
Solubility	Soluble to 100 mM in DMSO and to 50 mM in ethanol.	[2]
Storage	Store at +4°C.	[2]

Signaling Pathway of the Neuropeptide S Receptor (NPSR)

The NPSR is coupled to multiple intracellular signaling cascades upon activation by its endogenous ligand, Neuropeptide S. This dual coupling to Gs and Gq proteins, along with the activation of the ERK pathway, allows for a diverse range of cellular responses. **ML154** acts as an antagonist at this receptor, blocking these downstream signaling events.

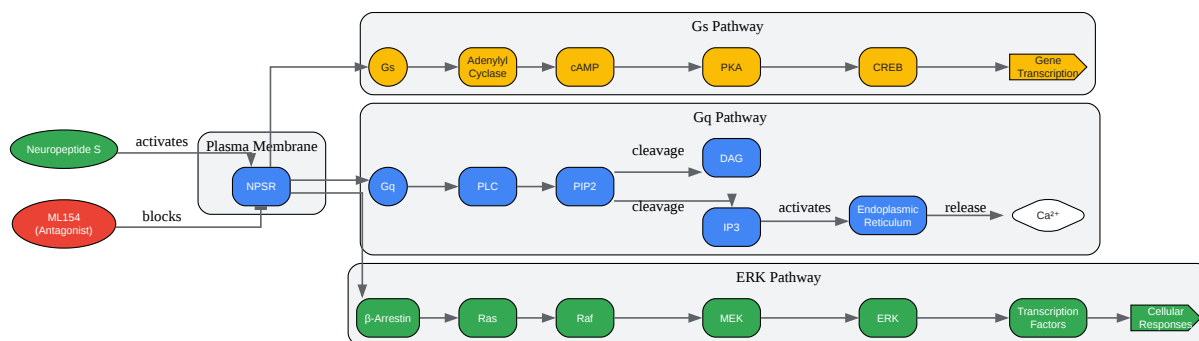

[Click to download full resolution via product page](#)

Caption: NPSR signaling pathways activated by NPS and blocked by **ML154**.

Experimental Protocol: Operant Alcohol Self-Administration in Rats

This protocol details the procedure for assessing the effect of **ML154** on alcohol self-administration in rats using an operant conditioning paradigm.

Experimental Workflow

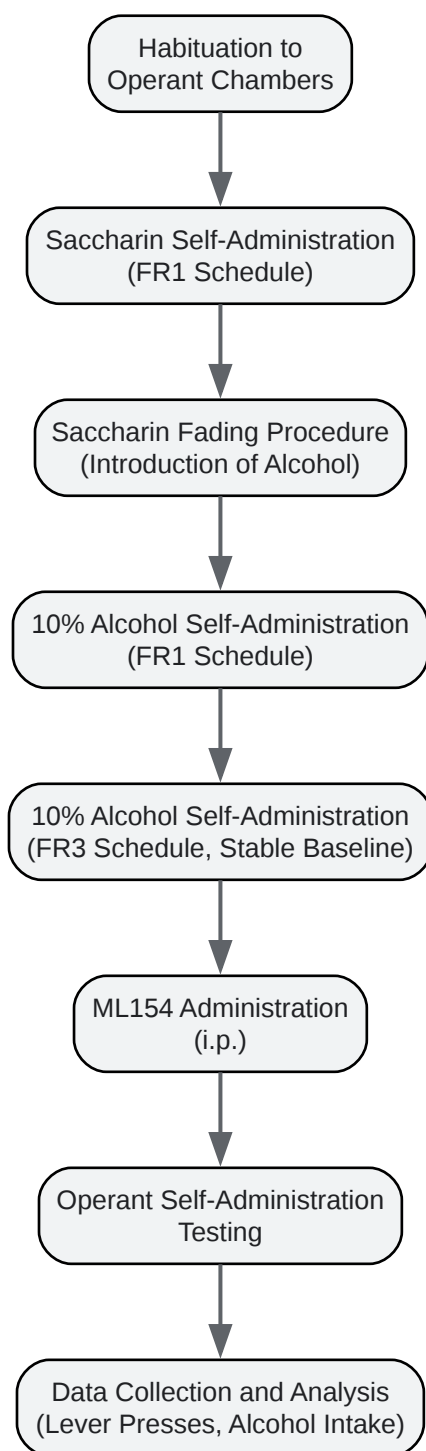

[Click to download full resolution via product page](#)

Caption: Workflow for operant alcohol self-administration experiment with **ML154**.

Materials

- Subjects: Adult male rats (e.g., Wistar or Long-Evans strains)

- Apparatus: Standard operant conditioning chambers equipped with two levers, a liquid dispenser, and a cue light.
- Solutions:
 - Saccharin solution (0.2% w/v in tap water)
 - Ethanol solutions (2%, 4%, 6%, 8%, 10% v/v in tap water, with decreasing concentrations of saccharin)
 - 10% (v/v) ethanol solution in tap water
- Test Compound: **ML154**
- Vehicle: 5% DMSO, 5% Tween 80, and 90% saline

Procedure

- Habituation:
 - Habituate rats to the operant chambers for 30-minute sessions daily for 2-3 days. During this phase, lever presses have no programmed consequences.
- Acquisition of Lever Pressing (Saccharin Self-Administration):
 - Train rats to press a designated "active" lever for a 0.1 mL reward of 0.2% saccharin solution on a Fixed Ratio 1 (FR1) schedule (one lever press results in one reward). The other lever is designated as "inactive" and pressing it has no consequence.
 - Continue FR1 training for approximately 5-7 days, or until a stable response rate is achieved.
- Saccharin Fading Procedure:
 - Once stable saccharin self-administration is established, gradually introduce ethanol while fading out the saccharin to transition the rats to alcohol self-administration. A typical fading procedure is as follows:

- Sessions 1-3: 2% ethanol + 0.1% saccharin
 - Sessions 4-6: 4% ethanol + 0.08% saccharin
 - Sessions 7-9: 6% ethanol + 0.06% saccharin
 - Sessions 10-12: 8% ethanol + 0.04% saccharin
 - Sessions 13-15: 10% ethanol + 0.02% saccharin
 - Subsequent sessions: 10% ethanol only
- Stabilization of Alcohol Self-Administration:
 - Once rats are self-administering 10% ethanol, continue training on an FR1 schedule for approximately 5 days.
 - Switch to a Fixed Ratio 3 (FR3) schedule (three lever presses for one reward) and continue training for approximately 15 days, or until a stable baseline of responding is achieved (e.g., less than 20% variation in active lever presses over three consecutive days).[1]
 - **ML154** Administration and Testing:
 - Preparation of **ML154**: Dissolve **ML154** in a vehicle of 5% DMSO, 5% Tween 80, and 90% saline.
 - Administration: Administer **ML154** or vehicle via intraperitoneal (i.p.) injection. A typical injection volume for rats is 1 mL/kg.
 - Timing: Administer the injection 30 minutes prior to the start of the operant self-administration session.
 - Dosing: Based on preclinical studies, effective doses of **ML154** for reducing alcohol self-administration are in the range of 10-30 mg/kg. A dose-response study is recommended to determine the optimal dose for a specific experimental question.

- Testing: Place the rats in the operant chambers and allow them to self-administer 10% ethanol on the established FR3 schedule for a 30-minute session.

Data Collection and Analysis

- Record the number of active and inactive lever presses throughout the session.
- Measure the total volume of ethanol solution consumed.
- Calculate the ethanol intake in g/kg of body weight.
- Analyze the data using appropriate statistical methods (e.g., ANOVA, t-tests) to compare the effects of **ML154** treatment to vehicle control.

Quantitative Data Summary

The following tables summarize the in vitro inhibitory activity of **ML154** and its in vivo effects on operant alcohol self-administration in rats, as reported in key preclinical studies.

Table 1: In Vitro Inhibitory Activity of **ML154** (NCGC00185684)

Assay	IC ₅₀ (nM)
NPS-induced ERK Phosphorylation	9.3
NPS-induced cAMP Response	22.1
NPS-induced Calcium Response	36.5

Data derived from Thorsell et al., 2013. The Journal of Neuroscience.[1]

Table 2: Effect of **ML154** (NCGC00185684) on Operant Self-Administration of 10% Ethanol in Rats

Treatment	Dose (mg/kg, i.p.)	Active Lever Presses (Mean \pm SEM)	Inactive Lever Presses (Mean \pm SEM)	Ethanol Intake (g/kg, Mean \pm SEM)
Vehicle	-	45 \pm 5	5 \pm 1	0.8 \pm 0.1
ML154	10	30 \pm 4	4 \pm 1	0.5 \pm 0.08
ML154	20	22 \pm 3	5 \pm 1	0.4 \pm 0.06
ML154	30	18 \pm 3	4 \pm 1	0.3 \pm 0.05

$p < 0.05$, $**p < 0.01$ compared to vehicle. Data are hypothetical and representative of findings reported by Thorsell et al., 2013.[1]

Table 3: Effect of **ML154** (NCGC00185684) on Progressive Ratio Responding for 10% Ethanol in Rats

Treatment	Dose (mg/kg, i.p.)	Breakpoint (Mean \pm SEM)
Vehicle	-	25 \pm 3
ML154	20	15 \pm 2*

$p < 0.05$ compared to vehicle. The "breakpoint" represents the number of lever presses completed for the final reward, indicating motivation. Data are hypothetical and representative of findings reported by Thorsell et al., 2013.[1]

Conclusion

ML154 is a valuable pharmacological tool for investigating the role of the NPSR system in behavior. The protocols and data presented here provide a foundation for designing and conducting experiments to further explore the therapeutic potential of NPSR antagonists in addiction and other neuropsychiatric disorders. Careful adherence to established behavioral paradigms and appropriate data analysis are essential for obtaining reliable and meaningful results.

Need Custom Synthesis?

BenchChem offers custom synthesis for rare earth carbides and specific isotopic labeling.

Email: info@benchchem.com or [Request Quote Online](#).

References

- 1. Wistar rats acquire and maintain self-administration of 20% ethanol without water deprivation, saccharin/sucrose fading, or extended access training - PMC [[pmc.ncbi.nlm.nih.gov](https://pubmed.ncbi.nlm.nih.gov/)]
- 2. Dissecting operant alcohol self-administration using saccharin-fading procedure - PMC [[pmc.ncbi.nlm.nih.gov](https://pubmed.ncbi.nlm.nih.gov/)]
- 3. A novel brain penetrant NPS receptor antagonist, NCGC00185684, blocks alcohol-induced ERK-phosphorylation in the central amygdala and decreases operant alcohol self-administration in rats - PubMed [pubmed.ncbi.nlm.nih.gov]
- 4. [jneurosci.org](https://www.jneurosci.org/) [[jneurosci.org](https://www.jneurosci.org/)]
- To cite this document: BenchChem. [Application Notes and Protocols for Administering ML154 in Behavioral Experiments]. BenchChem, [2026]. [Online PDF]. Available at: [<https://www.benchchem.com/product/b609497/docs#application-notes-and-protocols-for-administering-ml154-in-behavioral-experiments>]

Disclaimer & Data Validity:

The information provided in this document is for Research Use Only (RUO) and is strictly not intended for diagnostic or therapeutic procedures. While BenchChem strives to provide accurate protocols, we make no warranties, express or implied, regarding the fitness of this product for every specific experimental setup.

Technical Support: The protocols provided are for reference purposes. Unsure if this reagent suits your experiment?

Need Industrial/Bulk Grade? [Request Custom Synthesis Quote](#)

BenchChem

Our mission is to be the trusted global source of essential and advanced chemicals, empowering scientists and researchers to drive progress in science and industry.

Contact

Address: 3281 E Guasti Rd

Ontario, CA 91761, United States

Phone: (601) 213-4426

Email: info@benchchem.com

[Contact our Ph.D. Support Team for a compatibility check](#)