

Application Notes: Immunohistochemical Localization of the 5-HT4 Receptor

Author: BenchChem Technical Support Team. **Date:** April 2026

Compound of Interest

Compound Name: PF-03382792

CAS No.: 1400811-63-3

Cat. No.: B609921

[Get Quote](#)

These application notes provide a comprehensive guide for the detection and localization of the 5-hydroxytryptamine receptor 4 (5-HT4R) in tissue samples using immunohistochemistry (IHC). This document is intended for researchers, scientists, and drug development professionals.

Introduction

The 5-HT4 receptor, a member of the G-protein coupled receptor (GPCR) family, is a key modulator in various physiological processes.[1] Primarily coupled to Gas proteins, its activation stimulates adenylyl cyclase, leading to an increase in intracellular cyclic AMP (cAMP) and subsequent activation of Protein Kinase A (PKA).[2][3] The 5-HT4 receptor is also capable of G-protein independent signaling through the activation of Src tyrosine kinase, which in turn activates the extracellular signal-regulated kinase (ERK) pathway.[4][5] Dysregulation of 5-HT4 receptor signaling has been implicated in neuropsychiatric conditions such as depression and Alzheimer's disease, as well as gastrointestinal disorders.[2] Consequently, understanding its precise tissue and cellular distribution is crucial for both basic research and therapeutic development.

Tissue Distribution of the 5-HT4 Receptor

The 5-HT4 receptor exhibits a wide but distinct distribution throughout the body. In the central nervous system (CNS), high levels of expression are observed in the basal ganglia (putamen, caudate nucleus, nucleus accumbens, globus pallidus, and substantia nigra) and the hippocampal formation.[1][6] Lower levels are found in the neocortex, raphe nuclei, and parts of the thalamus.[6] Peripherally, the 5-HT4 receptor is prominently located in the gastrointestinal tract, urinary bladder, heart, and adrenal glands.[1][6] The expression of different splice variants of the 5-HT4 receptor can vary between tissues.[7][8]

Table 1: Quantitative Summary of 5-HT4 Receptor Expression

Tissue/Region	Expression Level	Key Splice Variants Detected	Reference
Central Nervous System			
Basal Ganglia	High	a, b, c, g, n, i	[1][6][7]
Hippocampus	High	a, b, c, g, n, i	[1][7]
Neocortex	Low to Moderate	a, b, c, g, n, i	[6][7]
Peripheral Tissues			
Gastrointestinal Tract	High	a, b, c, d, g, e, f, i	[1][7][8]
Heart (Atrium & Ventricle)	Moderate	a, b, c, g, n, i	[6][7]
Urinary Bladder	Moderate	a	[6][7]
Adrenal Gland	Moderate	a, b (normal), d (adenomas)	[6][7]

Signaling Pathways of the 5-HT4 Receptor

The 5-HT4 receptor activates downstream signaling through two primary pathways:

- **Canonical G α s-cAMP Pathway:** Upon serotonin binding, the receptor activates the G α s subunit of the G-protein complex. This stimulates adenylyl cyclase to produce cAMP, which

in turn activates PKA. PKA can then phosphorylate various downstream targets, including transcription factors like CREB.[2][9]

- Non-Canonical Src/ERK Pathway: The 5-HT4 receptor can also signal independently of G-proteins by directly activating the Src tyrosine kinase.[4] Activated Src can then phosphorylate and activate the ERK/MAPK pathway, which is also implicated in learning and memory processes.[4][5]

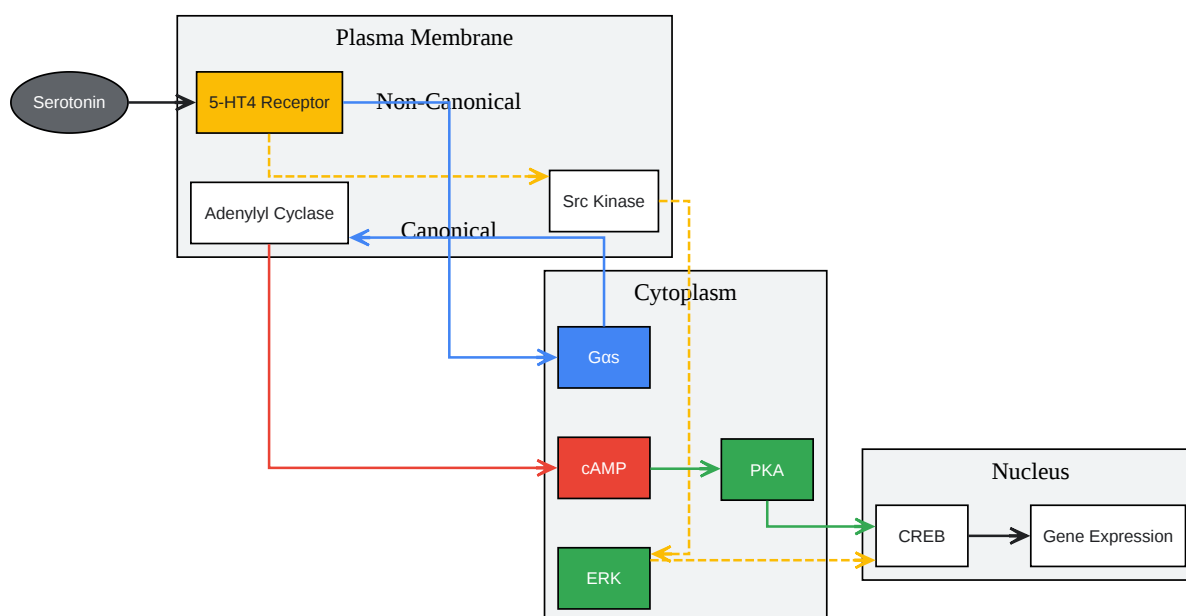

[Click to download full resolution via product page](#)

5-HT4 Receptor Signaling Pathways

Experimental Protocols

Antibody Selection and Validation

The success of IHC for the 5-HT4 receptor is highly dependent on the quality and specificity of the primary antibody. Several commercial antibodies are available. It is crucial to select an antibody that has been validated for IHC in the species of interest.

Table 2: Commercially Available 5-HT4 Receptor Antibodies for IHC

Vendor	Catalog Number	Type	Host	Validated Species	Recommended Dilution (IHC-P)
Abcam	ab219116	Polyclonal	Rabbit	Human	Not specified
Thermo Fisher	BS-2127R	Polyclonal	Rabbit	Human, Mouse, Rat	1:400
R&D Systems	MAB6545	Monoclonal	Mouse	Human	15 µg/mL
ImmunoStar	20080	Polyclonal	Rabbit	Mouse, Danio rerio	1:200 - 1:10,000

Note: The optimal dilution for each antibody should be determined empirically by the end-user.

Immunohistochemistry Protocol for Paraffin-Embedded Sections

This protocol provides a general guideline for the immunohistochemical staining of 5-HT4 receptors in formalin-fixed, paraffin-embedded (FFPE) tissue sections.

Materials:

- FFPE tissue sections (4-5 µm) on charged slides
- Xylene
- Ethanol (100%, 95%, 85%, 75%, 70%)
- Deionized water

- Antigen retrieval buffer (e.g., 10 mM Sodium Citrate, pH 6.0)
- Hydrogen peroxide (3%)
- Blocking buffer (e.g., 10% normal goat serum in PBS)
- Primary antibody against 5-HT4 receptor
- Biotinylated secondary antibody
- Streptavidin-HRP conjugate
- DAB (3,3'-Diaminobenzidine) substrate kit
- Hematoxylin counterstain
- Mounting medium

Procedure:

- Deparaffinization and Rehydration:
 - Incubate slides in xylene: 2 x 5 minutes.
 - Incubate in 100% ethanol: 2 x 3 minutes.
 - Incubate in 95% ethanol: 2 x 3 minutes.
 - Incubate in 70% ethanol: 2 x 3 minutes.
 - Rinse with deionized water.
- Antigen Retrieval:
 - Immerse slides in pre-heated antigen retrieval buffer.
 - Heat in a microwave, pressure cooker, or water bath. For example, microwave at high power for 5 minutes, then medium-high power for 10 minutes.[\[10\]](#)

- Allow slides to cool in the buffer for 20-30 minutes at room temperature.
- Rinse with PBS (3 x 5 minutes).
- Peroxidase Blocking:
 - Incubate sections with 3% hydrogen peroxide in methanol for 10-20 minutes to block endogenous peroxidase activity.[\[11\]](#)[\[12\]](#)
 - Rinse with PBS (3 x 5 minutes).
- Blocking:
 - Incubate sections with blocking buffer for 1 hour at room temperature to prevent non-specific antibody binding.[\[13\]](#)
- Primary Antibody Incubation:
 - Dilute the primary 5-HT4R antibody in blocking buffer to the predetermined optimal concentration.
 - Incubate sections with the primary antibody overnight at 4°C in a humidified chamber.
- Secondary Antibody Incubation:
 - Rinse slides with PBS (3 x 5 minutes).
 - Incubate with a biotinylated secondary antibody (e.g., goat anti-rabbit or goat anti-mouse) for 1 hour at room temperature.
- Signal Amplification:
 - Rinse slides with PBS (3 x 5 minutes).
 - Incubate with Streptavidin-HRP conjugate for 30 minutes at room temperature.
- Chromogenic Detection:
 - Rinse slides with PBS (3 x 5 minutes).

- Incubate with DAB substrate solution until the desired brown color develops (typically 1-10 minutes). Monitor under a microscope.
- Stop the reaction by rinsing with deionized water.
- Counterstaining:
 - Counterstain with hematoxylin for 1-2 minutes.
 - "Blue" the sections in running tap water.
- Dehydration and Mounting:
 - Dehydrate the sections through graded alcohols (70%, 95%, 100%).
 - Clear in xylene.
 - Coverslip with a permanent mounting medium.

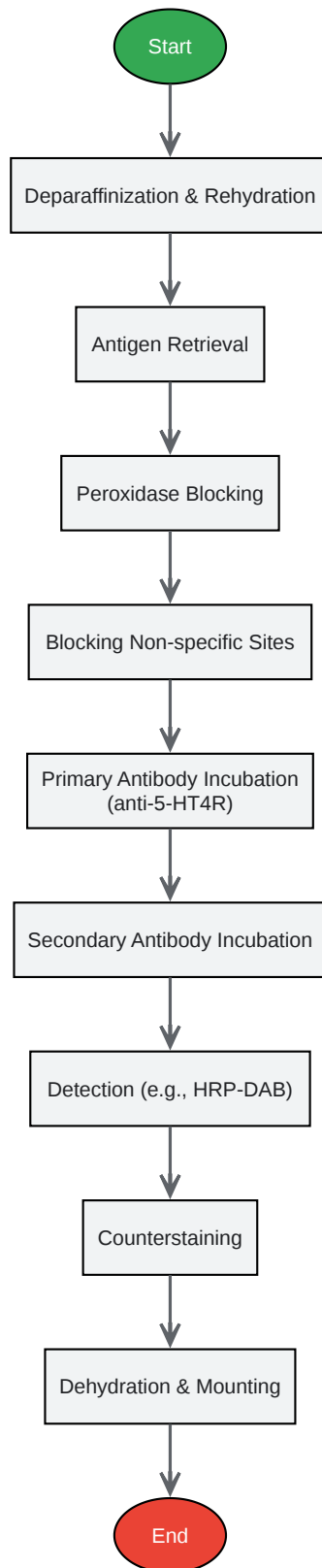

[Click to download full resolution via product page](#)

Immunohistochemistry Workflow

Data Interpretation and Controls

- **Positive Control:** A tissue known to express the 5-HT4 receptor (e.g., colon or hippocampus) should be included in each experiment to validate the staining procedure.
- **Negative Control:** A slide incubated with the antibody diluent instead of the primary antibody should be processed to assess non-specific staining from the secondary antibody and detection reagents.
- **Localization:** Staining for the 5-HT4 receptor is expected to be localized to the plasma membrane of positive cells.^[4]

Troubleshooting

Table 3: Common IHC Problems and Solutions

Problem	Possible Cause	Suggested Solution
No Staining	Inactive primary antibody	Use a new or different validated antibody.
Incorrect antibody dilution	Optimize antibody concentration through titration.	
Inadequate antigen retrieval	Optimize antigen retrieval method (time, temperature, buffer pH).	
High Background	Non-specific antibody binding	Increase blocking time or use a different blocking reagent.
Endogenous peroxidase activity	Ensure complete peroxidase blocking.	
Too high primary antibody concentration	Further dilute the primary antibody.	
Non-specific Staining	Cross-reactivity of secondary antibody	Use a secondary antibody raised against the host of the primary antibody.
Tissue drying out during incubation	Use a humidified chamber for incubations.	

By following these application notes and protocols, researchers can achieve reliable and reproducible immunohistochemical localization of the 5-HT4 receptor, contributing to a better understanding of its role in health and disease.

Need Custom Synthesis?

BenchChem offers custom synthesis for rare earth carbides and specific isotopic labeling.

Email: info@benchchem.com or [Request Quote Online](#).

References

- [1. mdpi.com \[mdpi.com\]](https://www.mdpi.com)
- [2. researchgate.net \[researchgate.net\]](https://www.researchgate.net)
- [3. What are 5-HT4 receptor agonists and how do they work? \[synapse.patsnap.com\]](https://synapse.patsnap.com)
- [4. 5-hydroxytryptamine 4 receptor activation of the extracellular signal-regulated kinase pathway depends on Src activation but not on G protein or beta-arrestin signaling - PubMed \[pubmed.ncbi.nlm.nih.gov\]](https://pubmed.ncbi.nlm.nih.gov)
- [5. researchgate.net \[researchgate.net\]](https://www.researchgate.net)
- [6. 5-HT4 receptor - Wikipedia \[en.wikipedia.org\]](https://en.wikipedia.org)
- [7. Human 5-HT4 and 5-HT7 Receptor Splice Variants: Are they Important? - PMC \[pmc.ncbi.nlm.nih.gov\]](https://pmc.ncbi.nlm.nih.gov)
- [8. jnmjournal.org \[jnmjournal.org\]](https://www.jnmjournal.org)
- [9. researchgate.net \[researchgate.net\]](https://www.researchgate.net)
- [10. bosterbio.com \[bosterbio.com\]](https://www.bosterbio.com)
- [11. cancer.wisc.edu \[cancer.wisc.edu\]](https://cancer.wisc.edu)
- [12. Immunohistochemistry Protocols | Thermo Fisher Scientific - HK \[thermofisher.com\]](https://www.thermofisher.com)
- [13. jpatholm.org \[jpatholm.org\]](https://www.jpatholm.org)
- To cite this document: BenchChem. [Application Notes: Immunohistochemical Localization of the 5-HT4 Receptor]. BenchChem, [2026]. [Online PDF]. Available at: [\[https://www.benchchem.com/product/b609921/docs#application-notes-immunohistochemical-localization-of-the-5-ht4-receptor\]](https://www.benchchem.com/product/b609921/docs#application-notes-immunohistochemical-localization-of-the-5-ht4-receptor)

Disclaimer & Data Validity:

The information provided in this document is for Research Use Only (RUO) and is strictly not intended for diagnostic or therapeutic procedures. While BenchChem strives to provide accurate protocols, we make no warranties, express or implied, regarding the fitness of this product for every specific experimental setup.

Technical Support: The protocols provided are for reference purposes. Unsure if this reagent suits your experiment?

Need Industrial/Bulk Grade? [Request Custom Synthesis Quote](#)

BenchChem

Our mission is to be the trusted global source of essential and advanced chemicals, empowering scientists and researchers to drive progress in science and industry.

Contact

Address: 3281 E Guasti Rd

Ontario, CA 91761, United States

Phone: (601) 213-4426

Email: info@benchchem.com

[Contact our Ph.D. Support Team for a compatibility check](#)