

Application Note: PF-04531083 Dissolution for Cell Culture

Author: BenchChem Technical Support Team. **Date:** April 2026

Compound of Interest

Compound Name: PF 04531083

CAS No.: 1079400-07-9

Cat. No.: B609928

[Get Quote](#)

Introduction

PF-04531083 is a potent and selective blocker of the voltage-gated sodium channel NaV1.8.[1][2] This channel is primarily expressed in the peripheral nervous system, particularly in nociceptive neurons of the dorsal root ganglion (DRG), and plays a crucial role in pain signaling.[3][4] Due to its specificity, PF-04531083 is a valuable tool for research into neuropathic and inflammatory pain.[1][2] It is an orally active, blood-brain barrier penetrant compound, which also makes it relevant for CNS-related studies.[2][5][6] Proper dissolution and handling are critical for obtaining reliable and reproducible results in cell culture experiments. This document provides a detailed protocol for the dissolution of PF-04531083 for use in in vitro studies.

Mechanism of Action

Voltage-gated sodium channels (NaVs) are essential for the initiation and propagation of action potentials in excitable cells.[4] The NaV1.8 subtype, encoded by the SCN10A gene, is characterized by its resistance to tetrodotoxin (TTX) and its distinct biophysical properties, including slower inactivation kinetics, which contribute to cellular hyperexcitability in nociceptive

neurons.[3] PF-04531083 selectively inhibits the NaV1.8 channel, thereby reducing the influx of sodium ions and dampening neuronal excitability. This targeted action makes it a subject of interest for investigating pain pathways and other neurological conditions where NaV1.8 may be dysregulated.[4][5]

Data and Properties

The following tables summarize the key quantitative data for PF-04531083.

Table 1: Chemical Properties

Property	Value
Molecular Weight	357.79 g/mol
Chemical Formula	C ₁₇ H ₁₆ F ₃ N ₅ O
CAS Number	1079400-07-9

Table 2: Solubility Data

Solvent	Concentration	Notes
Dimethyl Sulfoxide (DMSO)	120 mg/mL (approx. 335 mM) [1]	Sonication is recommended[1]
10% DMSO + 40% PEG300 + 5% Tween 80 + 45% Saline	4 mg/mL (approx. 11.18 mM) [1]	For in vivo formulation[1]

Table 3: Recommended Storage Conditions

Form	Storage Temperature	Shelf Life
Powder	-20°C	3 years[1]
In DMSO	-80°C	1 year[1]

Experimental Protocols

This section provides a detailed methodology for preparing PF-04531083 solutions for typical cell culture applications.

Materials:

- PF-04531083 powder
- Anhydrous/Sterile Dimethyl Sulfoxide (DMSO)
- Sterile microcentrifuge tubes or vials
- Vortex mixer
- Sonicator (optional, but recommended)
- Sterile, complete cell culture medium appropriate for your cell line
- Pipettes and sterile, filtered pipette tips

Protocol 1: Preparation of a Concentrated Stock Solution (e.g., 10 mM)

It is standard practice to prepare a highly concentrated stock solution, which can then be diluted to the final working concentration in the cell culture medium. This minimizes the final concentration of the solvent (DMSO) in the culture, which can be toxic to cells at higher concentrations (typically >0.5%).

- Calculate the required mass: To prepare 1 mL of a 10 mM stock solution, use the following calculation:
 - $\text{Volume (L)} \times \text{Concentration (mol/L)} \times \text{Molecular Weight (g/mol)} = \text{Mass (g)}$
 - $0.001 \text{ L} \times 0.01 \text{ mol/L} \times 357.79 \text{ g/mol} = 0.003578 \text{ g} = 3.58 \text{ mg}$
 - Therefore, weigh out approximately 3.58 mg of PF-04531083 powder.
- Dissolution:
 - Aseptically add the weighed powder to a sterile microcentrifuge tube.

- Add 1 mL of sterile DMSO to the tube.
- Cap the tube tightly and vortex thoroughly for 1-2 minutes to dissolve the compound.
- Sonication (Recommended):
 - If the solution is not completely clear, sonicate the vial in a water bath for 5-10 minutes to ensure complete dissolution.[1]
- Sterilization (Optional):
 - If necessary, the concentrated stock solution can be sterilized by passing it through a 0.22 μm syringe filter compatible with DMSO.
- Aliquoting and Storage:
 - Aliquot the stock solution into smaller, single-use volumes in sterile microcentrifuge tubes. This prevents repeated freeze-thaw cycles which can degrade the compound.
 - Store the aliquots at -80°C for up to one year.[1]

Protocol 2: Preparation of Working Solutions for Cell Treatment

The final working concentration of PF-04531083 will depend on the specific experiment and cell type. The IC_{50} for human NaV1.8 is approximately $0.7 \mu\text{M}$. [2] A typical starting point for experiments might be in the range of 0.1 to $10 \mu\text{M}$.

- Thaw the Stock Solution:
 - Remove one aliquot of the 10 mM stock solution from the -80°C freezer and thaw it at room temperature.
- Serial Dilution (if necessary):
 - It is recommended to perform an intermediate dilution of the stock solution in sterile cell culture medium or a buffered salt solution (e.g., PBS) before adding it to the final cell culture. This helps ensure a more uniform mixture.

- Final Dilution:
 - Add the appropriate volume of the stock solution to your pre-warmed, complete cell culture medium to achieve the desired final concentration. For example, to prepare 1 mL of medium with a final concentration of 1 μ M PF-04531083:
 - Use the formula: $C_1V_1 = C_2V_2$
 - $(10,000 \mu\text{M}) \times V_1 = (1 \mu\text{M}) \times (1000 \mu\text{L})$
 - $V_1 = 0.1 \mu\text{L}$
 - Add 0.1 μ L of the 10 mM stock solution to 1 mL of cell culture medium.
 - Important: The final concentration of DMSO should be kept as low as possible (ideally $\leq 0.1\%$). In this example, the final DMSO concentration is 0.01%. Always include a vehicle control (medium with the same final concentration of DMSO) in your experiments.
- Application to Cells:
 - Mix the medium containing PF-04531083 gently but thoroughly by pipetting.
 - Remove the existing medium from your cell culture plates and replace it with the treatment medium.

Visualizations

The following diagrams illustrate the experimental workflow and the mechanism of action of PF-04531083.

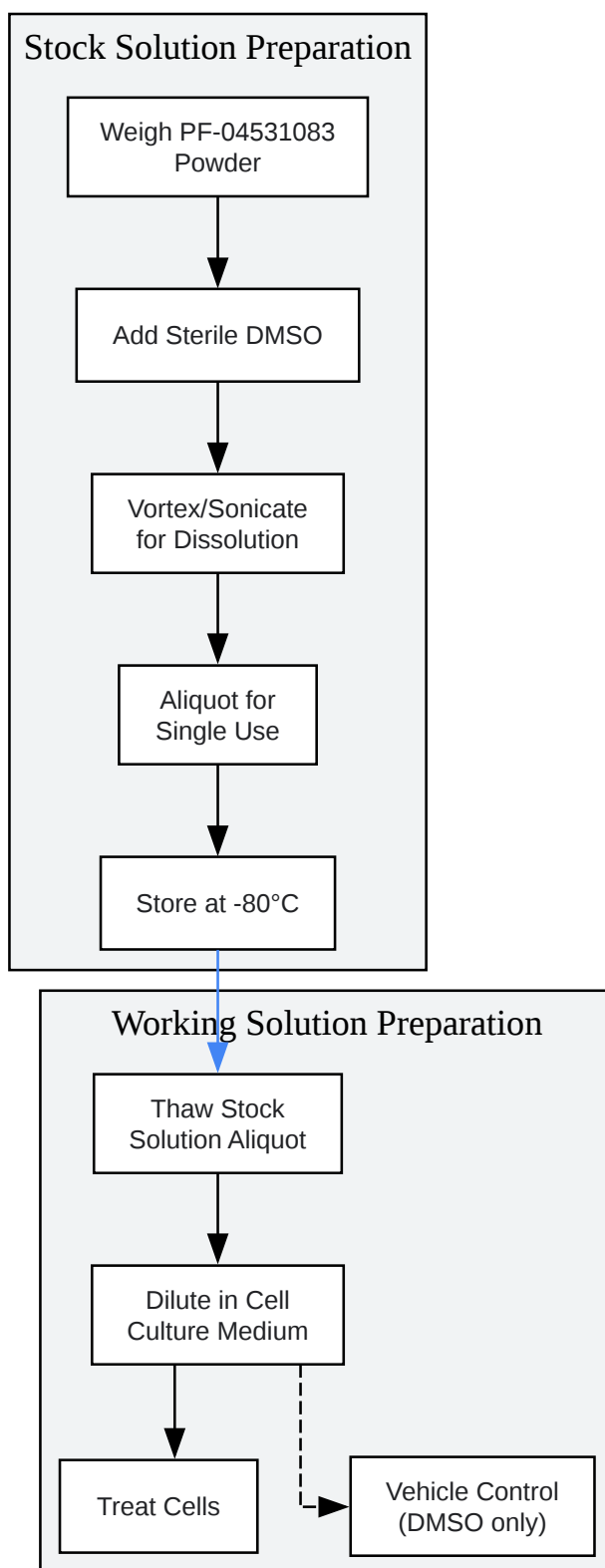

[Click to download full resolution via product page](#)

Caption: Workflow for preparing PF-04531083 solutions.

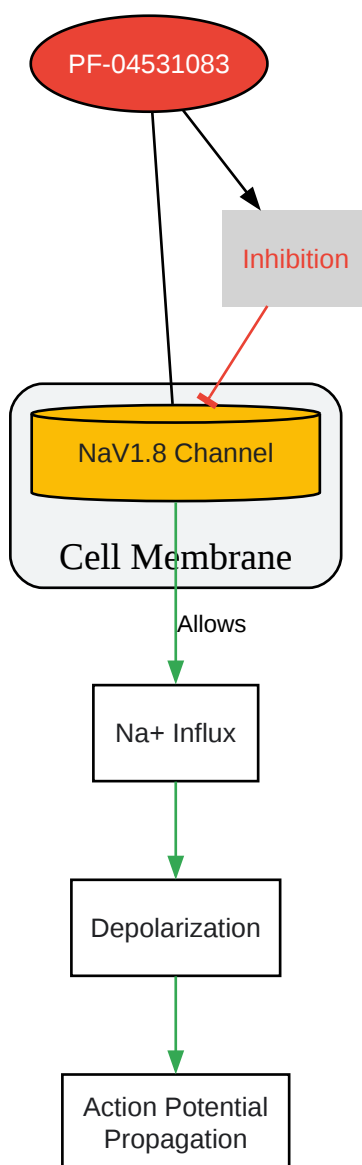

[Click to download full resolution via product page](#)

Caption: Mechanism of action of PF-04531083.

Need Custom Synthesis?

BenchChem offers custom synthesis for rare earth carbides and specific isotopic labeling.

Email: info@benchchem.com or [Request Quote Online](#).

References

- 1. PF 04531083 | Sodium Channel | TargetMol [[targetmol.com](https://www.targetmol.com)]
- 2. [medchemexpress.com](https://www.medchemexpress.com) [[medchemexpress.com](https://www.medchemexpress.com)]
- 3. Insights into the voltage-gated sodium channel, Nav1.8, and its role in visceral pain perception - PMC [[pmc.ncbi.nlm.nih.gov](https://pubmed.ncbi.nlm.nih.gov)]
- 4. Discovery and Optimization of Selective Nav1.8 Modulator Series That Demonstrate Efficacy in Preclinical Models of Pain - PMC [[pmc.ncbi.nlm.nih.gov](https://pubmed.ncbi.nlm.nih.gov)]
- 5. Evaluation of Nav1.8 as a therapeutic target for Pitt Hopkins Syndrome - PMC [[pmc.ncbi.nlm.nih.gov](https://pubmed.ncbi.nlm.nih.gov)]
- 6. [medchemexpress.com](https://www.medchemexpress.com) [[medchemexpress.com](https://www.medchemexpress.com)]
- To cite this document: BenchChem. [Application Note: PF-04531083 Dissolution for Cell Culture]. BenchChem, [2026]. [Online PDF]. Available at: [<https://www.benchchem.com/product/b609928/docs#application-note-pf-04531083-dissolution-for-cell-culture>]

Disclaimer & Data Validity:

The information provided in this document is for Research Use Only (RUO) and is strictly not intended for diagnostic or therapeutic procedures. While BenchChem strives to provide accurate protocols, we make no warranties, express or implied, regarding the fitness of this product for every specific experimental setup.

Technical Support: The protocols provided are for reference purposes. Unsure if this reagent suits your experiment?

Need Industrial/Bulk Grade? [Request Custom Synthesis Quote](#)

BenchChem

Our mission is to be the trusted global source of essential and advanced chemicals, empowering scientists and researchers to drive progress in science and industry.

Contact

Address: 3281 E Guasti Rd

Ontario, CA 91761, United States

Phone: (601) 213-4426

Email: info@benchchem.com

Contact our Ph.D. Support Team for a compatibility check