

# Troubleshooting M2698 inconsistent Western blot results

**Author:** BenchChem Technical Support Team. **Date:** April 2026

## Compound of Interest

Compound Name: M2698  
CAS No.: 1379545-95-5  
Cat. No.: B608790

[Get Quote](#)

## Technical Support Center: M2698 Western Blot Analysis

This technical support center provides troubleshooting guidance and frequently asked questions (FAQs) for researchers using **M2698**, a dual p70S6K and Akt inhibitor, in Western blotting experiments.

### Frequently Asked Questions (FAQs)

Q1: What is **M2698** and what is its primary mechanism of action?

A1: **M2698** is a potent, orally bioavailable, and ATP-competitive dual inhibitor of p70 S6 Kinase (p70S6K) and Akt (specifically Akt1 and Akt3).[1][2][3] It targets the PI3K/Akt/mTOR (PAM) signaling pathway, which is a critical regulator of cell growth, proliferation, and metabolism.[1][2] Dysregulation of this pathway is common in many cancers.[1][2] **M2698**'s dual-action is designed to inhibit tumor growth by blocking p70S6K activity while simultaneously preventing the compensatory activation of Akt, a common resistance mechanism seen with other mTOR inhibitors.[1][4]

Q2: What are the key downstream targets to monitor by Western blot after **M2698** treatment?

A2: The primary downstream markers to assess **M2698** activity are the phosphorylation levels of substrates for p70S6K and Akt. Key targets include:

- Phospho-S6 Ribosomal Protein (p-S6): A substrate of p70S6K. A decrease in p-S6 (specifically at Ser240/244) is a direct indicator of p70S6K inhibition.[1][4]
- Phospho-GSK3 $\beta$  (p-GSK3 $\beta$ ): A substrate of Akt. A decrease in p-GSK3 $\beta$  (at Ser9) indicates Akt inhibition.[1][4]
- Phospho-Akt (p-Akt): While **M2698** inhibits Akt activity, some studies have observed a compensatory feedback loop that can lead to increased Akt phosphorylation (e.g., at Thr308) even as downstream signaling is blocked.[1][3] It is crucial to also measure total levels of these proteins (t-S6, t-GSK3 $\beta$ , t-Akt) to confirm that changes in phosphorylation are not due to changes in total protein expression.[1][4]

Q3: What concentrations of **M2698** are typically effective in cell culture experiments?

A3: The effective concentration of **M2698** can vary depending on the cell line and the duration of treatment. In vitro studies have shown **M2698** to be highly potent, with IC<sub>50</sub> values of 1 nM for p70S6K, Akt1, and Akt3.[2][3][5] Inhibition of downstream targets like pS6 and pGSK3 $\beta$  has been observed in the low nanomolar range (IC<sub>50</sub> = 11-17 nM).[1][4] For Western blot analysis, concentrations ranging from 0.3  $\mu$ M to 1  $\mu$ M for 24 hours have been effectively used to demonstrate inhibition of the PAM pathway in cell lines like HCC1419 and MDA-MB-453.[1][4]

## M2698 Potency and Efficacy Data

Target/Process	IC50 Value	Cell Line/System	Reference
p70S6K	1 nM	In vitro kinase assay	[1][2][5]
Akt1	1 nM	In vitro kinase assay	[1][2][5]
Akt3	1 nM	In vitro kinase assay	[1][2][5]
pS6 (indirect)	15 nM	In vivo	[1][2]
pGSK3 $\beta$ (indirect)	17 nM	MDA-MB-468 cells	[1][2]
Cell Proliferation	0.02-8.5 $\mu$ M	Breast cancer cell lines	[2][3]

## Western Blot Troubleshooting Guide

This guide addresses common issues encountered when performing Western blots to assess the effects of **M2698**.

### Issue 1: Weak or No Signal for Phosphorylated Proteins (e.g., p-S6, p-GSK3 $\beta$ )

- Possible Cause: Ineffective **M2698** treatment.
  - Solution: Ensure **M2698** was properly dissolved and added to the cell culture media at the desired final concentration. Verify the treatment duration and consider a time-course experiment to determine the optimal time point for observing maximal inhibition.
- Possible Cause: Low abundance of the target protein.
  - Solution: Increase the amount of protein loaded onto the gel.[6] Consider using a positive control cell line known to have high basal levels of the target protein.
- Possible Cause: Suboptimal antibody concentration.
  - Solution: Optimize the dilution of the primary and secondary antibodies.[6][7] Titrate the antibodies to find the concentration that provides the best signal-to-noise ratio.

- Possible Cause: Issues with protein transfer.
  - Solution: Confirm successful protein transfer from the gel to the membrane by staining the membrane with Ponceau S before blocking.[6] Ensure good contact between the gel and membrane and that no air bubbles are present.[7]

## Issue 2: High Background on the Western Blot

- Possible Cause: Insufficient blocking.
  - Solution: Increase the blocking time (e.g., 1-2 hours at room temperature or overnight at 4°C).[8] Use a fresh blocking buffer; 5% non-fat dry milk or bovine serum albumin (BSA) in TBST are common choices.[8]
- Possible Cause: Antibody concentration is too high.
  - Solution: Reduce the concentration of the primary and/or secondary antibodies.[8][9]
- Possible Cause: Inadequate washing.
  - Solution: Increase the number and duration of washes after primary and secondary antibody incubations.[6] Ensure the wash buffer contains a sufficient concentration of a gentle detergent like Tween-20 (e.g., 0.05-0.1%).[8]

## Issue 3: Non-Specific Bands are Observed

- Possible Cause: Primary antibody is not specific enough.
  - Solution: Use a highly specific monoclonal antibody if available.[9] Check the antibody datasheet to ensure it has been validated for Western blotting in the species you are using.
- Possible Cause: Protein overloading.
  - Solution: Reduce the total amount of protein loaded in each lane to minimize non-specific antibody binding.[6][9]
- Possible Cause: Sample degradation.

- Solution: Prepare fresh cell lysates and add protease and phosphatase inhibitors to the lysis buffer to prevent protein degradation.[10]

## Issue 4: Inconsistent Results Between Experiments

- Possible Cause: Variability in cell culture conditions.
  - Solution: Maintain consistent cell passage numbers, confluency at the time of treatment, and serum concentrations in the media.
- Possible Cause: Inconsistent sample preparation.
  - Solution: Ensure complete and consistent cell lysis and accurate protein concentration determination for equal loading.[6]
- Possible Cause: Procedural variations in the Western blot protocol.
  - Solution: Standardize all incubation times, temperatures, and washing steps.[7] Use fresh buffers for each experiment.

## Experimental Protocols

### Protocol 1: Cell Lysis and Protein Quantification

- After treating cells with **M2698** or vehicle control (e.g., 0.1% DMSO) for the desired time, wash the cells once with ice-cold PBS.[1][4]
- Aspirate the PBS and add ice-cold RIPA buffer supplemented with protease and phosphatase inhibitors.
- Scrape the cells and transfer the lysate to a pre-chilled microcentrifuge tube.
- Incubate on ice for 30 minutes, vortexing briefly every 10 minutes.
- Centrifuge the lysate at 14,000 x g for 15 minutes at 4°C.
- Transfer the supernatant (containing the protein) to a new tube.
- Determine the protein concentration using a BCA Protein Assay Kit.[1][4]

- Add 4x Laemmli sample buffer to the lysate and boil at 95-100°C for 5 minutes.

## Protocol 2: Western Blotting

- Load 30-50 µg of protein per lane onto an SDS-PAGE gel.[\[1\]](#)[\[4\]](#)
- Run the gel until the dye front reaches the bottom.
- Transfer the proteins to a PVDF or nitrocellulose membrane.
- Block the membrane with 5% non-fat dry milk or BSA in TBST for at least 1 hour at room temperature.[\[11\]](#)
- Incubate the membrane with the primary antibody (e.g., anti-p-S6, anti-p-GSK3β, anti-t-S6, anti-t-Akt from a reputable supplier like Cell Signaling Technologies) diluted in blocking buffer, typically overnight at 4°C with gentle agitation.[\[1\]](#)[\[4\]](#)
- Wash the membrane three times for 10 minutes each with TBST.
- Incubate the membrane with an appropriate HRP-conjugated secondary antibody (e.g., goat anti-rabbit IgG-HRP) diluted in blocking buffer for 1 hour at room temperature.[\[1\]](#)
- Wash the membrane three times for 10 minutes each with TBST.
- Add ECL substrate and visualize the bands using a chemiluminescence imaging system.
- If necessary, strip the membrane and re-probe for other proteins, such as a loading control (e.g., β-actin or GAPDH).

## Visualizations

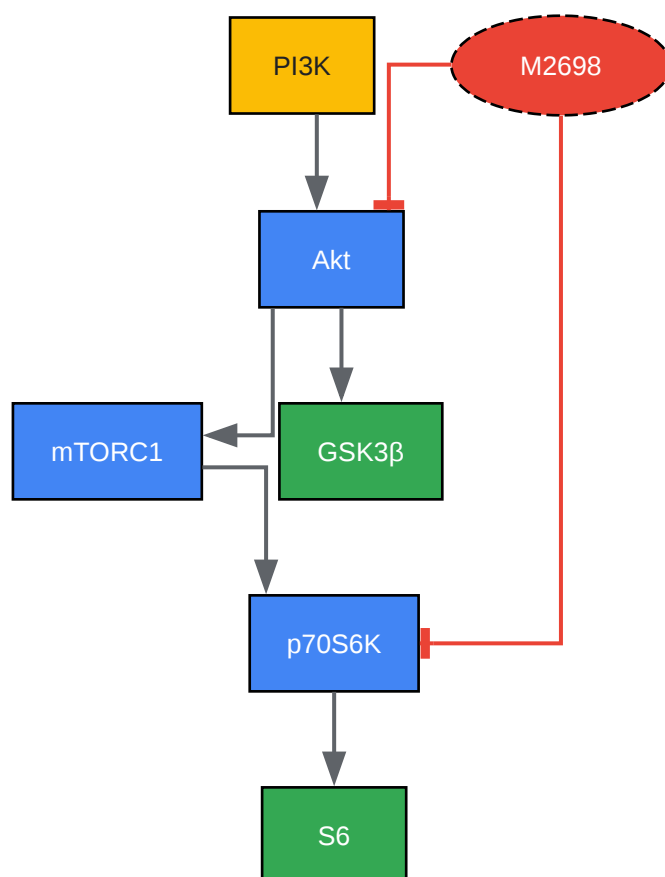

[Click to download full resolution via product page](#)

Caption: **M2698** inhibits the PI3K/Akt/mTOR pathway.

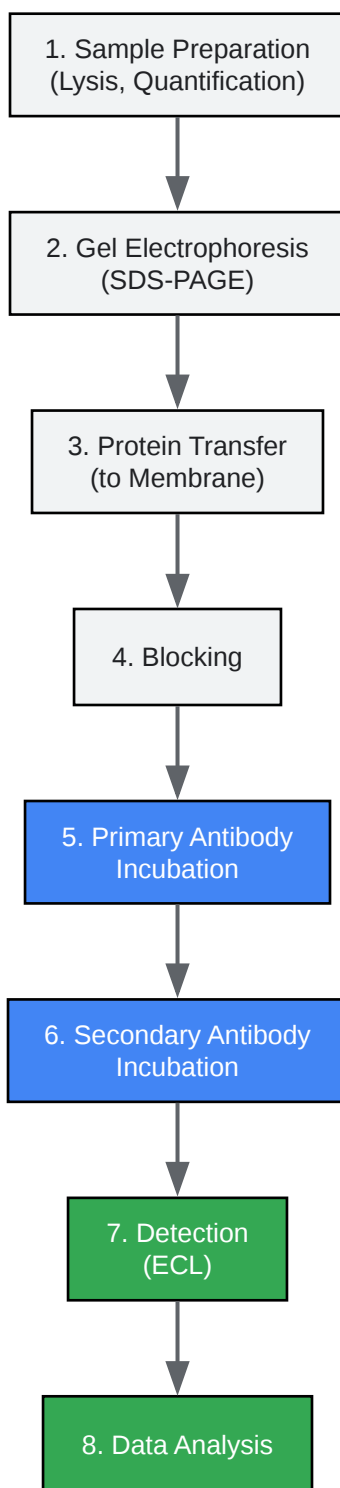

[Click to download full resolution via product page](#)

Caption: Standard workflow for Western blot analysis.

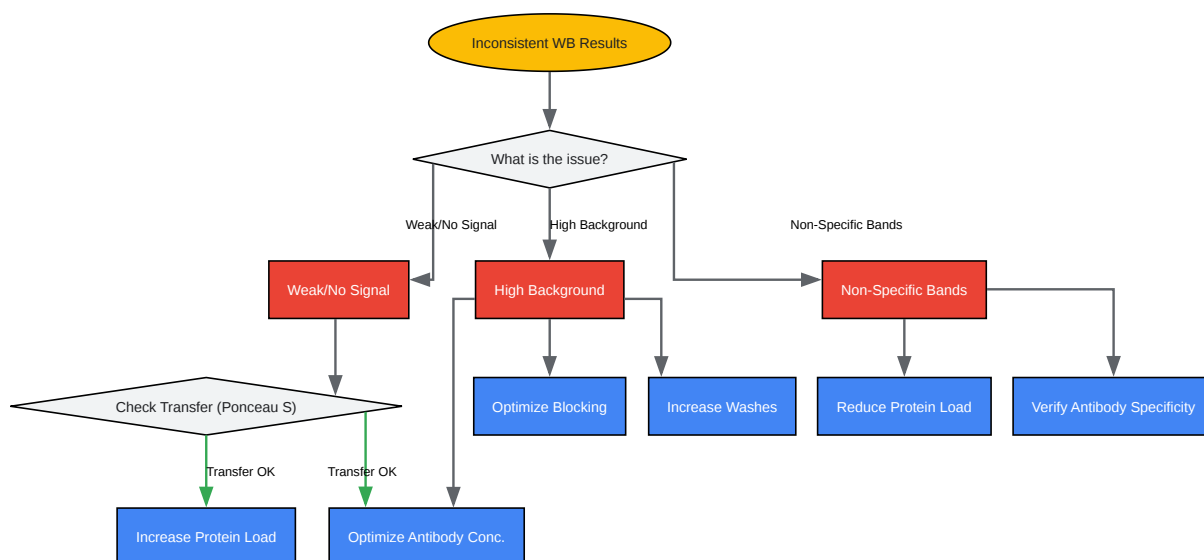

[Click to download full resolution via product page](#)

Caption: Decision tree for troubleshooting Western blots.

**Need Custom Synthesis?**

BenchChem offers custom synthesis for rare earth carbides and specific isotopic labeling.

Email: [info@benchchem.com](mailto:info@benchchem.com) or [Request Quote Online](#).

**References**

- 1. M2698 is a potent dual-inhibitor of p70S6K and Akt that affects tumor growth in mouse models of cancer and crosses the blood-brain barrier - PMC [pmc.ncbi.nlm.nih.gov]
- 2. medchemexpress.com [medchemexpress.com]
- 3. medchemexpress.com [medchemexpress.com]

- [4. e-century.us \[e-century.us\]](#)
- [5. M2698 is a potent dual-inhibitor of p70S6K and Akt that affects tumor growth in mouse models of cancer and crosses the blood-brain barrier - PubMed \[pubmed.ncbi.nlm.nih.gov\]](#)
- [6. Western Blot Troubleshooting Guide - TotalLab \[totallab.com\]](#)
- [7. Western Blot Troubleshooting: 10 Common Problems and Solutions \[synapse.patsnap.com\]](#)
- [8. bosterbio.com \[bosterbio.com\]](#)
- [9. What went wrong? A Western Blot Troubleshooting Guide \[precisionbiosystems.com\]](#)
- [10. southernbiotech.com \[southernbiotech.com\]](#)
- [11. Western blot protocol | Abcam \[abcam.com\]](#)
- [To cite this document: BenchChem. \[Troubleshooting M2698 inconsistent Western blot results\]. BenchChem, \[2026\]. \[Online PDF\]. Available at: \[https://www.benchchem.com/product/b608790/docs#troubleshooting-m2698-inconsistent-western-blot-results\]](#)

---

#### Disclaimer & Data Validity:

The information provided in this document is for Research Use Only (RUO) and is strictly not intended for diagnostic or therapeutic procedures. While BenchChem strives to provide accurate protocols, we make no warranties, express or implied, regarding the fitness of this product for every specific experimental setup.

**Technical Support:** The protocols provided are for reference purposes. Unsure if this reagent suits your experiment?

**Need Industrial/Bulk Grade?** [Request Custom Synthesis Quote](#)

## BenchChem

Our mission is to be the trusted global source of essential and advanced chemicals, empowering scientists and researchers to drive progress in science and industry.

#### Contact

Address: 3281 E Guasti Rd  
Ontario, CA 91761, United States  
Phone: (601) 213-4426  
Email: [info@benchchem.com](mailto:info@benchchem.com)

Contact our Ph.D. Support Team for a compatibility check