

Structural Analogs of KB-R7785: A Technical Guide for Drug Development Professionals

Author: BenchChem Technical Support Team. **Date:** April 2026

Compound of Interest

Compound Name:	KB-R7785
CAS No.:	168158-16-5
Cat. No.:	B608312

[Get Quote](#)

An In-depth Examination of N-Isobutyl-N-(4-methoxyphenylsulfonyl)glycyl Hydroxamic Acid and its Derivatives as Matrix Metalloproteinase Inhibitors

Abstract

KB-R7785, chemically known as N-isobutyl-N-(4-methoxyphenylsulfonyl)glycyl hydroxamic acid, is a potent, broad-spectrum inhibitor of matrix metalloproteinases (MMPs). This technical guide provides a comprehensive overview of the structural analogs of **KB-R7785**, focusing on their synthesis, structure-activity relationships (SAR), and pharmacological evaluation. By summarizing key quantitative data and detailing experimental methodologies, this document serves as a critical resource for researchers, scientists, and drug development professionals engaged in the discovery and design of novel MMP inhibitors.

Introduction: The Significance of KB-R7785 and its Analogs

Matrix metalloproteinases (MMPs) are a family of zinc-dependent endopeptidases crucial for the remodeling of the extracellular matrix (ECM). Their dysregulation is implicated in a

multitude of pathological conditions, including arthritis, cancer metastasis, and cardiovascular diseases. **KB-R7785** has emerged as a significant lead compound in the development of MMP inhibitors due to its potent and broad-spectrum activity.

The core structure of **KB-R7785**, a sulfonylated amino acid hydroxamate, presents multiple opportunities for chemical modification to enhance potency, selectivity, and pharmacokinetic properties. Understanding the structure-activity relationships of its analogs is paramount for the rational design of next-generation MMP inhibitors with improved therapeutic profiles. This guide will delve into the key structural motifs of **KB-R7785** and explore how their modification influences inhibitory activity.

Core Structure and Mechanism of Action

The inhibitory activity of **KB-R7785** and its analogs is primarily attributed to the hydroxamic acid moiety (-CONHOH), which acts as a potent zinc-chelating group, binding to the catalytic zinc ion in the active site of MMPs. The N-sulfonylated amino acid backbone provides a scaffold that can be tailored to interact with the various subsites (S1', S2', etc.) of the MMP active site, thereby influencing potency and selectivity.

The general structure of these analogs can be represented as $R^1-SO_2-N(R^2)-CH_2-CONHOH$, where:

- R^1 is the aryl group (4-methoxyphenyl in **KB-R7785**).
- R^2 is the alkyl group (isobutyl in **KB-R7785**).

The following diagram illustrates the proposed binding mode of sulfonylated amino acid hydroxamates to the MMP active site.

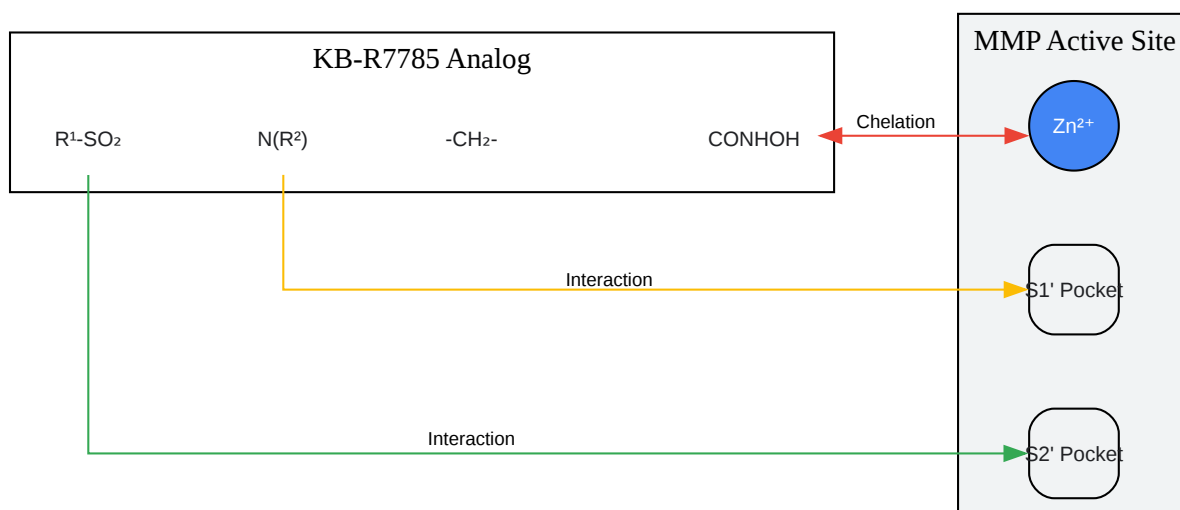

[Click to download full resolution via product page](#)

Figure 1: Proposed binding mode of **KB-R7785** analogs in the MMP active site.

Structure-Activity Relationship (SAR) of KB-R7785 Analogs

While a systematic SAR study on a comprehensive library of direct **KB-R7785** analogs is not extensively documented in publicly available literature, general principles can be derived from studies on related N-sulfonylated amino acid hydroxamates.^{[1][2]}

Modifications of the N-Alkyl Group (R^2)

The N-alkyl substituent (the isobutyl group in **KB-R7785**) primarily interacts with the $S1'$ pocket of the MMP active site. The size and nature of this group are critical for determining potency and selectivity.

Modifications of the Aryl Sulfonyl Group (R^1)

The aryl sulfonyl moiety (the 4-methoxyphenylsulfonyl group in **KB-R7785**) interacts with the $S2'$ and other subsites. Modifications to the substitution pattern and electronic properties of the aromatic ring can significantly impact inhibitory activity and selectivity across the MMP family.

Modifications of the Amino Acid Scaffold

While **KB-R7785** is a glycyl derivative, substituting the glycine with other amino acids introduces a side chain that can further probe the MMP active site, potentially leading to enhanced affinity and selectivity.

Quantitative Data on KB-R7785 and Related Analogs

The following table summarizes the inhibitory activity of **KB-R7785** (also referred to as NNGH) against various MMPs as reported in the literature. A comprehensive table of direct structural analogs is not available due to the limited publicly accessible data.

Compound	Target MMP	IC ₅₀ / K _i	Reference
KB-R7785 (NNGH)	MMP-1	0.17 μM (K _i)	[3]
MMP-3	0.13 μM (K _i)	[3]	
MMP-7	13 μM (K _i)	[3]	
MMP-8	9 nM (K _i)	[3]	
MMP-9	2.6 nM (K _i)	[3]	
MMP-10	0.1 μM (K _i)	[3]	
MMP-12	4.3 nM (K _i)	[3]	
MMP-13	3.1 nM (K _i)	[3]	
MMP-20	17 nM (K _i)	[3]	

Experimental Protocols

General Synthesis of N-Sulfonylated Amino Acid Hydroxamates

The synthesis of **KB-R7785** and its analogs generally follows a multi-step procedure. The following workflow provides a representative synthetic route.

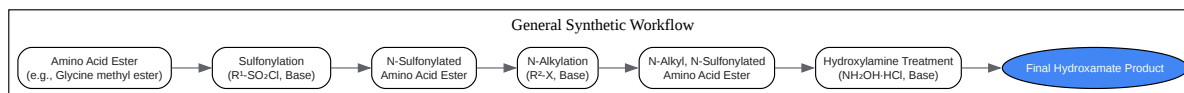

[Click to download full resolution via product page](#)

Figure 2: General synthetic workflow for N-sulfonylated amino acid hydroxamates.

A typical synthesis involves the following key steps:

- **Sulfonylation:** An amino acid ester hydrochloride is reacted with an appropriate arylsulfonyl chloride in the presence of a base (e.g., triethylamine) in a suitable solvent (e.g., dichloromethane) to yield the N-sulfonylated amino acid ester.
- **N-Alkylation:** The N-sulfonylated amino acid ester is then N-alkylated using an alkyl halide (e.g., isobutyl bromide) and a base (e.g., potassium carbonate) in a polar aprotic solvent (e.g., DMF).
- **Hydroxamate Formation:** The resulting ester is converted to the final hydroxamic acid by treatment with hydroxylamine hydrochloride and a base (e.g., sodium methoxide) in a solvent such as methanol.

MMP Inhibition Assay Protocol

The inhibitory activity of the synthesized compounds is typically evaluated using a fluorogenic substrate-based assay.

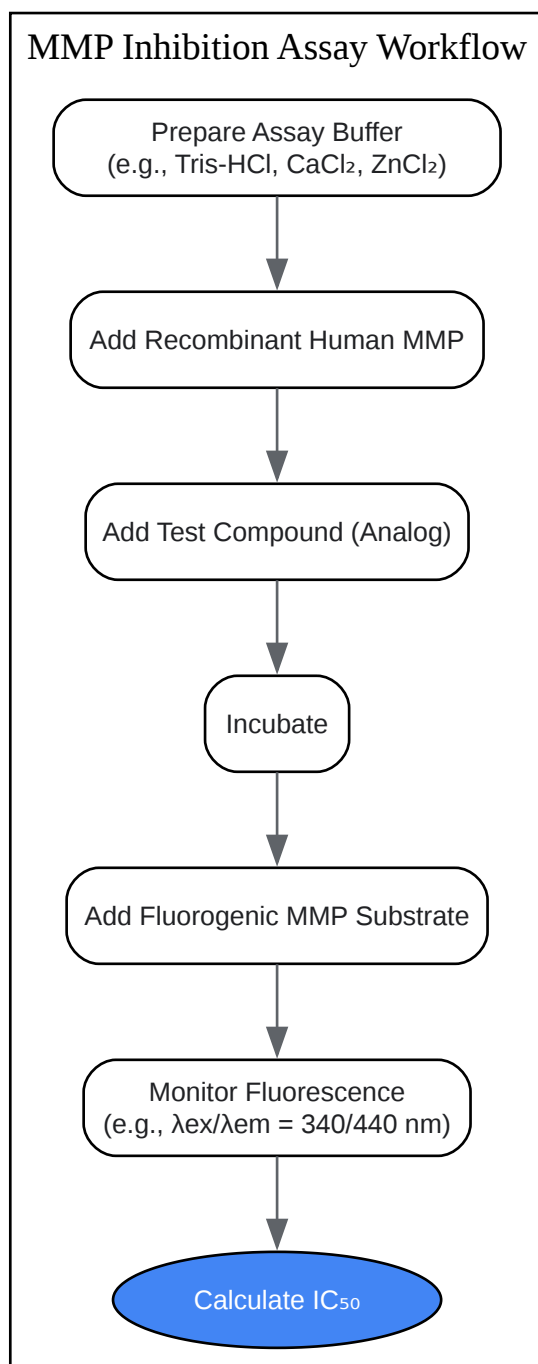

[Click to download full resolution via product page](#)

Figure 3: Workflow for a typical MMP inhibition assay.

The general procedure is as follows:

- Recombinant human MMP is pre-incubated with varying concentrations of the test compound in an appropriate assay buffer.
- A fluorogenic MMP substrate is added to initiate the enzymatic reaction.
- The increase in fluorescence, resulting from the cleavage of the substrate by the MMP, is monitored over time using a fluorescence plate reader.
- The initial reaction rates are determined, and the concentration of the inhibitor that causes 50% inhibition (IC_{50}) is calculated by fitting the data to a dose-response curve.

Conclusion and Future Directions

KB-R7785 remains a valuable scaffold for the design of novel MMP inhibitors. While the available data provides a foundational understanding of the SAR for N-sulfonylated amino acid hydroxamates, a more systematic and comprehensive exploration of the chemical space around the **KB-R7785** core is warranted. Future research should focus on the synthesis and evaluation of a diverse library of analogs with systematic modifications to the N-alkyl, aryl sulfonyl, and amino acid components. Such studies will be instrumental in developing highly potent and selective MMP inhibitors with improved therapeutic potential for a range of diseases. Furthermore, detailed pharmacokinetic and in vivo efficacy studies of promising analogs will be crucial for their translation into clinical candidates.

Need Custom Synthesis?

BenchChem offers custom synthesis for rare earth carbides and specific isotopic labeling.

Email: info@benchchem.com or [Request Quote Online](#).

References

1. pubs.acs.org [pubs.acs.org]
2. Carbonic anhydrase and matrix metalloproteinase inhibitors: sulfonylated amino acid hydroxamates with MMP inhibitory properties act as efficient inhibitors of CA isozymes I, II, and IV, and N-hydroxysulfonamides inhibit both these zinc enzymes - PubMed [pubmed.ncbi.nlm.nih.gov]
3. hetpdbnavi.nagahama-i-bio.ac.jp [hetpdbnavi.nagahama-i-bio.ac.jp]

- To cite this document: BenchChem. [Structural Analogs of KB-R7785: A Technical Guide for Drug Development Professionals]. BenchChem, [2026]. [Online PDF]. Available at: [\[https://www.benchchem.com/product/b608312/docs#structural-analogs-of-kb-r7785-a-technical-guide-for-drug-development-professionals\]](https://www.benchchem.com/product/b608312/docs#structural-analogs-of-kb-r7785-a-technical-guide-for-drug-development-professionals)

Disclaimer & Data Validity:

The information provided in this document is for Research Use Only (RUO) and is strictly not intended for diagnostic or therapeutic procedures. While BenchChem strives to provide accurate protocols, we make no warranties, express or implied, regarding the fitness of this product for every specific experimental setup.

Technical Support: The protocols provided are for reference purposes. Unsure if this reagent suits your experiment?

Need Industrial/Bulk Grade? [Request Custom Synthesis Quote](#)

BenchChem

Our mission is to be the trusted global source of essential and advanced chemicals, empowering scientists and researchers to drive progress in science and industry.

Contact

Address: 3281 E Guasti Rd
Ontario, CA 91761, United States
Phone: (601) 213-4426
Email: info@benchchem.com

[Contact our Ph.D. Support Team for a compatibility check](#)