

M2698: A Comparative Analysis Across Diverse Cancer Cell Lines

Author: BenchChem Technical Support Team. **Date:** April 2026

Compound of Interest

Compound Name: M2698
CAS No.: 1379545-95-5
Cat. No.: B608790

[Get Quote](#)

For Researchers, Scientists, and Drug Development Professionals

This guide provides a comprehensive comparative analysis of the p70S6K/Akt dual inhibitor, **M2698**, across various cancer cell lines. The information presented herein is supported by experimental data to aid in the evaluation of its therapeutic potential.

M2698 is an orally active, ATP-competitive inhibitor of p70S6K and Akt, key components of the PI3K/Akt/mTOR (PAM) signaling pathway, which is frequently dysregulated in cancer.[1][2][3] Its dual-inhibitor nature allows it to circumvent the compensatory feedback loop that often limits the efficacy of other PAM pathway inhibitors.[1][2] Furthermore, **M2698** has demonstrated the ability to cross the blood-brain barrier, suggesting its potential for treating central nervous system malignancies.[1][2][3]

Comparative Efficacy of M2698 in Cancer Cell Lines

The anti-proliferative activity of **M2698** has been evaluated across a broad panel of cancer cell lines. While a comprehensive dataset for all 81 tested cell lines is not publicly available in

tabular format, the following tables summarize the available quantitative data, primarily focusing on breast cancer models.

Biochemical and Cellular Potency of M2698

Target	IC50 (nM)	Cell Line/Assay Condition
p70S6K	1	Biochemical Assay
Akt1	1	Biochemical Assay
Akt3	1	Biochemical Assay
pGSK3 β (indirect)	17	MDA-MB-468 cells
pS6 (indirect)	15	In vivo

Table 1: Biochemical and cellular IC50 values of **M2698** against its primary targets and downstream effectors. Data sourced from[1][2][3][4][5].

Anti-proliferative Activity of M2698 in Breast Cancer Cell Lines

Cell Line	Subtype	IC50 (μ M)
BT-474	Luminal	0.02
T-47D	Luminal	0.03
ZR-75-1	Luminal	0.4
MCF7	Luminal	0.8
MDA-MB-468	Triple-Negative	0.3
MDA-MB-453	HER2-Expressing	1.1
JIMT-1	HER2-Positive	0.9
HCC1419	HER2 Amplification	1.0
SK-BR-3	HER2-Positive	8.5

Table 2: Proliferation inhibition (IC50) of **M2698** in a panel of breast cancer cell lines after 72 hours of treatment. Data from[1][5].

In addition to breast cancer, **M2698** has shown significant anti-tumor activity in a U251 glioblastoma xenograft model, where it reduced tumor burden and prolonged survival.[1][2] In a triple-negative breast cancer (TNBC) xenograft model using MDA-MB-468 cells, **M2698** led to dose-dependent tumor growth inhibition, with the highest doses resulting in tumor regression. [1][2]

Signaling Pathway and Experimental Workflow

To visually represent the mechanism of action and experimental procedures, the following diagrams have been generated using Graphviz.

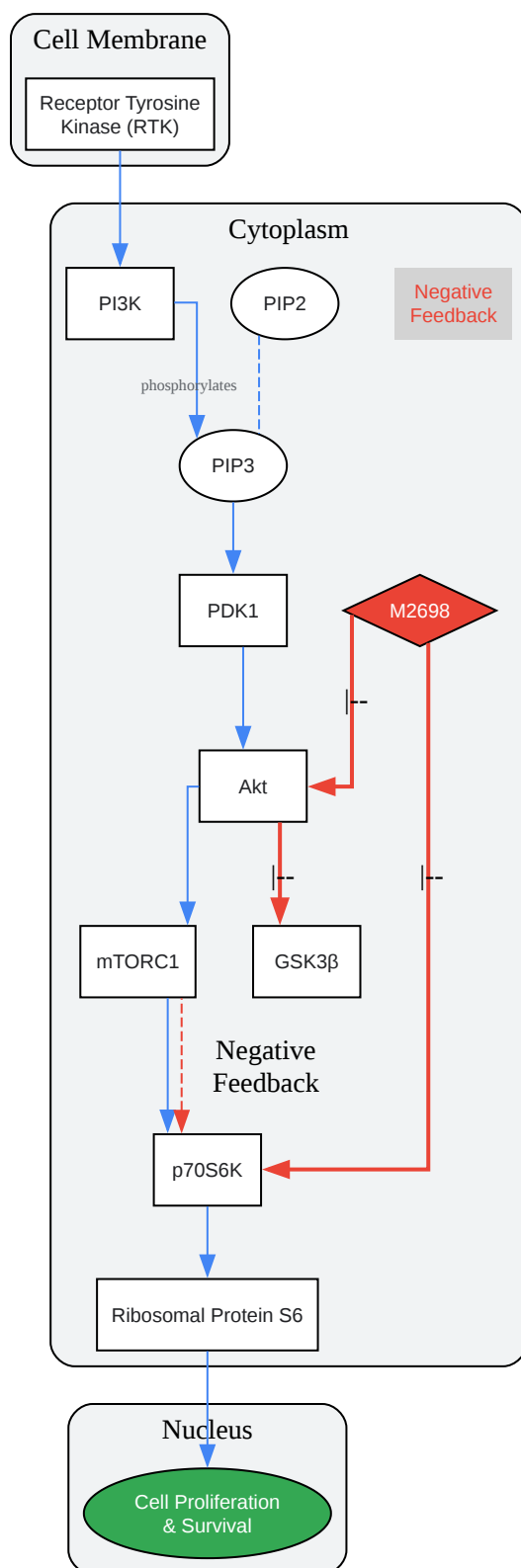

[Click to download full resolution via product page](#)

Caption: **M2698** inhibits the PI3K/Akt/mTOR pathway by targeting p70S6K and Akt.

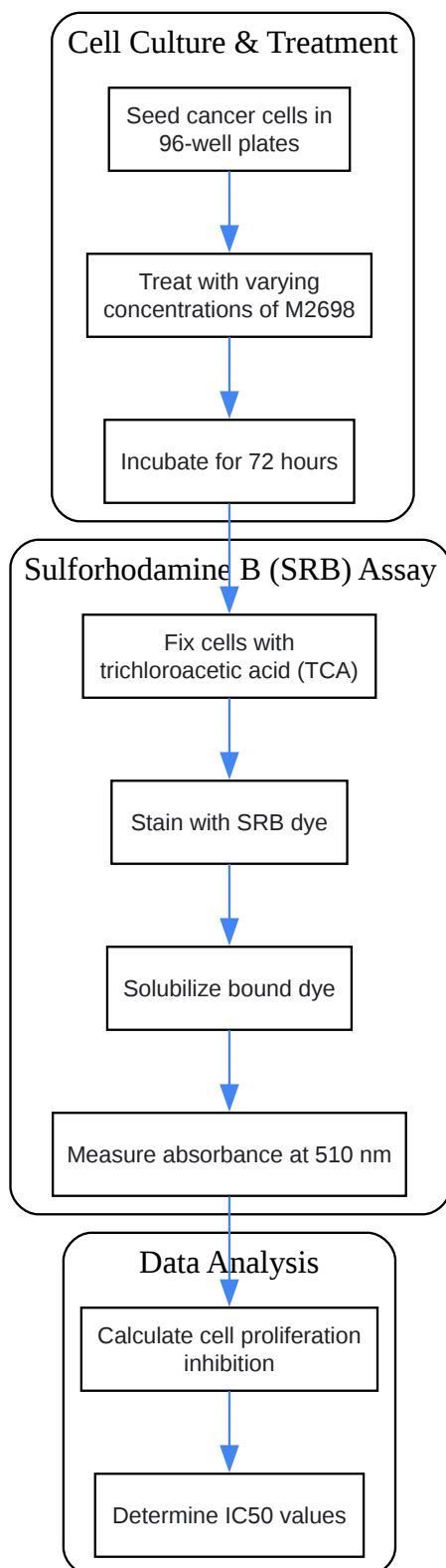

[Click to download full resolution via product page](#)

Need Custom Synthesis?

BenchChem offers custom synthesis for rare earth carbides and specific isotopic labeling.

Email: info@benchchem.com or [Request Quote Online](#).

References

- 1. M2698 is a potent dual-inhibitor of p70S6K and Akt that affects tumor growth in mouse models of cancer and crosses the blood-brain barrier - PMC [[pmc.ncbi.nlm.nih.gov](https://pubmed.ncbi.nlm.nih.gov)]
- 2. [e-century.us](https://www.e-century.us) [[e-century.us](https://www.e-century.us)]
- 3. M2698 is a potent dual-inhibitor of p70S6K and Akt that affects tumor growth in mouse models of cancer and crosses the blood-brain barrier - PubMed [pubmed.ncbi.nlm.nih.gov]
- 4. [medchemexpress.com](https://www.medchemexpress.com) [[medchemexpress.com](https://www.medchemexpress.com)]
- 5. [file.medchemexpress.com](https://www.file.medchemexpress.com) [[file.medchemexpress.com](https://www.file.medchemexpress.com)]
- To cite this document: BenchChem. [M2698: A Comparative Analysis Across Diverse Cancer Cell Lines]. BenchChem, [2026]. [Online PDF]. Available at: [<https://www.benchchem.com/product/b608790/docs#m2698-a-comparative-analysis-across-diverse-cancer-cell-lines>]

Disclaimer & Data Validity:

The information provided in this document is for Research Use Only (RUO) and is strictly not intended for diagnostic or therapeutic procedures. While BenchChem strives to provide accurate protocols, we make no warranties, express or implied, regarding the fitness of this product for every specific experimental setup.

Technical Support: The protocols provided are for reference purposes. Unsure if this reagent suits your experiment?

Need Industrial/Bulk Grade? [Request Custom Synthesis Quote](#)

BenchChem

Our mission is to be the trusted global source of essential and advanced chemicals, empowering scientists and researchers to drive progress in science and industry.

Contact

Address: 3281 E Guasti Rd

Ontario, CA 91761, United States

Phone: (601) 213-4426

Email: info@benchchem.com

[Contact our Ph.D. Support Team for a compatibility check](#)