

Application of Hydroxy-PEG2-acid in PROTAC Development: Detailed Application Notes and Protocols

Author: BenchChem Technical Support Team. **Date:** April 2026

Compound of Interest

Compound Name: *Hydroxy-PEG2-acid*

Cat. No.: *B608002*

[Get Quote](#)

For Researchers, Scientists, and Drug Development Professionals

Introduction

Proteolysis-targeting chimeras (PROTACs) have emerged as a revolutionary therapeutic modality, offering the ability to selectively eliminate target proteins by hijacking the cell's natural ubiquitin-proteasome system. A PROTAC molecule is a heterobifunctional entity composed of three key components: a ligand that binds to the protein of interest (POI), a ligand that recruits an E3 ubiquitin ligase, and a chemical linker that connects the two. The linker is a critical determinant of a PROTAC's efficacy, influencing its physicochemical properties, cell permeability, and the stability of the ternary complex formed between the POI and the E3 ligase.

Among the various linker types, polyethylene glycol (PEG)-based linkers are frequently employed due to their hydrophilicity, biocompatibility, and tunable length. **Hydroxy-PEG2-acid**, a short-chain PEG linker with a terminal carboxylic acid and a hydroxyl group, is a versatile building block in PROTAC synthesis. The carboxylic acid allows for straightforward amide bond formation with an amine-containing ligand (either for the POI or the E3 ligase), while the

hydroxyl group can be further functionalized if needed. This application note provides a detailed overview of the use of **Hydroxy-PEG2-acid** in PROTAC development, including synthesis protocols, quantitative data on PROTAC efficacy, and methods for biological evaluation.

The Role of Hydroxy-PEG2-acid in PROTAC Design

The incorporation of a **Hydroxy-PEG2-acid** linker in a PROTAC offers several advantages:

- **Enhanced Solubility:** The hydrophilic nature of the PEG chain can improve the aqueous solubility of the PROTAC molecule, which is often a challenge for these relatively large molecules.[1]
- **Improved Cell Permeability:** By balancing the overall lipophilicity, PEG linkers can enhance the cell permeability of PROTACs, a crucial factor for their biological activity.
- **Optimal Vector and Length:** The short and defined length of the PEG2 unit provides a specific spatial orientation between the two ligands, which is critical for the formation of a stable and productive ternary complex.
- **Synthetic Tractability:** The terminal carboxylic acid provides a convenient handle for standard amide coupling reactions, simplifying the synthesis of PROTAC libraries for optimization.

Quantitative Data on PROTACs Utilizing PEG2 Linkers

The efficacy of a PROTAC is typically assessed by its ability to induce the degradation of the target protein, quantified by the DC50 (the concentration of PROTAC that induces 50% degradation) and Dmax (the maximum percentage of degradation) values. Below is a summary of quantitative data for a PROTAC utilizing a PEG2 linker.

PROTAC Name	Target Protein	E3 Ligase Ligand	Linker	DC50 (nM)	Dmax (%)	Cell Line	Reference
sEH PROTAC 21b	sEH	Pomalidomide	PEG2-triazole	~100-300	~75	HeLa	[2]
sEH PROTAC 22b	sEH	Pomalidomide	PEG2-triazole	~100-300	~80	HeLa	[2]

Experimental Protocols

Protocol 1: Synthesis of a PROTAC using Hydroxy-PEG2-acid

This protocol describes a general procedure for the synthesis of a PROTAC where **Hydroxy-PEG2-acid** is coupled to an amine-containing E3 ligase ligand, followed by coupling to the POI ligand.

Diagram of the Synthetic Workflow:

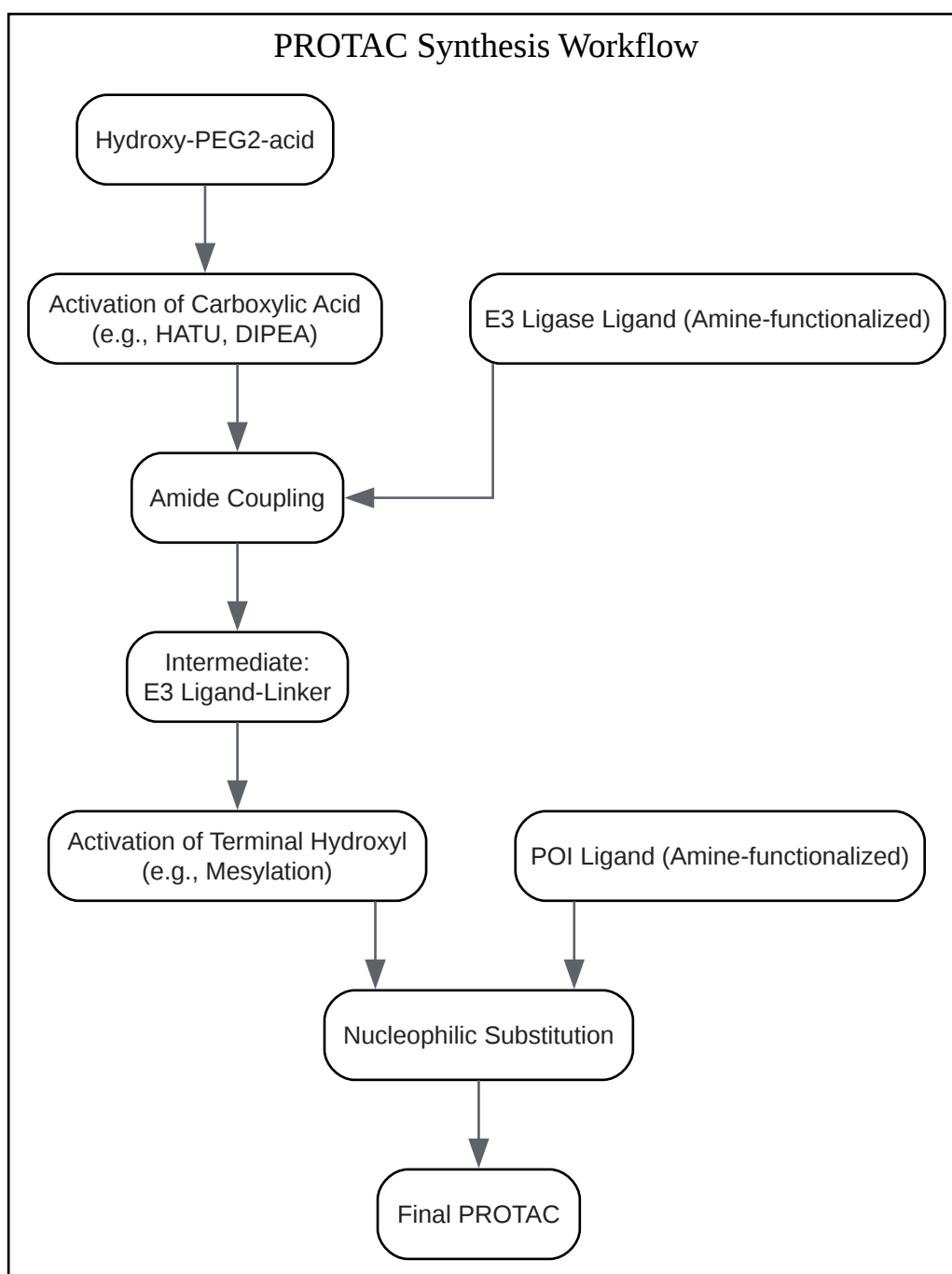

[Click to download full resolution via product page](#)

Caption: General workflow for PROTAC synthesis using **Hydroxy-PEG2-acid**.

Materials:

- **Hydroxy-PEG2-acid**

- Amine-functionalized E3 ligase ligand (e.g., pomalidomide derivative)
- Amine-functionalized POI ligand
- HATU (1-[Bis(dimethylamino)methylene]-1H-1,2,3-triazolo[4,5-b]pyridinium 3-oxid hexafluorophosphate)
- DIPEA (N,N-Diisopropylethylamine)
- Anhydrous DMF (N,N-Dimethylformamide)
- Anhydrous DCM (Dichloromethane)
- Trifluoroacetic acid (TFA) (if Boc protection is used)
- Saturated aqueous NaHCO₃ solution
- Brine
- Anhydrous Na₂SO₄
- Silica gel for column chromatography
- Solvents for column chromatography (e.g., ethyl acetate, hexanes, methanol)

Procedure:

Step 1: Coupling of **Hydroxy-PEG2-acid** to the E3 Ligase Ligand

- Dissolve the amine-functionalized E3 ligase ligand (1.0 eq) and **Hydroxy-PEG2-acid** (1.2 eq) in anhydrous DMF.
- Add HATU (1.5 eq) and DIPEA (3.0 eq) to the solution.
- Stir the reaction mixture at room temperature under a nitrogen atmosphere for 4-16 hours.
- Monitor the reaction progress by LC-MS.

- Once the reaction is complete, dilute the mixture with ethyl acetate and wash with saturated aqueous NaHCO₃, water, and brine.
- Dry the organic layer over anhydrous Na₂SO₄, filter, and concentrate under reduced pressure.
- Purify the crude product by flash column chromatography on silica gel to obtain the E3 ligase-linker intermediate.

Step 2: Coupling of the E3 Ligase-Linker Intermediate to the POI Ligand

This step assumes the hydroxyl group of the PEG linker is activated (e.g., by mesylation) for reaction with an amine on the POI ligand. Alternatively, the POI ligand could have a carboxylic acid for amide coupling to an amine-functionalized linker.

- Activate the terminal hydroxyl group of the E3 ligase-linker intermediate. (This step will vary based on the desired linkage).
- Dissolve the activated E3 ligase-linker intermediate (1.0 eq) and the amine-functionalized POI ligand (1.1 eq) in anhydrous DMF.
- Add a suitable base (e.g., DIPEA, 3.0 eq) if necessary.
- Stir the reaction at room temperature or with gentle heating under a nitrogen atmosphere until completion, as monitored by LC-MS.
- Work-up the reaction as described in Step 1.
- Purify the final PROTAC compound by flash column chromatography or preparative HPLC.

Protocol 2: Western Blot for PROTAC-Mediated Protein Degradation

This protocol details the steps to assess the degradation of a target protein in cells treated with a PROTAC.

Diagram of the Western Blot Workflow:

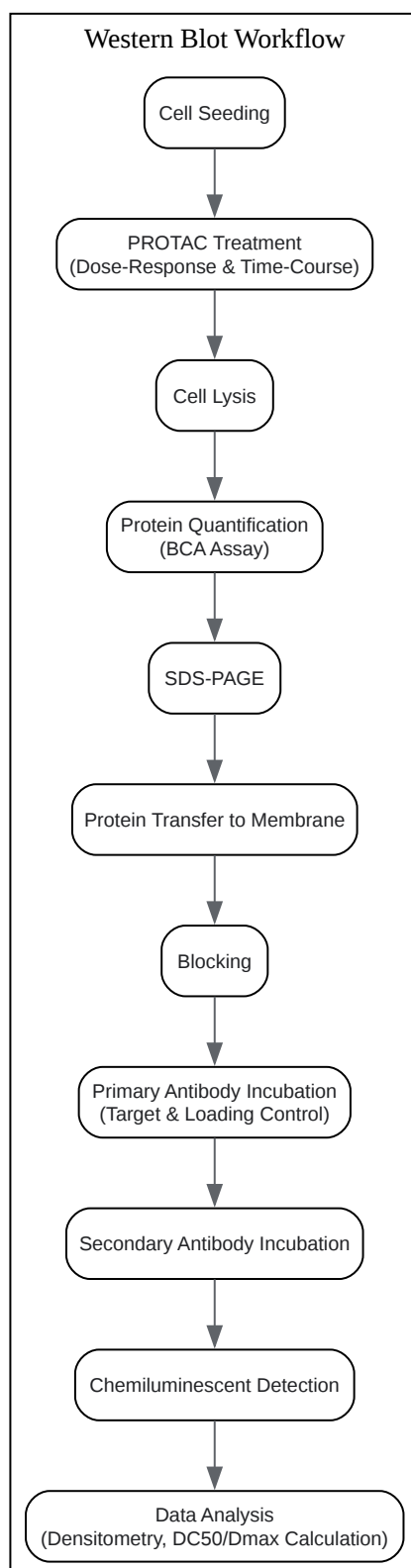

[Click to download full resolution via product page](#)

Caption: Workflow for assessing PROTAC-mediated protein degradation via Western Blot.

Materials:

- Cell line expressing the target protein
- Complete cell culture medium
- PROTAC stock solution (in DMSO)
- Vehicle control (DMSO)
- Ice-cold PBS (Phosphate-Buffered Saline)
- RIPA lysis buffer supplemented with protease and phosphatase inhibitors
- BCA protein assay kit
- Laemmli sample buffer
- SDS-PAGE gels and running buffer
- PVDF or nitrocellulose membrane
- Transfer buffer
- Blocking buffer (e.g., 5% non-fat milk or BSA in TBST)
- Primary antibody against the target protein
- Primary antibody against a loading control (e.g., GAPDH, β -actin)
- HRP-conjugated secondary antibody
- Chemiluminescent substrate
- Imaging system

Procedure:

- **Cell Seeding:** Seed cells in 6-well plates at a density that allows them to reach 70-80% confluency at the time of harvest. Allow cells to adhere overnight.
- **PROTAC Treatment:** Treat the cells with a serial dilution of the PROTAC to determine the dose-response. Include a vehicle-only control. For time-course experiments, treat cells with a fixed concentration of the PROTAC and harvest at different time points (e.g., 2, 4, 8, 16, 24 hours).
- **Cell Lysis:** After treatment, aspirate the medium and wash the cells with ice-cold PBS. Add lysis buffer to each well, scrape the cells, and collect the lysate.
- **Protein Quantification:** Determine the protein concentration of each lysate using a BCA assay.
- **Sample Preparation:** Normalize the protein concentration of all samples with lysis buffer. Add Laemmli sample buffer and boil the samples at 95°C for 5 minutes.
- **SDS-PAGE and Transfer:** Load equal amounts of protein onto an SDS-PAGE gel and separate the proteins by electrophoresis. Transfer the separated proteins to a PVDF or nitrocellulose membrane.
- **Immunoblotting:**
 - Block the membrane with blocking buffer for 1 hour at room temperature.
 - Incubate the membrane with the primary antibody against the target protein overnight at 4°C.
 - Wash the membrane with TBST.
 - Incubate with the HRP-conjugated secondary antibody for 1 hour at room temperature.
 - Wash the membrane with TBST.
 - Repeat the process for the loading control antibody.
- **Detection and Analysis:** Apply the chemiluminescent substrate and capture the signal using an imaging system. Quantify the band intensities using densitometry software. Normalize the

target protein levels to the loading control. Calculate DC50 and Dmax values from the dose-response data.

Protocol 3: NanoBRET™ Assay for Ternary Complex Formation

This protocol outlines a method to assess the formation of the ternary complex in live cells.[3]
[4]

Diagram of the NanoBRET™ Workflow:

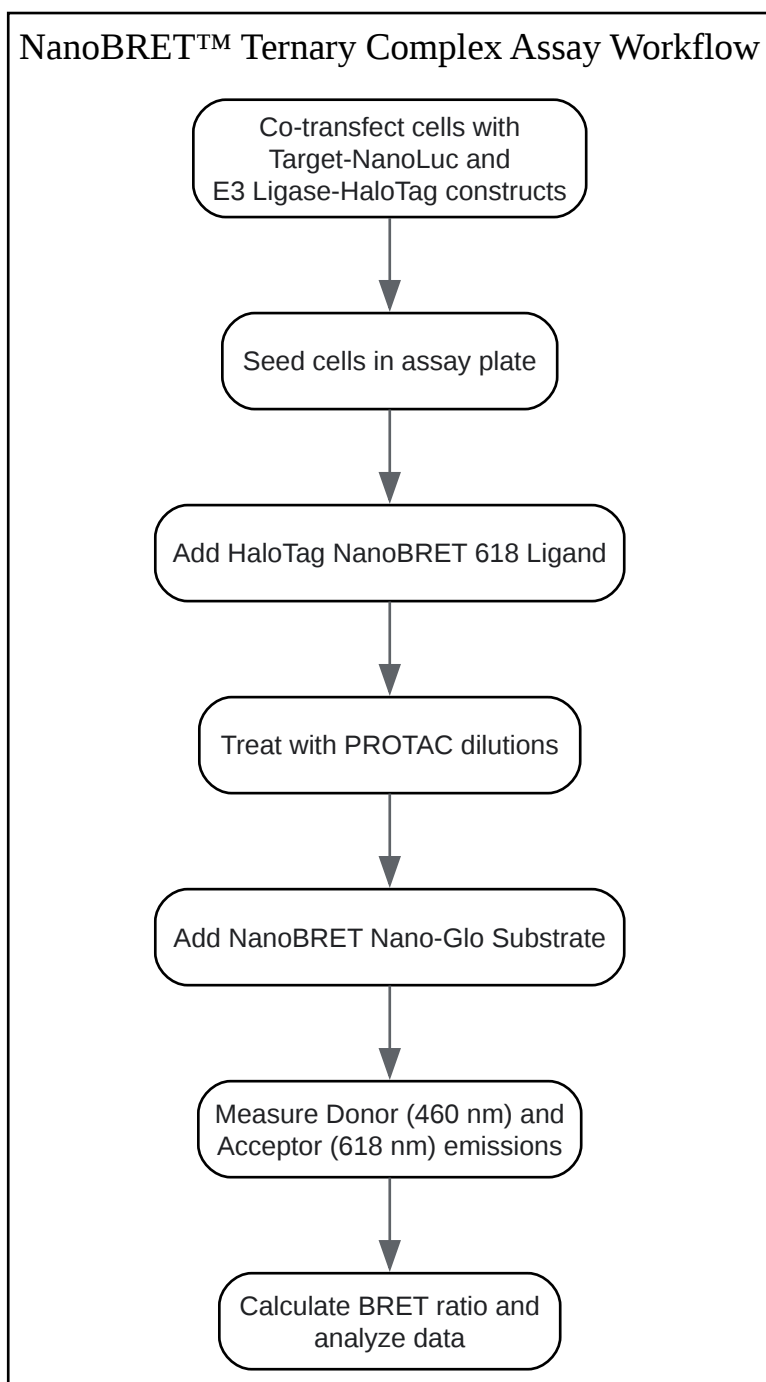

[Click to download full resolution via product page](#)

Caption: Workflow for the NanoBRET™ ternary complex formation assay.

Materials:

- HEK293T cells

- Expression vectors for:
 - Target protein fused to NanoLuc® luciferase (Donor)
 - E3 ligase (e.g., CRBN or VHL) fused to HaloTag® (Acceptor)
- Transfection reagent
- Opti-MEM™ I Reduced Serum Medium
- White, 96-well assay plates
- HaloTag® NanoBRET® 618 Ligand
- PROTAC stock solution
- NanoBRET® Nano-Glo® Substrate
- Luminometer capable of measuring donor and acceptor wavelengths

Procedure:

- Cell Transfection: Co-transfect HEK293T cells with the NanoLuc-tagged target protein and HaloTag-tagged E3 ligase expression vectors.
- Cell Seeding: The following day, seed the transfected cells into a white 96-well plate.
- HaloTag® Labeling: Add the HaloTag® NanoBRET® 618 Ligand to the cells and incubate to allow labeling of the HaloTag-E3 ligase fusion protein.
- PROTAC Treatment: Prepare a serial dilution of the PROTAC in Opti-MEM™ and add to the appropriate wells. Include a vehicle control. Incubate for a defined period (e.g., 2 hours) at 37°C.
- Luminescence Measurement: Add the NanoBRET® Nano-Glo® Substrate to all wells.
- Data Acquisition: Measure the donor emission at 460 nm and the acceptor emission at >610 nm using a luminometer.

- **Data Analysis:** Calculate the raw BRET ratio by dividing the acceptor signal by the donor signal. Plot the BRET ratio against the PROTAC concentration. The characteristic "hook effect" curve indicates ternary complex formation.

Signaling Pathways

Understanding the signaling pathways of the E3 ligase and the target protein is crucial for rational PROTAC design and for predicting potential biological consequences of protein degradation.

Cereblon (CRBN) E3 Ligase Signaling

Cereblon is the substrate receptor of the CRL4-CRBN E3 ubiquitin ligase complex. It plays a role in various cellular processes, and its activity can be modulated by immunomodulatory drugs (IMiDs) like thalidomide and its analogs, which are common E3 ligase ligands in PROTACs.

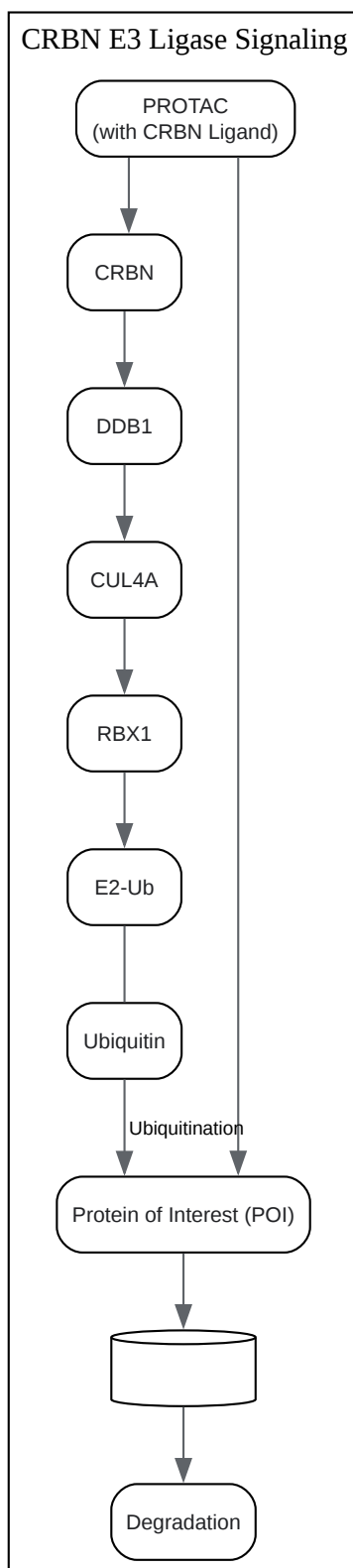

[Click to download full resolution via product page](#)

Caption: PROTAC-mediated protein degradation via the CRL4-CRBN E3 ligase complex.

BRD4 Signaling Pathway

BRD4 is a member of the bromodomain and extraterminal (BET) family of proteins that acts as an epigenetic reader, binding to acetylated histones and recruiting transcriptional machinery to drive the expression of key oncogenes like c-MYC. Degradation of BRD4 is a promising anti-cancer strategy.

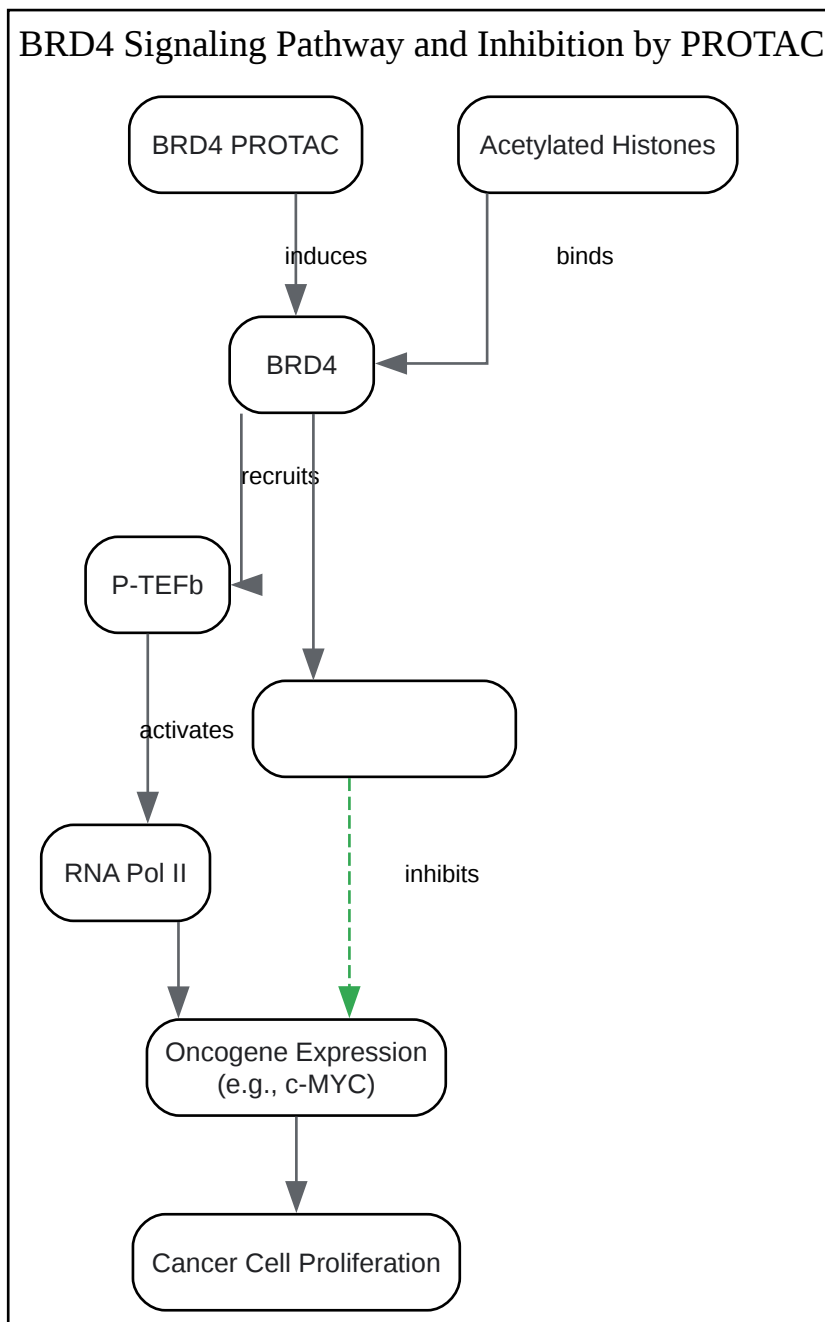

[Click to download full resolution via product page](#)

Caption: BRD4 signaling and its disruption by a BRD4-targeting PROTAC.

Conclusion

Hydroxy-PEG2-acid is a valuable and versatile linker for the development of PROTACs. Its properties can contribute to improved solubility and permeability, while its defined length and synthetic accessibility make it a useful tool for optimizing PROTAC efficacy. The protocols provided herein offer a framework for the synthesis and biological evaluation of PROTACs incorporating this linker. As the field of targeted protein degradation continues to expand, the rational design of linkers, including the strategic use of building blocks like **Hydroxy-PEG2-acid**, will remain a cornerstone of successful PROTAC development.

Need Custom Synthesis?

BenchChem offers custom synthesis for rare earth carbides and specific isotopic labeling.

Email: info@benchchem.com or [Request Quote Online](#).

References

- [1. Characteristic roadmap of linker governs the rational design of PROTACs - PMC \[pmc.ncbi.nlm.nih.gov\]](#)
- [2. biorxiv.org \[biorxiv.org\]](#)
- [3. benchchem.com \[benchchem.com\]](#)
- [4. benchchem.com \[benchchem.com\]](#)
- To cite this document: BenchChem. [Application of Hydroxy-PEG2-acid in PROTAC Development: Detailed Application Notes and Protocols]. BenchChem, [2026]. [Online PDF]. Available at: [<https://www.benchchem.com/product/b608002/docs#application-of-hydroxy-peg2-acid-in-protac-development-detailed-application-notes-and-protocols>]

Disclaimer & Data Validity:

The information provided in this document is for Research Use Only (RUO) and is strictly not intended for diagnostic or therapeutic procedures. While BenchChem strives to provide

accurate protocols, we make no warranties, express or implied, regarding the fitness of this product for every specific experimental setup.

Technical Support: The protocols provided are for reference purposes. Unsure if this reagent suits your experiment?

Need Industrial/Bulk Grade? [Request Custom Synthesis Quote](#)

BenchChem

Our mission is to be the trusted global source of essential and advanced chemicals, empowering scientists and researchers to drive progress in science and industry.

Contact

Address: 3281 E Guasti Rd

Ontario, CA 91761, United States

Phone: (601) 213-4426

Email: info@benchchem.com

[Contact our Ph.D. Support Team for a compatibility check](#)