

Application Notes and Protocols for Developing Kefiran-Based Scaffolds in Tissue Engineering

Author: BenchChem Technical Support Team. **Date:** April 2026

Compound of Interest

Compound Name:	Kefiran
CAS No.:	86753-15-3
Cat. No.:	B608327

[Get Quote](#)

For Researchers, Scientists, and Drug Development Professionals

These application notes provide a comprehensive guide to the development and characterization of **kefiran**-based scaffolds for tissue engineering applications. **Kefiran**, a microbial exopolysaccharide derived from kefir grains, has garnered significant interest due to its biocompatibility, biodegradability, and inherent antimicrobial and anti-inflammatory properties.[1][2] This document outlines detailed protocols for **kefiran** extraction, scaffold fabrication using various techniques, and methods for their physicochemical and biological characterization.

I. Overview of Kefiran for Tissue Engineering

Kefiran is a water-soluble glucogalactan that can be fabricated into various scaffold architectures, including porous matrices and nanofibrous meshes.[2][3] These scaffolds provide a supportive environment for cell attachment, proliferation, and differentiation, making them suitable for a range of tissue engineering applications, including skin, bone, and cartilage regeneration.[4][5][6] The inherent bioactivity of **kefiran** can also modulate the local inflammatory response and promote tissue repair.[4]

II. Quantitative Data Summary

The following tables summarize the key quantitative properties of **kefiran**-based scaffolds from various studies, providing a comparative overview for researchers.

Table 1: Physicochemical Properties of **Kefiran**-Based Scaffolds

Scaffold Type	Fabrication Method	Porosity (%)	Pore Size (μm)	Wall Thickness (μm)	Molecular Weight (kDa)	Melting Temperature ($^{\circ}\text{C}$)
Kefiran Cryogel	Cryogelation & Freeze-drying	93.2 ± 2.0	94 - 98	85.8 ± 16.3	~3000	~99
Methacrylated Kefiran Cryogel	Cryogelation & Freeze-drying	85.53 ± 0.15	33.67 ± 3.13	11.92 ± 0.44	793	-
PLA/Kefiran Composite	Electrospinning & Coating	-	-	-	-	-
PAN/Kefiran Nanofiber	Electrospinning	-	0.310 ± 0.044	-	-	-
4% Kefiran Scaffold	TIPS	-	-	-	-	106

Table 2: Biological Properties of **Kefiran**-Based Scaffolds

Scaffold Type	Cell Type	Assay	Key Findings
Kefiran Cryogels	L929 mouse fibroblasts	Cytotoxicity	Non-cytotoxic, enhanced cell proliferation.[6]
PAN/Kefiran Nanofibers	PC12 cells	Cell Attachment & Proliferation	Enhanced cell attachment and proliferation.[5]
PAN/Kefiran Nanofibers	MCF7 breast cancer cells	Cytotoxicity	Decreased viability of cancer cells.[5]
Kefiran-treated medium	ECV cells	Cell Viability (CCK8)	Significant faster cell proliferation.[3]

III. Experimental Protocols

This section provides detailed methodologies for key experiments in the development and evaluation of **kefiran**-based scaffolds.

Protocol 1: Extraction and Purification of Kefiran

This protocol is adapted from methodologies described in multiple studies.[3][6]

Materials:

- Kefir grains
- Ultrapure water
- Ethanol (96-100%)
- Centrifuge
- Freeze-dryer

Procedure:

- Wash kefir grains with ultrapure water.

- Suspend the grains in hot ultrapure water (80°C) at a 1:10 (w/v) ratio.
- Stir the suspension for 30 minutes.
- Centrifuge the mixture at 10,000 x g for 20 minutes at 4°C.[3]
- Collect the supernatant.
- Add two volumes of cold ethanol to the supernatant to precipitate the **kefir**.
- Store the mixture at -20°C overnight.
- Centrifuge at 10,000 x g for 20 minutes at 4°C to pellet the **kefir**.
- Re-dissolve the pellet in hot ultrapure water (60°C) and repeat the ethanol precipitation (steps 6-8) for further purification.
- Lyophilize the final pellet to obtain purified **kefir** powder.

Protocol 2: Fabrication of Kefiran Scaffolds by Cryogelation

This protocol is based on the freeze-gelation technique.[7]

Materials:

- Purified **kefir**
- Ultrapure water
- Molds (e.g., 96-well plate)
- -20°C freezer
- 4°C refrigerator
- Freeze-dryer

Procedure:

- Prepare a 2% (w/v) solution of **kefiran** in ultrapure water.
- Dispense the solution into molds.
- Freeze the molds at -20°C for 24 hours.
- Transfer the molds to 4°C for an additional 24 hours to allow for slow thawing and gelation.
- Freeze-dry the resulting cryogels to remove the water and create a porous scaffold.

Protocol 3: Fabrication of Composite Nanofibrous Scaffolds by Electrospinning

This protocol describes the fabrication of a composite scaffold, for example, with Polyacrylonitrile (PAN).[5]

Materials:

- Purified **kefiran**
- Polyacrylonitrile (PAN)
- Distilled water
- Electrospinning apparatus

Procedure:

- Prepare a solution of PAN in a suitable solvent.
- Prepare a separate aqueous solution of **kefiran** (e.g., 5% or 10% w/v).
- Blend the PAN and **kefiran** solutions at the desired ratio.
- Load the blended solution into a syringe fitted with a needle.
- Set up the electrospinning apparatus with a collector plate.

- Apply a high voltage (e.g., 15-25 kV) and a controlled flow rate to eject the polymer solution towards the collector.
- Collect the nanofibers on the collector to form a non-woven mat.
- Dry the scaffold under vacuum to remove any residual solvent.

Protocol 4: Cell Viability and Proliferation Assay

This protocol outlines a standard MTT or AlamarBlue® assay to assess the cytocompatibility of the scaffolds.[5][6]

Materials:

- **Kefiran**-based scaffolds
- Cell line of interest (e.g., fibroblasts, stem cells)
- Complete cell culture medium
- MTT or AlamarBlue® reagent
- 96-well culture plates
- Spectrophotometer or plate reader

Procedure:

- Sterilize the **kefiran** scaffolds (e.g., with UV irradiation or ethanol washes).
- Place the sterile scaffolds into the wells of a 96-well plate.
- Seed cells onto the scaffolds at a predetermined density (e.g., 1×10^4 cells/well).
- Culture the cells for desired time points (e.g., 24, 48, 72 hours).
- At each time point, add the MTT or AlamarBlue® reagent to the wells according to the manufacturer's instructions.

- Incubate for the recommended time.
- Measure the absorbance or fluorescence using a plate reader at the appropriate wavelength.
- Calculate cell viability relative to a control (cells on tissue culture plastic).

IV. Signaling Pathways and Experimental Workflows

The following diagrams, created using the DOT language, illustrate key signaling pathways influenced by **kefiran** and a general experimental workflow for scaffold development.

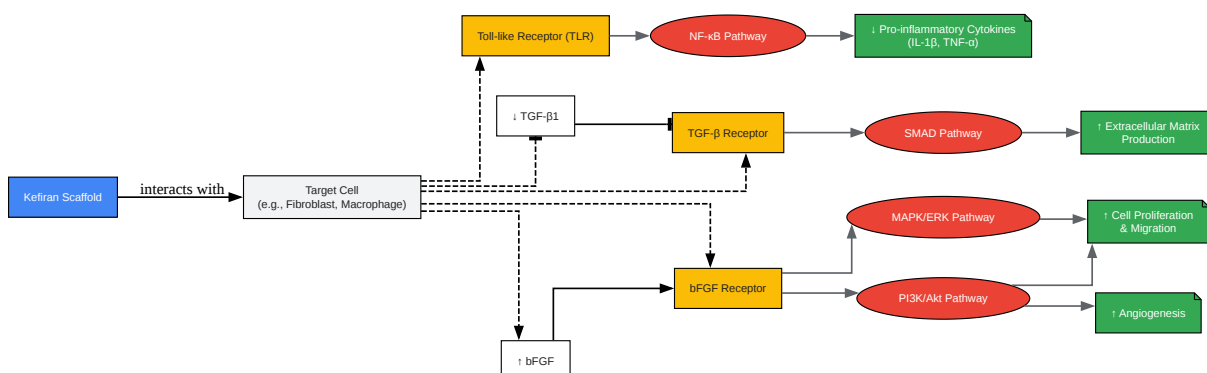

[Click to download full resolution via product page](#)

Caption: **Kefiran's** interaction with cells modulates multiple signaling pathways.

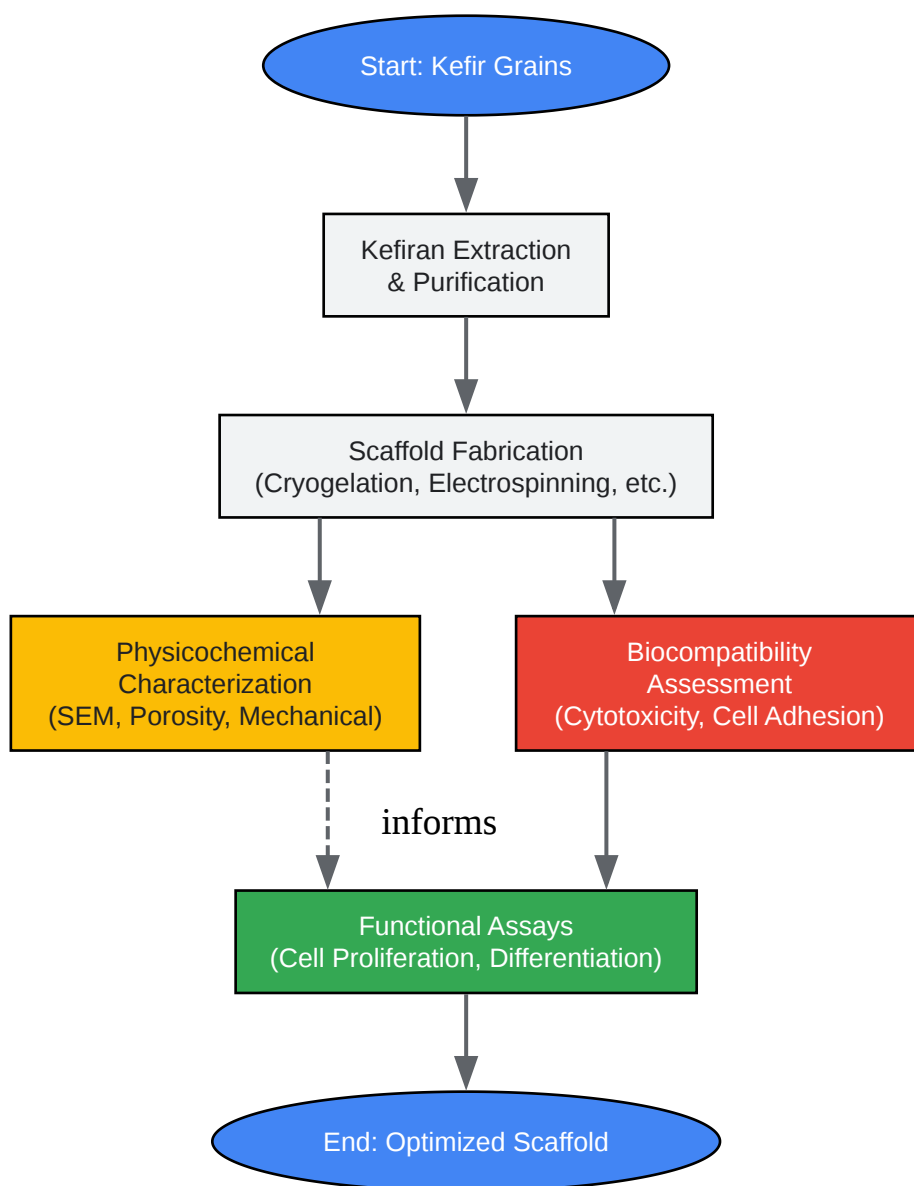

[Click to download full resolution via product page](#)

Need Custom Synthesis?

BenchChem offers custom synthesis for rare earth carbides and specific isotopic labeling.

Email: info@benchchem.com or [Request Quote Online](#).

References

- 1. Lactobacillus kefiranofaciens: From Isolation and Taxonomy to Probiotic Properties and Applications - PMC [[pmc.ncbi.nlm.nih.gov](https://pubmed.ncbi.nlm.nih.gov)]
- 2. researchgate.net [researchgate.net]
- 3. Anti-inflammatory pathways of kefir in murine model: a systematic review - PubMed [pubmed.ncbi.nlm.nih.gov]
- 4. mdpi.com [mdpi.com]
- 5. Kefir Accelerates Burn Wound Healing Through Inducing Fibroblast Cell Migration In Vitro and Modulating the Expression of IL-1 β , TGF- β 1, and bFGF Genes In Vivo - PubMed [pubmed.ncbi.nlm.nih.gov]
- 6. mdpi.com [mdpi.com]
- 7. PI3K/AKT pathway promotes keloid fibroblasts proliferation by enhancing glycolysis under hypoxia - PubMed [pubmed.ncbi.nlm.nih.gov]
- To cite this document: BenchChem. [Application Notes and Protocols for Developing Kefiran-Based Scaffolds in Tissue Engineering]. BenchChem, [2026]. [Online PDF]. Available at: [<https://www.benchchem.com/product/b608327/docs#application-notes-and-protocols-for-developing-kefiran-based-scaffolds-in-tissue-engineering>]

Disclaimer & Data Validity:

The information provided in this document is for Research Use Only (RUO) and is strictly not intended for diagnostic or therapeutic procedures. While BenchChem strives to provide accurate protocols, we make no warranties, express or implied, regarding the fitness of this product for every specific experimental setup.

Technical Support: The protocols provided are for reference purposes. Unsure if this reagent suits your experiment?

Need Industrial/Bulk Grade? [Request Custom Synthesis Quote](#)

BenchChem

Our mission is to be the trusted global source of essential and advanced chemicals, empowering scientists and researchers to drive progress in science and industry.

Contact

Address: 3281 E Guasti Rd

Ontario, CA 91761, United States

Phone: (601) 213-4426

Email: info@benchchem.com

[Contact our Ph.D. Support Team for a compatibility check](#)