

Technical Support Center: Fmoc-PEG3-CH₂CO₂-NHS Chemistry

Author: BenchChem Technical Support Team. **Date:** May 2026

Compound of Interest

Compound Name: *Fmoc-PEG3-CH₂CO₂-NHS*

Cat. No.: *B607512*

[Get Quote](#)

Welcome to the technical support center for **Fmoc-PEG3-CH₂CO₂-NHS** chemistry. This guide is designed for researchers, scientists, and drug development professionals to provide in-depth technical guidance, troubleshooting advice, and answers to frequently asked questions. Our goal is to empower you to navigate the complexities of this versatile linker and achieve successful, reproducible results in your bioconjugation experiments.

Introduction to Fmoc-PEG3-CH₂CO₂-NHS

Fmoc-PEG3-CH₂CO₂-NHS is a heterobifunctional linker that serves as a cornerstone in modern bioconjugation, particularly in the synthesis of antibody-drug conjugates (ADCs) and PROTACs. Its structure is intelligently designed with three key components:

- N-Hydroxysuccinimide (NHS) Ester: A highly reactive group that selectively forms stable amide bonds with primary amines, such as those found on the side chain of lysine residues or the N-terminus of proteins.[1][2]
- Polyethylene Glycol (PEG) Spacer (PEG3): A short, hydrophilic triethylene glycol chain that enhances the solubility and bioavailability of the resulting conjugate while providing a defined spatial separation between the conjugated molecules.[3]

- Fluorenylmethyloxycarbonyl (Fmoc) Group: A base-labile protecting group on a terminal amine, which allows for a second, orthogonal conjugation step after the initial NHS ester reaction.[4] This sequential reaction capability is critical for the construction of complex biomolecules.[2]

This guide will delve into the practical aspects of using this linker, with a focus on identifying and mitigating common side reactions to ensure the integrity of your final conjugate.

Frequently Asked Questions (FAQs)

Q1: What is the primary reaction of **Fmoc-PEG3-CH2CO2-NHS**?

A1: The primary reaction is the acylation of a primary amine by the NHS ester, forming a stable amide bond.[2] This reaction is a nucleophilic acyl substitution where the amine attacks the carbonyl carbon of the NHS ester, releasing N-hydroxysuccinimide as a byproduct.[2]

Q2: What are the optimal pH conditions for the NHS ester reaction?

A2: The optimal pH range for the reaction of an NHS ester with a primary amine is between 7.2 and 8.5.[2] Below pH 7, the amine is largely protonated and non-nucleophilic, slowing or halting the reaction.[2] Above pH 8.5, the rate of hydrolysis of the NHS ester increases significantly, which competes with the desired amine reaction.[2]

Q3: Which buffers should I use for the conjugation reaction?

A3: It is crucial to use a non-nucleophilic buffer to avoid unwanted side reactions with the NHS ester. Recommended buffers include phosphate-buffered saline (PBS), borate buffer, or bicarbonate/carbonate buffer.[5] Avoid buffers containing primary amines, such as Tris (tris(hydroxymethyl)aminomethane) or glycine, as they will compete with your target molecule for reaction with the NHS ester.[5]

Q4: How should I store and handle the **Fmoc-PEG3-CH2CO2-NHS** reagent?

A4: The NHS ester moiety is highly susceptible to hydrolysis from moisture.[5] Therefore, the reagent should be stored at -20°C with a desiccant.[5] Before opening, allow the vial to equilibrate to room temperature to prevent condensation.[5] It is recommended to dissolve the

reagent in an anhydrous solvent like DMSO or high-quality, amine-free DMF immediately before use and not to prepare stock solutions for long-term storage.[5][6]

Q5: What is the purpose of the Fmoc group?

A5: The Fmoc group is a protecting group for a primary amine at the other end of the PEG linker.[4] It remains stable during the NHS ester conjugation. After your molecule of interest is attached via the NHS ester, the Fmoc group can be selectively removed under basic conditions (typically with a solution of piperidine in DMF) to reveal a free amine.[4] This newly exposed amine is then available for a second conjugation reaction.[7]

Reaction Workflow and Mechanisms

The use of **Fmoc-PEG3-CH₂CO₂-NHS** typically follows a two-stage process. The diagram below illustrates the intended reaction pathway and a critical competing side reaction.

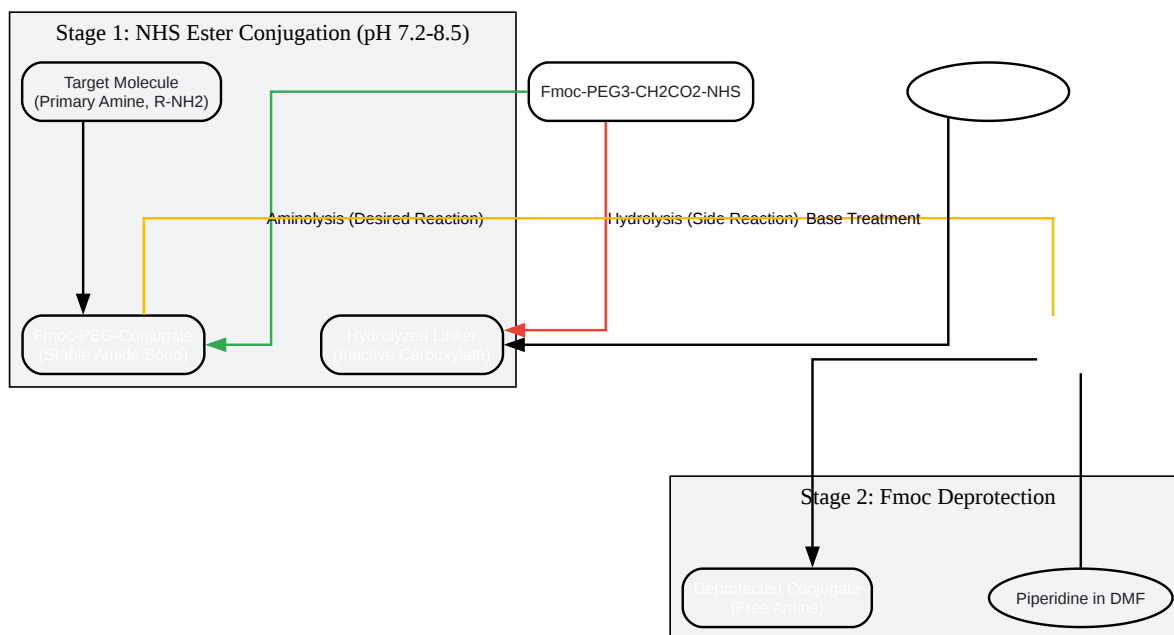

[Click to download full resolution via product page](#)

Caption: Workflow of **Fmoc-PEG3-CH₂CO₂-NHS** conjugation and deprotection.

Troubleshooting Guide

This section addresses common issues encountered during experiments with **Fmoc-PEG3-CH₂CO₂-NHS**. Each problem is presented with potential causes and actionable solutions.

Symptom	Potential Cause	Recommended Solution & Explanation
Low or No Conjugation Efficiency	<p>1. Hydrolysis of the NHS Ester: The CH₂CO₂-NHS (succinimidyl carboxymethyl ester) moiety is highly reactive and has a very short half-life in aqueous solutions, potentially less than five minutes.[4] This is the most common cause of failure.</p>	<p>a. Minimize Time in Aqueous Buffer: Add the dissolved linker to your amine-containing solution immediately after preparation. Do not let the reconstituted reagent sit.[5] b. Optimize pH: Work within the recommended pH range of 7.2-8.5. While the reaction with amines is faster at higher pH, so is hydrolysis. A pH of 7.5-8.0 is often a good compromise.[2] c. Increase Reagent Stoichiometry: Use a molar excess (e.g., 5-20 fold) of the PEG linker to compensate for hydrolysis. The optimal ratio should be determined empirically.</p>
	<p>2. Poor Reagent Quality: The linker may have degraded due to improper storage or may contain impurities from synthesis (e.g., Fmoc-dimers). [8]</p>	<p>a. Proper Storage: Always store the reagent at -20°C with a desiccant.[5] b. Use High-Purity Reagent: Source the linker from a reputable supplier. If in doubt about the quality, consider analytical validation (e.g., HPLC, MS) of a new batch.</p>
	<p>3. Inactive Target Molecule: The primary amines on your target molecule may be inaccessible or protonated.</p>	<p>a. Confirm Amine Availability: Ensure your protein or molecule is correctly folded and that the target amines are solvent-exposed. b. Check Buffer pH: Verify that the</p>

	<p>reaction buffer pH is above 7.2 to ensure the amine is deprotonated and nucleophilic.</p> <p>[2]</p>	
<p>4. Presence of Competing Nucleophiles: Your sample or buffer may contain primary amines (e.g., Tris, glycine, ammonium salts) that compete with the target molecule.[5]</p>	<p>a. Buffer Exchange: Perform a buffer exchange (e.g., dialysis, desalting column) into an amine-free buffer like PBS before starting the conjugation.</p> <p>[5]</p>	
<p>Incomplete Fmoc Deprotection</p>	<p>1. Inefficient Deprotection Reagent: The piperidine solution may be old or of poor quality.</p>	<p>a. Use Fresh Reagent: Prepare a fresh solution of 20% piperidine in high-quality, amine-free DMF for each use.</p> <p>[6]</p>
<p>2. Peptide Aggregation: If conjugating to a peptide, the growing chain may aggregate, hindering access of the piperidine to the Fmoc group.</p>	<p>a. Modify Deprotection Conditions: Increase the deprotection time or perform multiple, shorter deprotection steps.[9]</p>	
<p>Unexpected Side Products</p>	<p>1. Cleavage of the Linker: The ester bond within the CH₂CO₂ part of the linker could potentially be susceptible to cleavage under the basic conditions of Fmoc deprotection, especially with prolonged exposure.</p>	<p>a. Minimize Deprotection Time: Use the shortest effective time for Fmoc removal (e.g., two treatments of 5-7 minutes).[6] Monitor the deprotection by UV spectroscopy if possible.</p>
<p>2. Aspartimide Formation: If your target molecule is a peptide containing an Asp-Xxx sequence, the basic conditions of Fmoc deprotection can catalyze the formation of a cyclic aspartimide, a common</p>	<p>a. Modify Deprotection: Consider using a milder base or a deprotection cocktail containing an additive like 1-hydroxybenzotriazole (HOBt) to suppress this side reaction.</p>	

side reaction in Fmoc-based peptide synthesis.[5][9]

3. Reaction with Other

Nucleophiles: Besides primary amines, the NHS ester can react with other nucleophilic groups like thiols (cysteines) or hydroxyls (serine, threonine), although the resulting thioester and ester linkages are less stable than the amide bond and can be displaced by amines.[1]

a. Control Reaction

Conditions: The reaction with amines is significantly more favorable at the recommended pH. If your molecule has highly reactive thiols, consider protecting them before the NHS ester conjugation.

Experimental Protocols

Protocol 1: Conjugation of Fmoc-PEG3-CH₂CO₂-NHS to a Primary Amine

This protocol provides a general guideline for conjugating the linker to a protein. Molar excess and reaction times may need to be optimized for your specific application.

Materials:

- **Fmoc-PEG3-CH₂CO₂-NHS**
- Protein or molecule with primary amines
- Conjugation Buffer: 0.1 M sodium phosphate, 0.15 M NaCl, pH 7.5 (Amine-free)
- Anhydrous DMSO or DMF
- Quenching Buffer: 1 M Tris-HCl, pH 8.0
- Desalting column for purification

Procedure:

- **Sample Preparation:** Prepare your protein in the Conjugation Buffer. If the protein is in a buffer containing amines, perform a buffer exchange.
- **Reagent Preparation:** Immediately before use, dissolve a calculated amount of **Fmoc-PEG3-CH₂CO₂-NHS** in a small volume of anhydrous DMSO or DMF to create a concentrated stock solution. A 10-20 fold molar excess over the protein is a good starting point.
- **Conjugation Reaction:** Add the dissolved PEG linker solution to the protein solution while gently vortexing.
- **Incubation:** Incubate the reaction for 1-2 hours at room temperature or for 2-4 hours at 4°C. Longer incubation times may be required for less concentrated protein solutions.
- **Quenching (Optional):** To stop the reaction, add the Quenching Buffer to a final concentration of 50-100 mM. Incubate for 15-30 minutes. This will hydrolyze any remaining NHS ester.
- **Purification:** Remove excess, unreacted PEG linker and byproducts using a desalting column or dialysis, exchanging into a suitable buffer for your downstream application.

Protocol 2: Fmoc Group Deprotection

This protocol describes the removal of the Fmoc group from the PEG-conjugated molecule to expose the terminal amine.

Materials:

- Fmoc-PEG-conjugated molecule
- Deprotection Solution: 20% piperidine (v/v) in high-quality, amine-free DMF
- Anhydrous DMF
- Precipitation Solvent: Cold diethyl ether

Procedure:

- **Solvent Exchange:** Ensure your Fmoc-PEG-conjugate is dissolved in anhydrous DMF. If it is in an aqueous buffer, it must be lyophilized first.

- Deprotection Reaction: Add the Deprotection Solution to the dissolved conjugate.
- Incubation: Incubate at room temperature. The reaction is typically fast, often complete within 15-30 minutes. Progress can be monitored by HPLC or by UV spectroscopy for the appearance of the dibenzofulvene-piperidine adduct at ~300 nm.
- Purification:
 - Precipitation: Once the reaction is complete, precipitate the deprotected product by adding the reaction mixture dropwise to a large volume of cold diethyl ether.
 - Centrifugation: Pellet the precipitate by centrifugation.
 - Washing: Wash the pellet several times with cold diethyl ether to remove piperidine and the dibenzofulvene adduct.
 - Drying: Dry the final product under vacuum.

Data Summary Table

The following table summarizes key quantitative parameters for successful experimentation.

Parameter	Recommended Value	Rationale & Notes
NHS Ester Reaction pH	7.2 - 8.5	Balances amine nucleophilicity and NHS ester hydrolysis.[2]
Fmoc Deprotection Reagent	20% Piperidine in DMF	Standard and effective reagent for rapid Fmoc removal.[4]
Reaction Temperature	4°C to Room Temperature	Lower temperatures can help minimize hydrolysis of the NHS ester.[10]
Reaction Time (NHS Ester)	1 - 4 hours	Dependent on temperature and concentration. Should be optimized.
Reaction Time (Fmoc Deprotection)	15 - 30 minutes	Typically a fast reaction. Prolonged exposure can lead to side reactions.
Solvent for Reagent Dissolution	Anhydrous DMSO or DMF	NHS esters are moisture-sensitive.[5] Ensure DMF is amine-free.[6]

References

- Glen Research. (n.d.). Technical Brief - NHS Ester Amine Reaction for Oligonucleotide Labeling. Glen Report 32-26. Retrieved from [[Link](#)]
- Nowick, J. S., et al. (2020). Standard practices for Fmoc-based solid-phase peptide synthesis in the Nowick laboratory (Version 1.7.2). University of California, Irvine.
- BenchChem. (2025). Mechanism of Fmoc-PEG5-NHS ester reaction with primary amines. Retrieved from [<https://www.benchchem.com/product/b15138865#mechanism-of-fmoc-peg5-nhs-ester-reaction-with-primary-amines>]
- Arote, R. B., et al. (2021). Fmoc-Removal with Pyrrolidine Expands the Available Solvent Space in Green Solid-Phase Peptide Synthesis. ACS Sustainable Chemistry & Engineering.
- Wade, J. D., et al. (2000). Base-induced side reactions in Fmoc-solid phase peptide synthesis: Minimization by use of piperazine as N α -deprotection reagent. Letters in Peptide Science.

- AxisPharm. (2024). Protocol for PEG NHS Reagents. Retrieved from [[Link](#)]
- Aapptec. (2019). Fmoc-PEG Linkers and PEGylation Reagents. Retrieved from [[Link](#)]
- Hermanson, G. T. (2020).
- Interchim. (n.d.). 4-Arm branched Pegylation agents > 4Arms-PEG-Succinimidyl esters.
- Majekodunmi, B. O. (2007).
- Comellas, G., et al. (2009).
- AxisPharm. (n.d.). Fmoc PEG, Fmoc Amino PEG Reagent, Fmoc-NH Linkers. Retrieved from [[Link](#)]
- Luna, O., et al. (2016).
- Ferrazzano, L., et al. (2021).
- AxisPharm. (n.d.). Fmoc PEG. Retrieved from [[Link](#)]
- Glyco MindSynth. (n.d.). **Fmoc-PEG3-CH2CO2-NHS**. Retrieved from [[Link](#)]
- JenKem Technology. (n.d.). PEG (Succinimidyl Carboxymethyl Ester)2. Retrieved from [[Link](#)]
- BenchChem. (2025). Application Notes and Protocols: Fmoc-protected Amino-PEG3-CH2COOH in Solid-Phase Peptide Synthesis. Retrieved from [<https://www.benchchem.com/product/b15138865#application-notes-and-protocols-fmoc-protected-amino-peg3-ch2cooh-in-solid-phase-peptide-synthesis>]

Need Custom Synthesis?

BenchChem offers custom synthesis for rare earth carbides and specific isotopic labeling.

Email: info@benchchem.com or [Request Quote Online](#).

Sources

- 1. [luxembourg-bio.com](https://www.luxembourg-bio.com) [[luxembourg-bio.com](https://www.luxembourg-bio.com)]
- 2. pdf.benchchem.com [pdf.benchchem.com]
- 3. pdf.benchchem.com [pdf.benchchem.com]
- 4. [creativepegworks.com](https://www.creativepegworks.com) [[creativepegworks.com](https://www.creativepegworks.com)]

- [5. Deprotection Reagents in Fmoc Solid Phase Peptide Synthesis: Moving Away from Piperidine? - PMC \[pmc.ncbi.nlm.nih.gov\]](#)
- [6. chem.uci.edu \[chem.uci.edu\]](#)
- [7. Fmoc-PEG3-CH2CO2-NHS - CD Bioparticles \[cd-bioparticles.net\]](#)
- [8. chempep.com \[chempep.com\]](#)
- [9. chempep.com \[chempep.com\]](#)
- [10. interchim.fr \[interchim.fr\]](#)
- To cite this document: BenchChem. [Technical Support Center: Fmoc-PEG3-CH2CO2-NHS Chemistry]. BenchChem, [2026]. [Online PDF]. Available at: [\[https://www.benchchem.com/product/b607512/docs#technical-support-center-fmoc-peg3-ch2co2-nhs-chemistry\]](https://www.benchchem.com/product/b607512/docs#technical-support-center-fmoc-peg3-ch2co2-nhs-chemistry)

Disclaimer & Data Validity:

The information provided in this document is for Research Use Only (RUO) and is strictly not intended for diagnostic or therapeutic procedures. While BenchChem strives to provide accurate protocols, we make no warranties, express or implied, regarding the fitness of this product for every specific experimental setup.

Technical Support: The protocols provided are for reference purposes. Unsure if this reagent suits your experiment?

Need Industrial/Bulk Grade? [Request Custom Synthesis Quote](#)

BenchChem

Our mission is to be the trusted global source of essential and advanced chemicals, empowering scientists and researchers to drive progress in science and industry.

Contact

Address: 3281 E Guasti Rd

Ontario, CA 91761, United States

Phone: (601) 213-4426

Email: info@benchchem.com

Contact our Ph.D. Support Team for a compatibility check